



RNJ LOW PROFILE

Harsh Environment Rack & Panel Cylindrical Connectors

Amphenol



RNJ LOW PROFILE

INTRODUCTION

Realignment capability

Mechanical device ensures axial (± 1 mm), angular ($\pm 6^\circ$) and longitudinal (0.5 mm) realignments (See figure 1)

Many insert patterns

All available Amphenol Mil-DTL-38999 III inserts

Large contacts range

M39029 contacts compatible with Mil-DTL-38999 III
22D, 20, 16, 12, 8, 4 (contact cavities for signal, coaxial, twinax, power contacts)

EMI shielding

Grounding fingers ensure shielding before contact mating

Low profile and high density

Til 128 size 22D contacts in a 25 shell size

Shell sizes range

8 shell sizes from 11 to 25

Temperature range

- 65°C to 175°C for olive drab cadmium & 200°C for electroless nickel

High durability

500 cycles minimum

High corrosion resistance

Olive drab cadmium (500 hours salt spray) or electroless nickel (48 hours salt spray)

Low tooling investment

Numerous tools common with Mil-DTL-38999 series III connector ones

Light weight

Aluminium alloy shells. For the plug : 20% weight saving versus standard RNJ version

Environmental

Rear membrane protected by a cap on the plug, interfacial seal on male insert

Sealing

Reinforced membrane on the floating plug ensures high pressure resistance (plug withstands 1000mBars on the rear face, 2000mBars on the front face)

Rear accessory possibility

Fully compatible with all M-85049 backshells for Mil-DTL-38999 series III

Contacts protection

100% scoop proof design

Figure 1 - Floating features

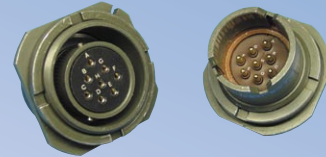
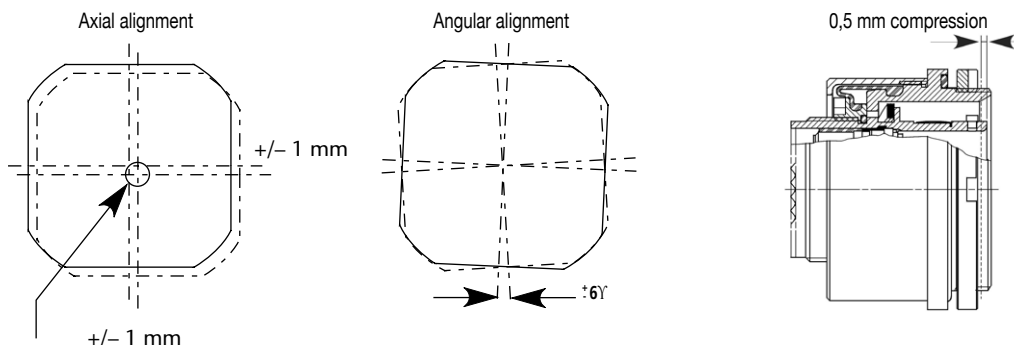

RNJ Low Profile rack and panel connectors are designed to connect electrical devices between a moving unit (rack) and a fixed unit (panel).

The locking of the mating pair is ensured by the mechanical device of the rack.

The RNJLP design allows a short distance between the two panels. This is a big benefit for the systems where space is an issue.

The RNJLP realignment capability (as shown in figure 1) allows to make up the tolerances of the system.

RNJLP are primarily designed for avionic/military and advanced industrial application.

Applications :

- Commercial & military avionic packaging
- Ground / marine / defence applications
- Advanced industrial applications



ENVIRONMENTAL CHARACTERISTICS

Temperature range:

- - 65°C to +175°C (olive drab cadmium) / +200°C (Electroless Nickel)

Air leakage:

- Receptacles RNJLP27/67: less than 16 cm³ / h max @ 2 bars pressure
- Floating plugs RNJLP26 - 66:
 - Front Face: less than 16 cm³ / h max @ 2 bars pressure
 - Rear Face: less than 16 cm³ / h max @ 1 bar pressure

Corrosion resistance:

- Olive drab cadmium 500 h salt spray
- Electroless nickel 48 h salt spray

Fluid resistance:

- MIL-L-7808 (lubricating oil)
- MIL-L-23699 (lubricating oil)
- MIL-H-5606 (hydraulic fluid)
- Hydraulic fluid (Chevron M2V)
- MIL A-8243 (defrosting fluid)
- MIL- C- 87936 type I
- MIL-T-5624 (JP5)
- MIL-C-47220 or Coolanol 25 or equivalent
- MIL-G-3056 type I (gasoline)
- Isopropyl alcohol per TT-I-735 grade A or B mixed with mineral spirit TT-T-291 type I or P-D-680 type I

Two versions available

RNJ Low Profile Square Flange version: RNJLP 66 / 67

- The distance between panels is the same as for the ARINC 404 connector (7,3mm). This allows the user the possibility of replacing an ARINC 404 connectors by an RNJ Low Profile (please consult us regarding dimension tolerances needed for the system).
- More possibilities in shell sizes (8) than with the ARINC 404 (1, 2, 3 or 4 bays only).
- This is front panel mounting for the receptacle and back panel mounting for the floating plug.
- Sealing is provided on the square flange (receptacle and floating plug) by an O-ring gasket (delivered with the connector) located in a groove.

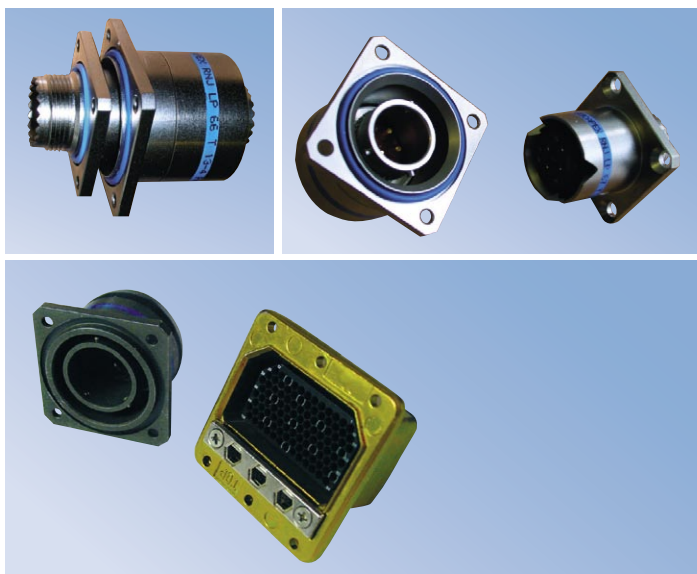

RNJ Low Profile Jam Nut version: RNJLP 26 / 27

- The distance between panels is 16mm versus 36mm for the standard RNJ
- Both receptacle and floating plug are back panel mounting
- Sealing is provided by the O-ring gaskets located in the groove of the front face of the flange (receptacle and floating plug)
- The castle nut of the floating plug is available with 4 holes for lock-wiring capability (optional)
- Each RNJLP26/27 connector is supplied with a stainless steel pin for insertion by force into the chassis

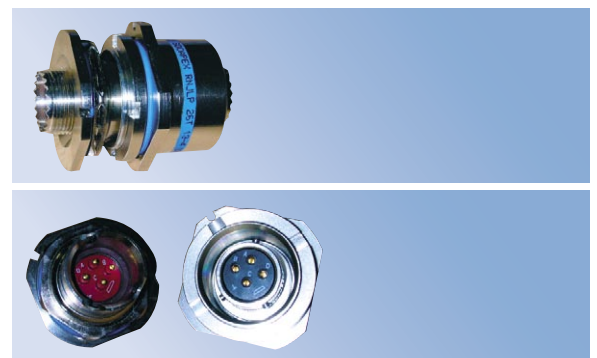

RNJ LOW PROFILE

MECHANICAL CHARACTERISTICS

Contact size	22D	20	16	12	8	4
Maximum load (N)	45	67	110	110	150	150

Mating and unmating forces:

Shell size	Maximum mated force		Maximum unmated force	
	daN	Lbs	daN	Lbs
11	20	45	12	27
13	30	67.4	13	29.2
15	35	78.7	15	33.7
17	50	112.4	16	36
19	55	123.6	18	40.5
21	65	146.1	22	49.5
23	80	179.8	27	60.7
25	102	229.3	34	76.4

Durability: 500 cycles

ELECTRICAL CHARACTERISTICS

Contact rating - nominal current per contact:

Contact size	22D	20	16	12	8*	4*
Current (A)	5	7.5	13	23	60	100

* Please consult us for additional informations regarding power inserts

Contact resistance:

Contact size	22D	20	16	12	8	4
Resistance (mΩ)	8	4.7	2	1.1	0.6	0.26

Insulation resistance: - at ambient > 10⁵ Mohms
- at maximum temperature > 10³ Mohms

Service rating:

Service (p. 4/5)	Dielectric withstanding voltage (Vrms)								Working voltage	
	At sea level		15000 meters		21000 meters		34000 meters			
	mated	unmated	mated	unmated	mated	unmated	mated	unmated	Vrms	Vdc
M	1300	1300	800	550	800	350	800	200	400	550
I	1800	1800	1000	600	1000	400	1000	200	600	850
II	2300	2300	1000	800	1000	500	1000	200	900	1250

Dimensions of acceptable contacts and cables:

Contact size	Contact Diameter mm (in)	Crimp barrel		Acceptable cables								
		Diameter mm (in)	Depth mm (in)	Gauge AWG Section mm ² (sq in)				Outside diameter mm (in)				
				22	24	26	28	min	average	Max		
22D	0.76 (0.030)	0.88±0.03 (0.035±0.001)	3.58 (0.141)	0.38 (0.015)	0.22 (0.009)	0.15 (0.006)	0.095 (0.004)	0.76 (0.03)	1.20 (0.047)	1.37 (0.054)		
20	1 (0.039)	1.19±0.03 (0.039±0.001)	5.30 (0.209)	0.60 (0.024)	0.38 (0.015)	0.22 (0.009)		1.02 (0.04)	1.83 (0.072)	2.11 (0.083)		
16	1.57 (0.062)	1.70±0.03 (0.067±0.001)	5.30 (0.209)	1.6 (0.053)	1.8 (0.037)	2.0 (0.024)		1.68 (0.066)	2.41 (0.095)	2.77 (0.109)		
12	2.36 (0.093)	2.54±0.06 (0.100±0.002)	10 (0.394)	3.30 (0.13)	1.94 (0.076)			2.46 (0.097)	3.20 (0.126)	3.61 (0.142)		
8	3.60 (0.039)	4.6 +0.05 (0.181+0.002)-0	10 (0.394)	8 Min: 8.98 - Max: 10 (Min: 0.354 - Max: 0.394)				4.50 (0.177)	—	5.8 (0.228)		
4	5.75 (0.226)	7.4±0.05 (0.291±0.002)	12 (0.4724)	21.10 (0.831)				7.73 (0.304)	8.08 (0.318)	8.43 (0.332)		

RNJ LOW PROFILE



INSERT ARRANGEMENTS

Contact size	22D	20	16	12	8	4
Caption						

Front view of male insert

Only the major keyway is illustrated.

- ❶ MIL-DTL-38999 Series III insert arrangement reference
- ❷ RNJLP insert arrangement

- ❸ Service class
- ❹ Number of contacts
- ❺ Contact sizes

11

❶	B2		B5		B-35		
❷	11-01	11-2	11-4	11-5	11-12	11-35	11-98
❸	I	I	I	I	M	I	I
❹	1	2	4	5	1	13	7
❺	8	16	20	20	12	22D	20

Twinax^A

13

❶	C 4	C 8	13-26	C 35
❷	13-4	13-8	13-35	13-98
❸	I	I	M	M
❹	4	8	6 2	22
❺	16	20	22D 12	22D

15

❶	D 05	D 15	D 18	D 19	D 35
❷	15-5	15-15	15-18	15-19	15-35
❸	M	I	I	I	M
❹	5	14 1	18	19	37
❺	16	20 16	20	20	22D

17

❶	E 6	E 8	17-20	17-22	E 26	E 35	17-75	E 99
❷	17-2	17-6	17-8	17-20	17-22	17-26	17-35	17-99
❸	M	I	II	M	I	I	M	I
❹	38 1	6	8	16 4	2 2	26	55	21 2
❺	22D 8 Twinax ^o	12	16	22D 12	12 8	20	22D	20 16

Coax Twinax^A Twinax^o

RNJ LOW PROFILE

INSERT ARRANGEMENTS

Contact size	22D	20	16	12	8	4
Caption						

Front view of male insert
Only the major keyway is illustrated.

- ① MIL-DTL-38999 Series III insert arrangement reference
- ② RNJLP insert arrangement

- ③ Service class
- ④ Number of contacts
- ⑤ Contact sizes

19

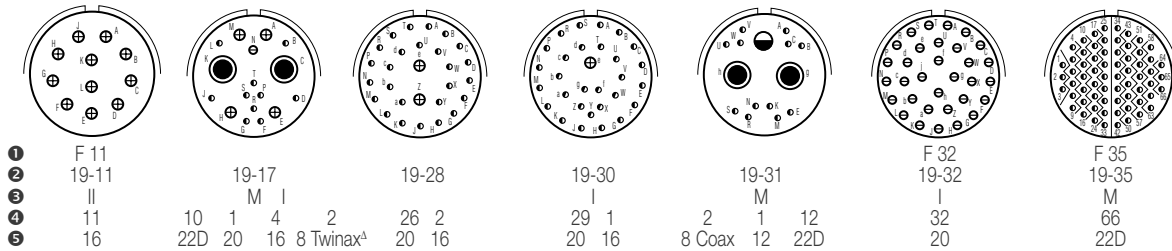

21

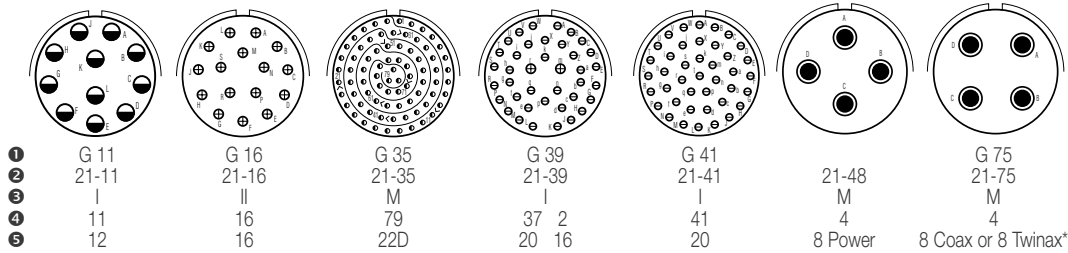

23

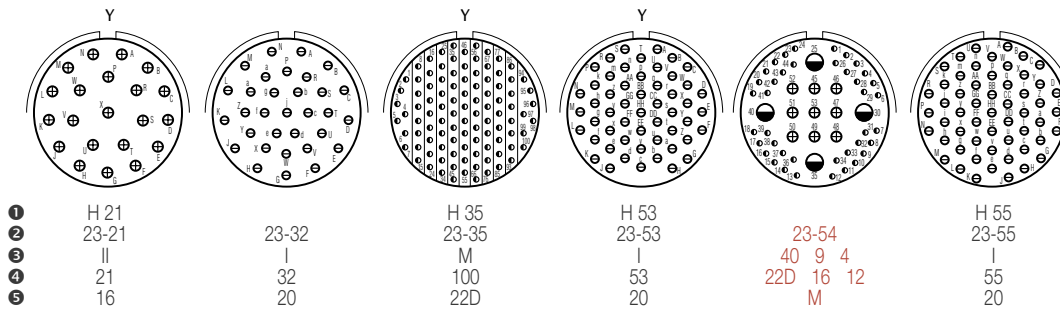

25

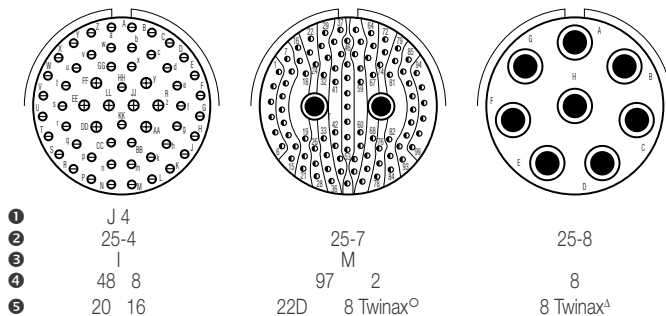

RNJ LOW PROFILE



INSERT ARRANGEMENTS

Contact size	22D	20	16	12	8	4
Caption						

Front view of male insert

Only the major keyway is illustrated.

- ① MIL-DTL-38999 Series III insert arrangement reference
- ② RNJLP insert arrangement

- ③ Service class
- ④ Number of contacts
- ⑤ Contact sizes

25

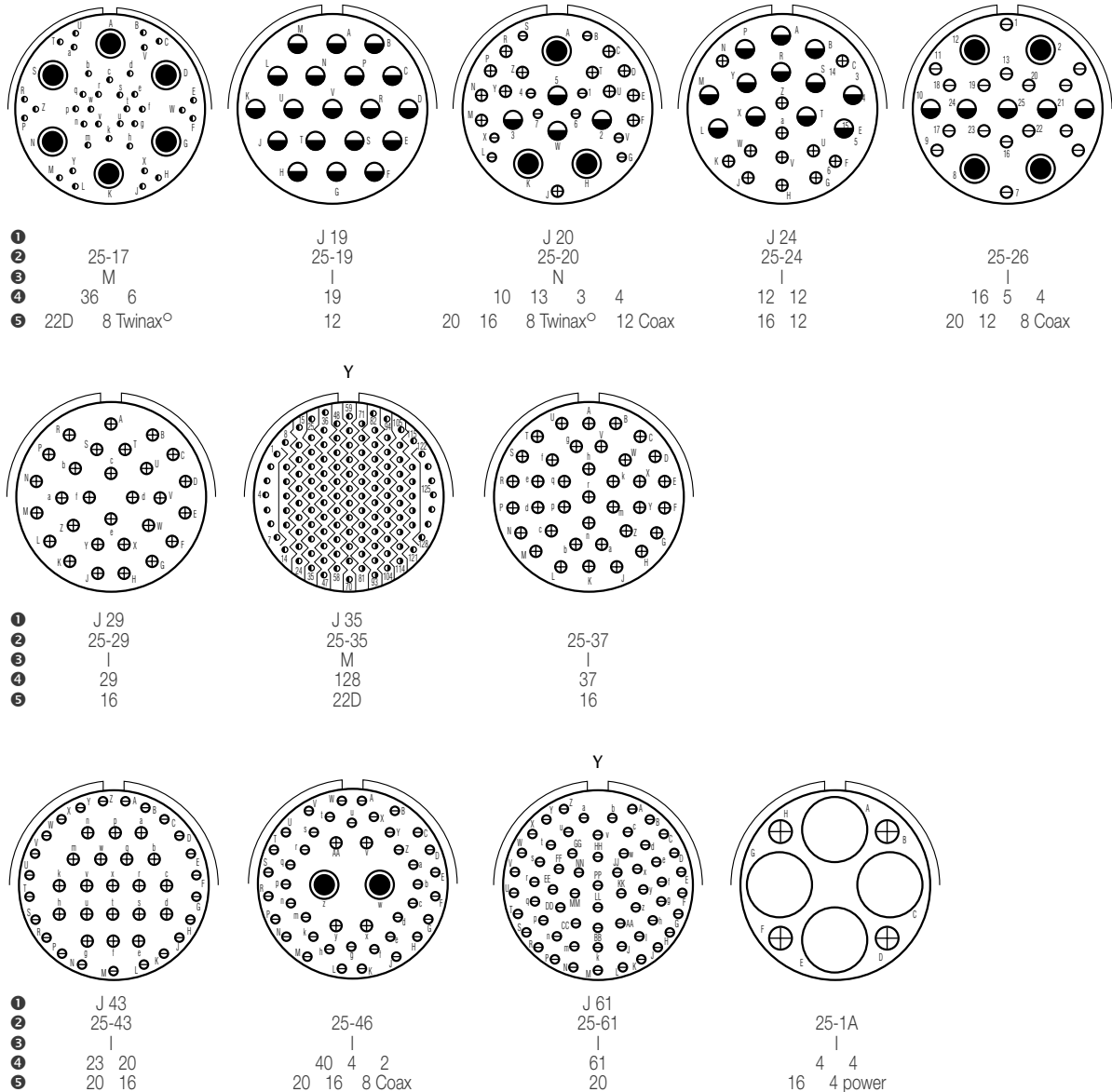

- * P/N delivered with size 8 coaxial contacts for RG 180 and RG 195 wire
- Y Available in hermetic version
- Δ Delivered with twinax contacts for double braid cable (PAN 6421, AECMA Pr EN 3375 - 004, Raychem 10613, EPD44692, EPD44693).
- Delivered with twinax contacts for simple braid cable (M17/1760002, AECMA Pr EN 3375 - 003, Raychem 10612, EPD44690, EPD44691).

Only most commonly used inserts arrangements are listed here. All other Amphenol inserts are available, please call us for details.

RNJ LOW PROFILE

Arrangements	Service Class	Total number of contacts	Number and size of contacts									Grounded Insert availability**	
			22D	20	16	12	12 coax	8 power	8 coax	8 triax or twinax	4	P	S
11-1		1									1		
11-2**		2										X	
11-2	I	2			2								
11-4	I	4		4									
11-5	I	5		5									
11-12	II	1				1							
11-35	M	13	13										
11-98	I	6		6									
11-99	I	7		7									
13-4**		4										X	
13-4	I	4			4								
13-8	I	8		8									
13-26	M	8	6				2						
13-35	M	22	22										
13-98	I	10		10									
15-5**		5										X	
15-5	II	5			5								
15-15	I	15		14	1								
15-18	I	18		18									
15-19	I	19		19									
15-35	M	37	37										
15-97	I	12		8	4								
17-2	M	39	38							1			
17-6**		6										X	
17-6	I	6				6							
17-8**		8										X	X
17-8	II	8			8								
17-22**		4										X	
17-26	I	26		26									
17-35	M	55	55										
17-75	I	2								2			
17-99	I	23		21	2								
19-11	II	11			11								
19-17	M	17	10	1	4					2			
19-28	I	28		26	2								
19-30	I	30		29	1								
19-31	M	15	12			1							
19-32	I	32		32									
19-35	M	66	66										
21-11	I	11				11							
21-16**		16										X	
21-16	II	16			16								
21-35	M	79	79										
21-39	I	39		37	2								
21-41	I	41		41									
21-48	M	4						4					
21-75	M	4							4				
21-75**		4										X	

Legend: ** Grounded version (metallic insert for use with coaxial or twinax contacts, for receptacle only), supplied without contact.

RNJ LOW PROFILE



Arrangements	Service Class	Total number of contacts	Number and size of contacts									Grounded Insert availability**	
			22D	20	16	12	12 coax	8 power	8 coax	8 triax or twinax	4	P	S
23-21	II	21			21								
23-21**	II	21											X
23-32	I	32		32									
23-35	M	100	100										
23-53	I	53		53									
23-54	M	53	40		9	4							
23-55	I	55		55									
25-4	I	56		48	8								
25-7	M	99	97							2			
25-8	M	8								8			
25-8**	M	8											X
25-17	M	42	36							6			
25-19	I	19				19							
25-19**	I	19										X	
25-20	N	30		10	13		4*			3			
25-24	I	24			12	12							
25-26	I	25		16		5			4				
25-29**	I	29										X	
25-29	I	29			29								
25-35	M	128	128										
25-37	I	37			37								
25-41	I	41	22	3	11		2*			3			
25-43	I	43		23	20								
25-46	I	46		40	4				2				
25-61	I	61		61									
25-1A	I	8			4						4		

Legend: ** Grounded version (metallic insert for use with coaxial or twinax contacts, for receptacle only), supplied without contact.

Only most commonly used inserts arrangements are listed here. All other Amphenol inserts are available, please call us for details.

RNJ LOW PROFILE

RNJ LOW PROFILE PLUG & RECEPTACLE

Jam Nut version

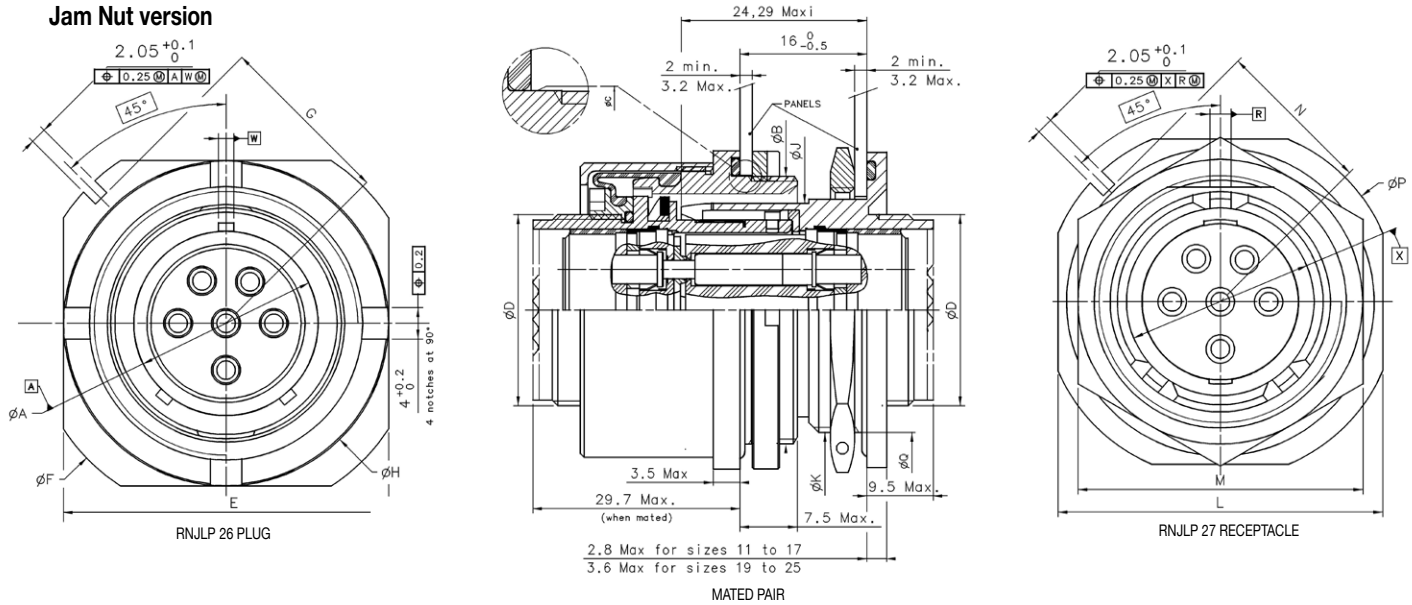

Size	$\phi A_{-0.13}^0$	Thread ϕB	$\phi C_{-0.05}^0$	Thread ϕD	$E_{-0.25}^0$	$\phi F_{-0.4}^0$	$G_{-0.25}^0$	$\phi H_{Max.}$	$\phi J_{Max.}$	Thread ϕK	$L_{-0.4}^0$	$M_{Max.}$	$N_{-0.2}^0$	$\phi P_{-0.4}^0$	$\phi Q_{-0.05}^0$
11	14.38	M25x1-6g R0.100	25.53	M15x1-6g R0.100	32.16	38.50	16.92	32.10	18.68	M20x1-6g R0.100	32.16	25.84	15.33	35.34	20.83
13	17.23	M28x1-6g R0.100	28.75	M18x1-6g R0.100	35.34	41.68	18.51	35.10	21.88	M25x1-6g R0.100	35.34	30.62	16.92	38.51	25.53
15	20.40	M32x1-6g R0.100	31.93	M22x1-6g R0.100	38.51	44.85	20.10	39.10	25.08	M28x1-6g R0.100	38.51	33.76	18.51	41.69	28.75
17	23.58	M35x1-6g R0.100	35.10	M25x1-6g R0.100	41.69	49.63	22.67	42.10	28.18	M32x1-6g R0.100	41.69	36.97	20.10	44.86	31.93
19	26.24	M38x1-6g R0.100	38.23	M28x1-6g R0.100	46.43	52.78	24.26	45.70	31.18	M35x1-6g R0.100	46.43	40.11	22.67	49.64	35.10
21	29.42	M41x1-6g R0.100	41.45	M31x1-6g R0.100	49.64	55.99	25.84	48.70	34.38	M38x1-6g R0.100	49.64	43.32	24.26	52.78	38.23
23	32.59	M44x1-6g R0.100	44.63	M34x1-6g R0.100	52.78	59.13	27.43	51.70	37.58	M41x1-6g R0.100	52.78	46.46	25.84	55.99	41.45
25	35.77	M48x1-6g R0.100	48.03	M37x1-6g R0.100	55.93	59.53	27.58	55.70	40.78	M44x1-6g R0.100	55.99	51.24	27.43	59.13	44.63

Fixing nuts with 4 slots for Jam Nut plug are available with 4 holes for lockwiring capability (optional).

Square Flange version

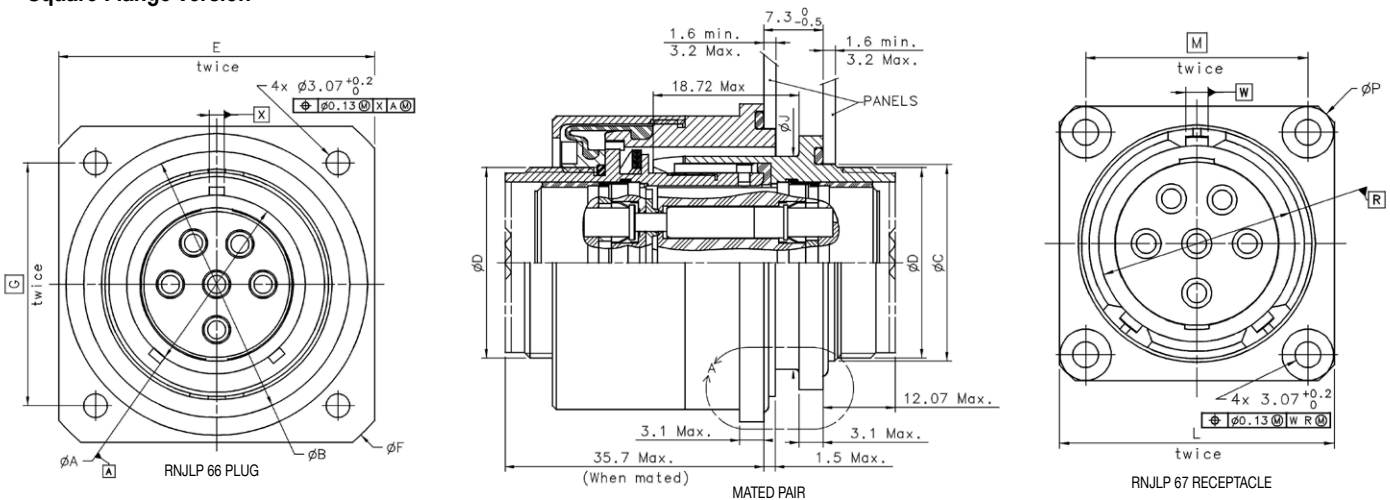

Size	$\phi A_{-0.13}^0$	$\phi B_{-0.05}^0$	$\phi C_{-0.05}^0$	Thread ϕD	$E_{-0.25}^0$	$\phi F_{-0.4}^0$	G	$\phi J_{Max.}$	$L_{-0.3}^0$	M	$\phi P_{-0.4}^0$
11	14.38	25.53	16.73	M15x1-6g R0.100	33.60	45	25.5	18.68	28.3	20.62	37.03
13	17.23	28.75	19.93	M18x1-6g R0.100	36.30	48	28	21.88	30.7	23.01	40.33
15	20.40	31.93	22.83	M22x1-6g R0.100	39.50	52	30	25.08	32.3	24.61	42.63
17	23.58	35.10	25.83	M25x1-6g R0.100	41.69	55	32	28.18	34.7	26.97	45.93
19	26.24	38.23	29.03	M28x1-6g R0.100	46.43	58	35	31.18	37.1	29.36	49.33
21	29.42	41.45	32.23	M31x1-6g R0.100	49.64	60	37	34.38	39.7	31.75	52.73
23	32.59	44.63	34.03	M34x1-6g R0.100	53.00	63	39.5	37.58	42.9	34.93	57.23
25	35.77	48.03	37.23	M37x1-6g R0.100	54.50	65	41.5	40.78	46	38.10	60.03

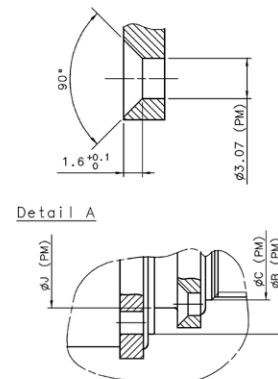

RNJ LOW PROFILE

PANEL DRILLING & RECOMMENDED TORQUE VALUES

Jam Nut version (RNJ LP 26 and 27)

PLUG SIZE	K (min)	W	$\phi X \text{ } ^{+0.1}$
11	32.57	12.81	25.58
13	36	13.94	28.80
15	39.6	15.06	31.98
17	43.3	16.88	35.15
19	47	18	38.28
21	50.6	19.12	41.50
23	54.2	20.24	44.68
25	59.7	20.30	48.08

RECEPTACLE SIZE	K (min)	W	$\phi X \text{ } ^{+0.1}$
11	32.57	11.69	20.86
13	36	12.81	25.58
15	39.6	13.94	28.80
17	43.3	15.06	31.98
19	47	16.88	35.15
21	50.6	18	38.28
23	54.2	19.12	41.50
25	59.7	20.24	44.68

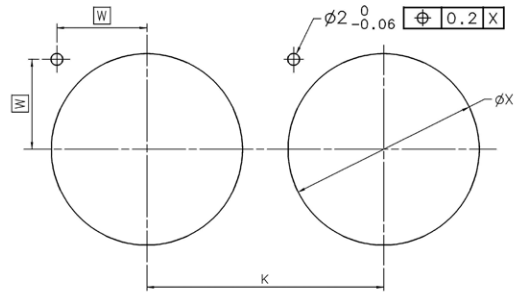

Square Flange version (RNJ LP 66 and 67)

PLUG SIZE	K (min)	W	$\phi X \text{ } ^{+0.1}$
11	36	25.5	25.58
13	39.6	28	28.80
15	43.3	30	31.98
17	47	32	35.15
19	50.6	35	38.28
21	54.2	37	41.50
23	59.7	39.5	44.68
25	59.7	41.5	48.08

RECEPTACLE SIZE	K (min)	W	$\phi X \text{ } ^{+0.1}$
11	36	20.62	16.78
13	39.6	23.01	19.98
15	43.3	24.61	22.88
17	47	26.97	25.88
19	50.6	29.36	29.08
21	54.2	31.75	32.28
23	59.7	34.93	34.08
25	59.7	38.1	37.28

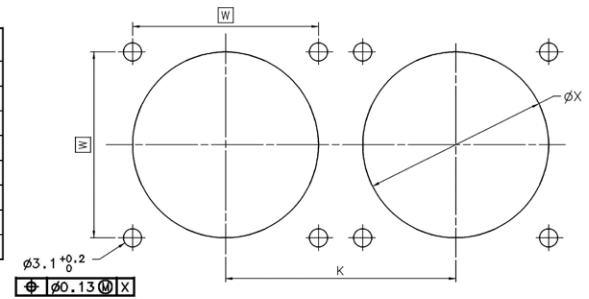

Rear accessories torque values

The following values must be observed. Before applying this coupling torque, locking glue has to be applied on the rear thread of the connector.

Shell size	11	13	15	17	19	21	23	25
Coupling torque (Nm)	8 ± 0.4	11 ± 0.5	11 ± 0.5	14 ± 0.7	14 ± 0.7	17 ± 0.8	17 ± 0.8	20 ± 1
(lb.inch)	0.9 ± 0.05	1.24 ± 0.06	1.24 ± 0.06	1.58 ± 0.08	1.58 ± 0.08	1.92 ± 0.09	1.92 ± 0.09	2.28 ± 0.11

Power contacts with PCB tails

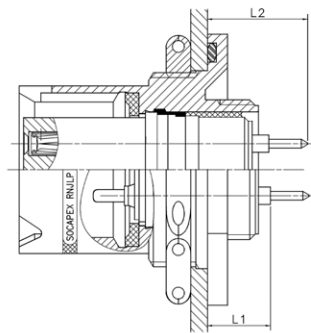

P	L1	min	RNJ LP 27 CI	RNJ LP 27 LI
			mm (in)	mm (in)
S	L1	min	7.89 (.311)	7.89 (.311)
		max	8.57 (.337)	8.57 (.337)
	L2	min	12.79 (.504)	16.29 (.641)
		max	13.67 (.538)	17.17 (.676)

Remark:

the design of the RNJLP27 shell is modified when delivered with PCB contacts (shorter design without serrations)
Other dimensions available upon request: coax, twinax...
For other shell configurations (RNJ LP 67/46/86) equipped with PCB contacts (specific applications), please consult us.

Stand-Off for PCB



New:
RNJ LP 27 receptacles for PCB applications are available with stand-off with holes for M3 screws for fixation on the board.

Example of panel drilling

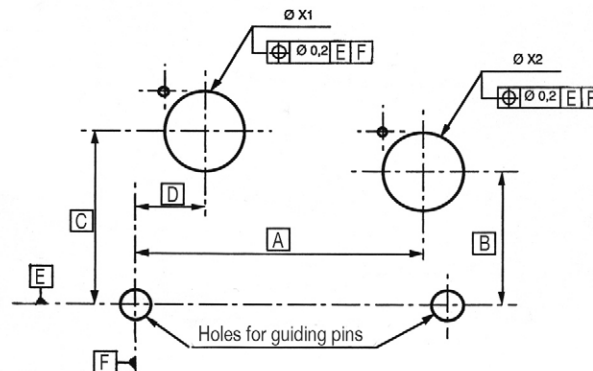

Note:

All the dimensions are referenced from the guiding pin (E, F). The reference axis E goes through the 2 guiding pins centers.



HOW TO ORDER

Series	RNJ LP	26	T	11	35	P	N	014	LC	-
Shell type										
26 - Jam nut plug										
27 - Jam nut receptacle										
66 - Square flange plug										
67 - Square flange receptacle										
46 - Jam Nut plug without rear accessory possibility To be used with PCB TAIL contacts										
86 - Square Flange plug without rear accessory possibility To be used with PCB TAIL contacts only *										
Service class and contact type										
T - Environmental, crimp contacts #22D/20/16/12/4										
CI - Environmental, PCB contacts, standard tails (RNJLP27 only)										
LI - Environmental, PCB contacts, long tails (RNJLP27 only)										
K - Stainless steel version (316 L), crimp contacts										
KCI - Stainless steel version (316 L), PCB contacts, standard tails										
KLI - Stainless steel version (316 L), PCB contacts, long tails										
Shell size										
11/13/15/17/19/21/23/25										
Inserts arrangements										
See pages 5 to 9										
Contact type										
P - Pin contact										
S - Socket contact										
Polarization										
N - Normal position only										
Shell finish										
014 - Olive drab cadmium										
023 - Electroless nickel										
Blank for stainless style version «K»										
Contact										
Blank - Connector supplied with contacts										
LC - Connector supplied without contact («LC» not marked on the connector)										
Deviation										
F404 - Contacts with tin plated PC tails (CI or LI version only)										

For other deviations (FXXX), please consult us.
* Consult us for characteristic dimensions.

Specific requirements:

- 1) For grounded insert part-numbering, please consult us.
- 2) For grounded insert or non-grounded insert compatible with quadax or differential twinax contacts (polarized size 8 cavities), please consult us.
- 3) For inserts to be fitted with RJ45 connectors (RJ Stop Patented), please consult us.

- 4) For jam nut versions (RNJ LP 26 and 27) to be mated with square flange versions (RNJ LP 66 and 67), please consult us for compatibility.
- 5) Differential pressure application: in addition to hermetic receptacle (Pin only) versions with inserts (Pin or socket) compounded with either epoxy resin or RTV160/RTV142 are available upon request. Please call for details.
- 6) A complete RNJ LP Installation User Guide Line is available upon request. (Location of the guiding pin of the system compared to the connectors...)

Box for spanner (for RNJ LP 26 plug installation)



For # 11: RNJ8982A11	For # 19: RNJ8982E19
For # 13: RNJ8982B13	For # 21: RNJ8982F21
For # 15: RNJ8982C15	For # 23: RNJ8982G23
For # 17: RNJ8982D17	For # 25: RNJ8982H25

Amphenol
Socapex

The information given in this document are as a guideline only.
We reserve the right to modify our products in any way we deem necessary.
Any duplication is prohibited, unless approved in writing.
Realisation : wangen:studios - Steven Kilgallon

For more information, please visit our website:
www.amphenol-socapex.com