

REV. A	SHEET 1 OF 2	DOCUMENT NO. TGW-12B09-01SN-255
REVISIONS		
LTR	DESCRIPTION	DATE
A	INITIAL RELEASE	

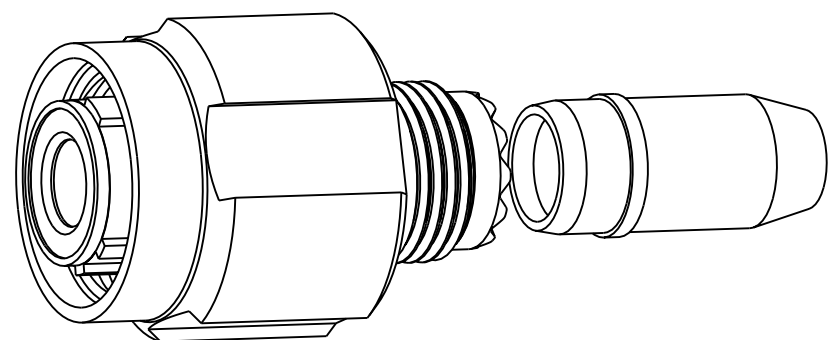

SCALE 2

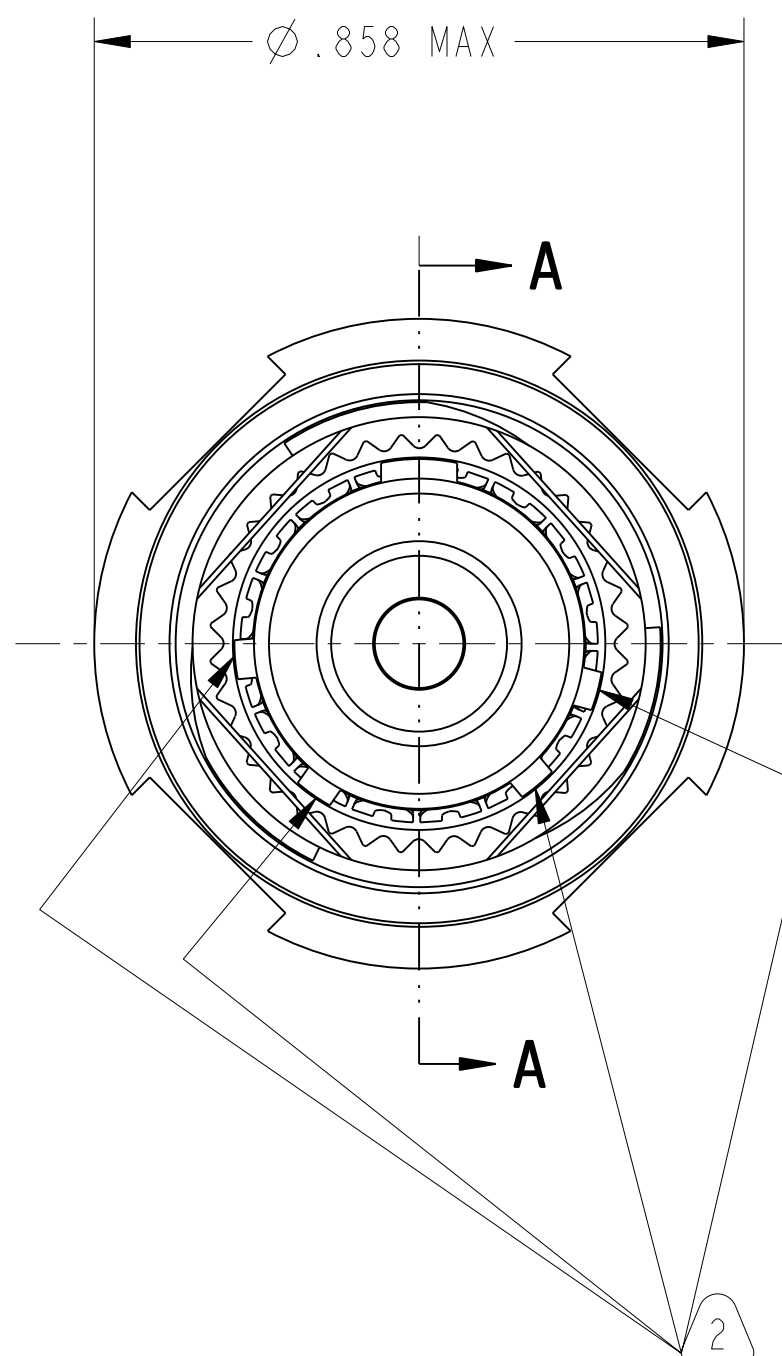
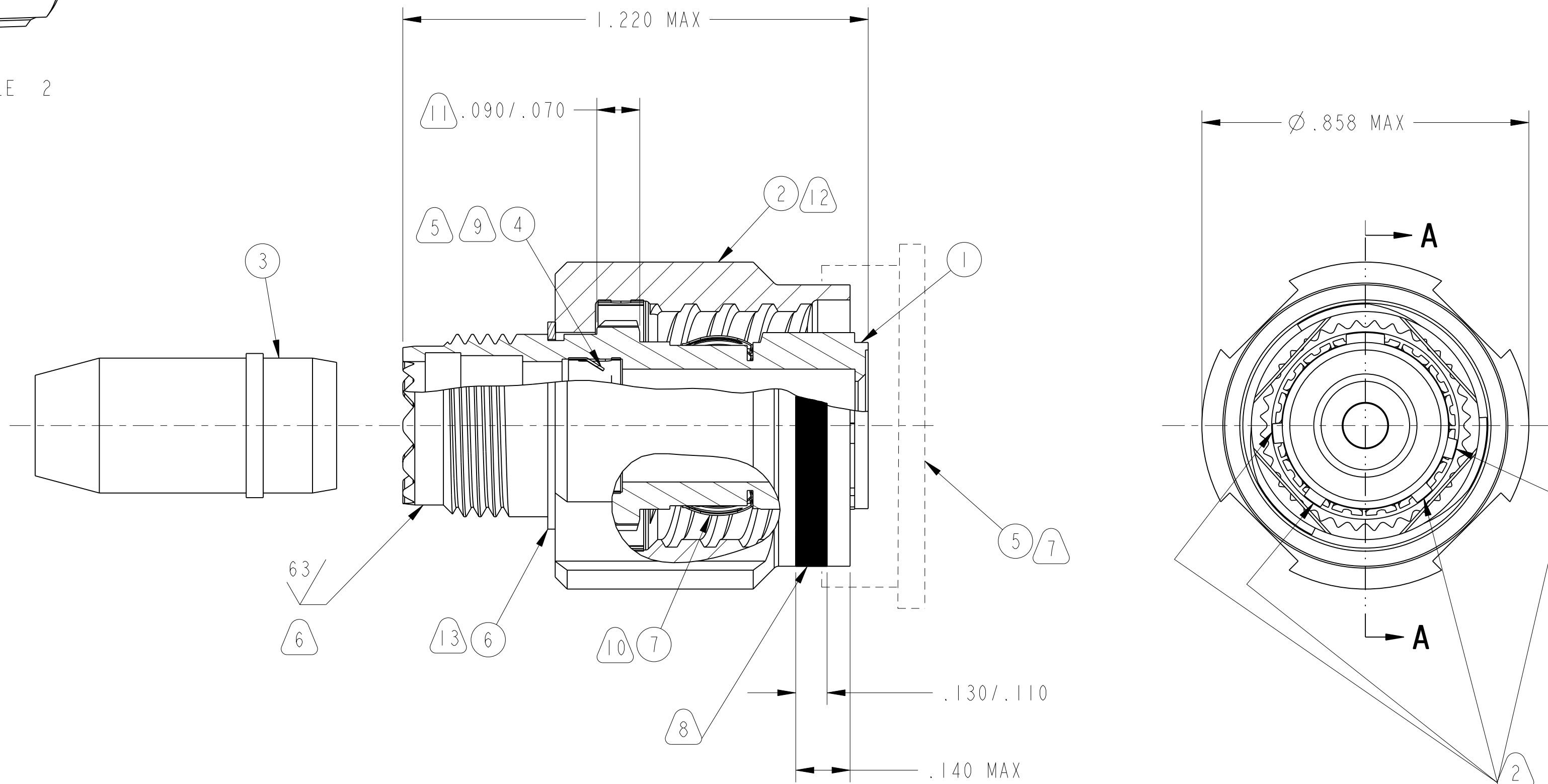

SECTION A-A

POS	QTY	PART NUMBER	DESCRIPTION	NOTE
7	1	T3-8909-16H	SPRING, EMI BAND	
6	1	T3-8109-11E	RETAINING RING	
5	1	10-070500-008	PLASTIC DUST CAP	
4	1	T3-4808-10H	COLLET	
3	1	T3-R-6308-10D	GROMMET BOOT	
2	1	T3-R-7009-13W	COUPLING NUT SUB-ASSEMBLY	
1	1	P-208987-PSXXW	SHELL	4

NOTES: SEE SHEET 2

THE USE OF THIS DOCUMENT IS UNLIMITED. HOWEVER, DOCUMENTS REFERENCED HEREON MAY CONTAIN LIMITED RIGHTS DATA.

RELEASED / Jan . 19 2006, 11:20 AM

N/A	PRO/ENGINEER INFORMATION
N/A	Pro/e Model Used:
	TGW12B0901SA255.ASSEM
	Drawing Name:
	TGW-12B09-01SN-255

UNLESS OTHERWISE SPECIFIED

LINEAR DIMENSIONS ARE IN INCHES  
TOLERANCES:  
.XXXX = ±.0005 ANGLES= ±2°  
.XXX = ±.010  
.XX = ±.03  
.X = ±.1

DIM. & TOL. PER ASME Y14.5M;  
DRM PER MIL-DTL-31000;  
OTHER Amphenol Sds. PER 9-3800

LEGENDS:  
=FLAG NOTE CALL OUT  
REFERENCE ONLY

SPECIFICATIONS

MATERIAL SPEC. N/A

PROCESS SPEC.

SEE NOTES SHEET 2

APPROVALS		DATE
PREPARED BY	D. FREAR	9-Jan-06
ENGINEER IN CHARGE	D. FREAR	
DESIGN MANAGER	E. SHEPLER	
DESIGN ACTIVITY GROUP	MIL-AERO	

THIRD ANGLE PROJECTION

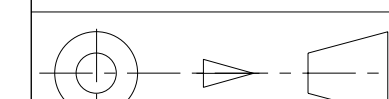

PARTS LIST			
<b>AMPHENOL CORPORATION</b> 40-60 DELAWARE AVENUE SIDNEY, N.Y. 13838			
CONNECTOR, ELECTRICAL PLUG, TYPE TGW-12B09-01(S)-255 LESS CONTACT, SPECIAL PACK			
SIZE <b>C</b>	CAGE CODE <b>77820</b>	DOCUMENT NO. <b>TGW-12B09-01SN-255</b>	REV. <b>A</b>
SCALE: 4.0 REF: P-208987-PSP(X)			SHEET 1 OF 2

TGW-12B09-01SN-255

SHEET 2 OF 2

REV. A

ASSEMBLY PART NUMBER
TGW-12B09-01SN-255
TGW-12B09-01SA-255
TGW-12B09-01SB-255
TGW-12B09-01SC-255
TGW-12B09-01SD-255
TGW-12B09-01SE-255

ALTERNATE SHELL ROTATION

- 11. LUBRICATE ROOT OF SHELL RATCHET TEETH IN AREA WITH SILICONE GREASE PER E4-9.52. GREASE NOT TO EXCEED TEETH DIAMETER.
- 10. ASSEMBLE EMI BAND ITEM(7) ONTO PLUG SHELL PRIOR TO COUPLING NUT ASSEMBLY USING ASSEMBLY SLEEVE. INTIMATE 360° CONTACT TO PLUG BODY TO BE MAINTAINED. LIP EDGE OF EMI BAND MUST BE FIRMLY SEATED INTO GROOVE. TOP LAP EDGES MUST NOT PROTRUDE BEYOND GROOVE SHOULDER. WELD OVERLAP IS TO BE POSITIONED AT MASTER KEY.
- 9. FILL GAP OF COLLET SLOT WITH E4-7.33 EPOXY PER E3-7.94.
- 8. MARK BLUE COLOR BAND IN THIS AREA PER PYLE INK SPEC. E4-9.23.
- 7. APPLY PLASTIC DUST CAP, ITEM 5 TO THE FRONT OF THE CONNECTOR.
- 6. SEALING SURFACE MARKED  $\nabla^{63}$  SHALL NOT BE DAMAGED DURING ASSEMBLY OPERATION.
- 5. SLIDE COLLET, ITEM 4 INTO IT'S LOCKED POSITION IN PLUG SHELL GROOVE WITH APPROPRIATE TOOL.
- 4. SEE PARTS LIST FOR COMPONENT PART NUMBER.
- 3. DRAWING ILLUSTRATES FINAL ASSEMBLY. CONTACTS ARE NOT PART OF THIS ASSEMBLY AND MUST BE PURCHASED SEPARATLY.
- 2. ALTERNATE ROTATIONS ARE OBTAINED BY ROTATING INDICATED KEYWAYS PER EXC-4630. SIX POSITIONS ARE AVAILABLE.
- 1. PACKAGE IN A POLYETHYLENE BAG, THE GROMMET BOOT ITEM 3 SHALL BE SHIPPED UNASSEMBLED. MARK TAG WITH IDENTIFYING NUMBER, DATE CODE AND WORK ORDER NUMBER  
EXAMPLE:  
PYLE TGW-12B09-01PN-255 0549 001000

NOTES:

THE USE OF THIS DOCUMENT IS UNLIMITED. HOWEVER, DOCUMENTS REFERENCED HEREON MAY CONTAIN LIMITED RIGHTS DATA.

RELEASED / Jan . 19 2006, 11:20 AM

TGW - 12 B 09 - 01 S (X)- 255

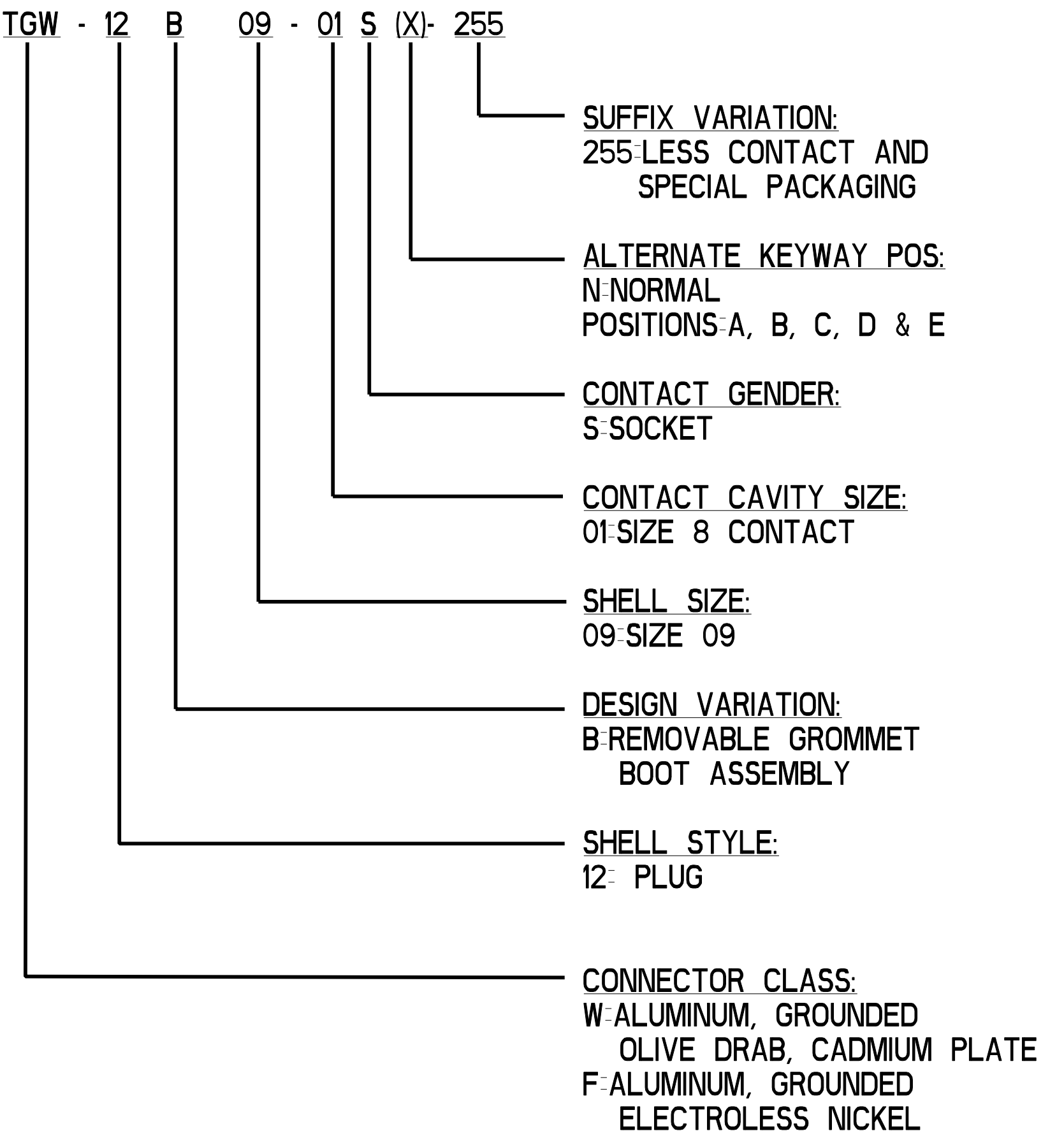

- 14. NO BAKING IS PERMITTED AFTER CONNECTOR HAS BEEN GREASED.
- 13. PLACE RETAINING RING ITEM(6) INTO GROOVE OF PLUG SHELL ITEM (1), BY USING PROPER ASSEMBLY FIXTURE: RETAINING RING MUST BE LUBRICATED WITH LIGHT COAT OF LUBRICANT PER SPEC. E4-8.78 AND CURED PRIOR TO ASSEMBLY.
- 12. ASSEMBLE COUPLING NUT SUB-ASSEMBLY, ITEM(2), ONTO PLUG SHELL ITEM (1) FROM THE REAR END OF PLUG SHELL. MAKE SURE THAT FINGERS OF THE SPRING ARE ON THE PLUG SHELL SHOULDER.

REV. A

SHEET 2 OF 2

TGW-12B09-01SN-255

REV. A

FORMAT: C-U-E-Rev-B

SIZE C	CAGE CODE 77820	DOCUMENT NO. TGW-12B09-01SN-255	REV. A
SCALE: 1.0	REF. P-208987-PSP(X)	SHEET 2 OF 2	