

# PC 6-16/ 3-G1F-10,16 - PCB header



1999013

<https://www.phoenixcontact.com/in/products/1999013>

Please be informed that the data shown in this PDF document is generated from our Online Catalog. Please find the complete data in the user documentation. Our General Terms of Use for Downloads are valid.



PCB headers, nominal cross section: 16 mm<sup>2</sup>, color: green, nominal current: 76 A (41 A in combination with PC 6 plug), rated voltage (III/2): 1000 V, contact surface: Silver, type of contact: Pin, number of potentials: 3, number of rows: 1, number of positions: 3, number of connections: 3, product range: PC 6-16/..-G1F, pitch: 10.16 mm, mounting: Wave soldering, pin layout: Linear pinning, solder pin [P]: 4 mm, number of solder pins per potential: 3, plug-in system: COMBICON PC 16, Pin connector pattern alignment: Standard, locking: Screw locking, mounting: Threaded flange, type of packaging: packed in cardboard

## Your advantages

- Well-known mounting principle allows worldwide use
- Screwable flange for superior mechanical stability
- Maximum flexibility when it comes to device design – one header for connectors with different connection technologies

## Commercial Data

Item number	1999013
Packing unit	50 pc
Minimum order quantity	50 pc
Sales Key	AAE
Product Key	AAESBB
Catalog Page	Page 567 (C-1-2013)
GTIN	4046356038515
Weight per Piece (including packing)	18.422 g
Weight per Piece (excluding packing)	18.422 g
Customs tariff number	85366930
Country of origin	PL

# PC 6-16/ 3-G1F-10,16 - PCB header



1999013

<https://www.phoenixcontact.com/in/products/1999013>

## Technical Data

### Product properties

Type	Headers
Product line	COMBICON Connectors XL
Product type	PCB headers
Product family	PC 6-16/...-G1F
Number of positions	3
Pitch	10.16 mm
Number of connections	3
Number of rows	1
Mounting flange	Threaded flange
Number of potentials	3
Pin layout	Linear pinning
Solder pins per potential	3

### Electrical properties

Nominal current $I_N$	76 A (41 A in combination with PC 6 plug)
Nominal voltage $U_N$	1000 V
Degree of pollution	3
Contact resistance	0.3 m $\Omega$
Rated voltage (III/3)	1000 V
Rated surge voltage (III/3)	8 kV
Rated voltage (III/2)	1000 V
Rated surge voltage (III/2)	8 kV
Rated voltage (II/2)	1000 V
Rated surge voltage (II/2)	6 kV

### Mounting

Mounting type	Wave soldering
Pin layout	Linear pinning

### Flange

Tightening torque	0.3 Nm ... 0.7 Nm
-------------------	-------------------

### Material specifications

#### Material data - contact

Note	WEEE/RoHS-compliant, free of whiskers according to IEC 60068-2-82/JEDEC JESD 201
Contact material	Cu alloy
Surface characteristics	Electroplated silver
Metal surface contact area (top layer)	Silver (4 - 8 $\mu\text{m}$ Ag)
Metal surface contact area (middle layer)	Nickel (2 - 4 $\mu\text{m}$ Ni)
Metal surface soldering area (top layer)	Silver (4 - 8 $\mu\text{m}$ Ag)

# PC 6-16/ 3-G1F-10,16 - PCB header



1999013

<https://www.phoenixcontact.com/in/products/1999013>

Metal surface soldering area (middle layer)	Nickel (2 - 4 µm Ni)
---	----------------------

## Material data - housing

Color (Housing)	green (6021)
Insulating material	PA
Insulating material group	I
CTI according to IEC 60112	600
Flammability rating according to UL 94	V0
Glow wire flammability index GWFI according to EN 60695-2-12	850
Glow wire ignition temperature GWIT according to EN 60695-2-13	775
Temperature for the ball pressure test according to EN 60695-10-2	125 °C

## Material data – actuating element

Color ()	()
----------	----

## Notes

General	In accordance with IEC 61984, COMBICON connectors have no switching power (COC). During designated use, they must not be plugged in or disconnected when carrying voltage or under load.
---------	--

## Dimensions

Dimensional drawing	
Pitch	10.16 mm
Width [w]	48.24 mm
Height [h]	17.4 mm
Length [l]	34 mm
Installed height	13.4 mm
Solder pin length [P]	4 mm

## PCB design

Pin spacing	10.16 mm
-------------	----------

## Mechanical tests

### Test for conductor damage and slackening

Specification	IEC 60999-1:1999-11
Result	Test passed

### Pull-out test

Specification	IEC 60999-1:1999-11
	0.75 mm <sup>2</sup> / solid / > 30 N

# PC 6-16/ 3-G1F-10,16 - PCB header



1999013

<https://www.phoenixcontact.com/in/products/1999013>

Conductor cross section/conductor type/tractive force setpoint/actual value	0.75 mm <sup>2</sup> / flexible / > 30 N
	16 mm <sup>2</sup> / solid / > 100 N
	16 mm <sup>2</sup> / flexible / > 100 N

## Insertion and withdrawal forces

Result	Test passed
No. of cycles	50
Insertion strength per pos. approx.	14 N
Withdraw strength per pos. approx.	12 N

## Torque test

Specification	IEC 60999-1:1999-11
---------------	---------------------

## Contact holder in insert

Specification	IEC 60512-15-1:2008-05
Contact holder in insert Requirements >20 N	Test passed

## Resistance of inscriptions

Specification	IEC 60068-2-70:1995-12
Result	Test passed

## Polarization and coding

Specification	IEC 60512-13-5:2006-02
Result	Test passed

## Visual inspection

Specification	IEC 60512-1-1:2002-02
Result	Test passed

## Dimension check

Specification	IEC 60512-1-2:2002-02
Result	Test passed

## Electrical tests

### Thermal test | Test group C

Specification	IEC 60512-5-1:2002-02
Tested number of positions	8

### Insulation resistance

Specification	IEC 60512-3-1:2002-02
Insulation resistance, neighboring positions	> 5 MΩ

### Air clearances and creepage distances |

Specification	IEC 60664-1:2007-04
Insulating material group	I
Comparative tracking index (IEC 60112)	CTI 600
Rated insulation voltage (III/3)	1000 V

# PC 6-16/ 3-G1F-10,16 - PCB header



1999013

<https://www.phoenixcontact.com/in/products/1999013>

Rated surge voltage (III/3)	8 kV
minimum clearance value - non-homogenous field (III/3)	8 mm
minimum creepage distance (III/3)	12.5 mm
Rated insulation voltage (III/2)	1000 V
Rated surge voltage (III/2)	8 kV
minimum clearance value - non-homogenous field (III/2)	8 mm
minimum creepage distance (III/2)	8 mm
Rated insulation voltage (II/2)	1000 V
Rated surge voltage (II/2)	6 kV
minimum clearance value - non-homogenous field (II/2)	5.5 mm
minimum creepage distance (II/2)	5.5 mm

## Environmental and real-life conditions

### Vibration test

Specification	IEC 60068-2-6:2007-12
Frequency	10 - 150 - 10 Hz
Sweep speed	1 octave/min
Amplitude	0.35 mm (10 Hz ... 60.1 Hz)
Sweep speed	5g (60.1 Hz ... 150 Hz)
Test duration per axis	2.5 h

### Durability test

Specification	IEC 60512-9-1:2010-03
Impulse withstand voltage at sea level	9.8 kV
Contact resistance $R_1$	0.3 m $\Omega$
Contact resistance $R_2$	0.3 m $\Omega$
Insertion/withdrawal cycles	50
Insulation resistance, neighboring positions	> 5 M $\Omega$

### Climatic test

Specification	ISO 6988:1985-02
Corrosive stress	0.2 dm <sup>3</sup> SO <sub>2</sub> on 300 dm <sup>3</sup> /40 °C/1 cycle
Thermal stress	105 °C/168 h
Power-frequency withstand voltage	4.26 kV

### Ambient conditions

Ambient temperature (operation)	-40 °C ... 105 °C (dependent on the derating curve)
Ambient temperature (storage/transport)	-40 °C ... 70 °C
Relative humidity (storage/transport)	30 % ... 70 %
Ambient temperature (assembly)	-5 °C ... 100 °C

## Packaging specifications

Type of packaging	packed in cardboard
-------------------	---------------------

Drawings

Drilling plan/solder pad geometry

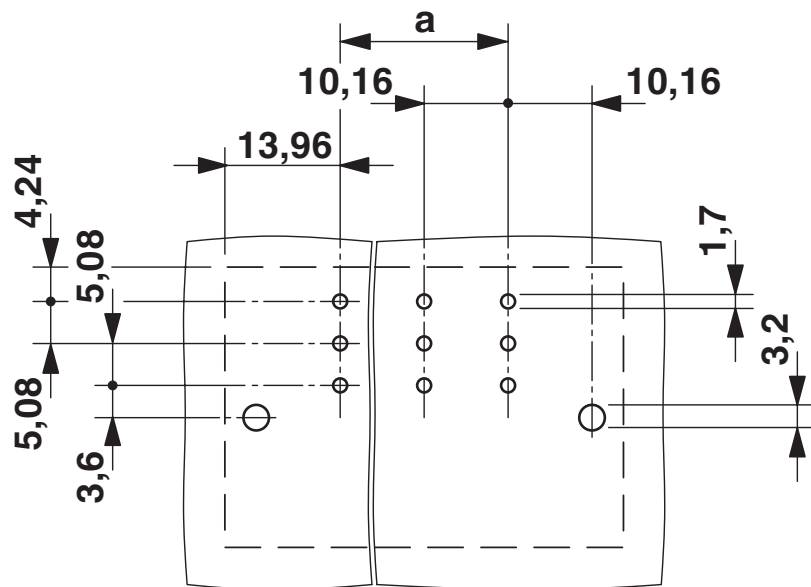

Dimensional drawing

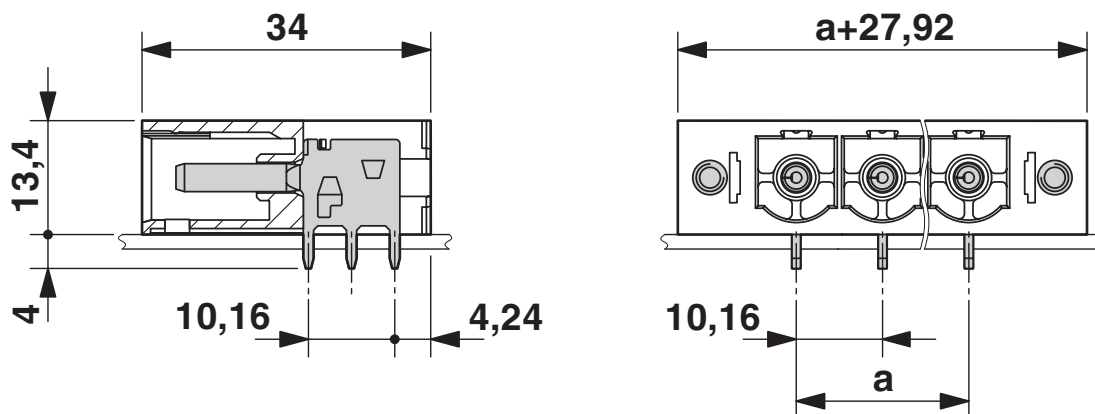

Diagram

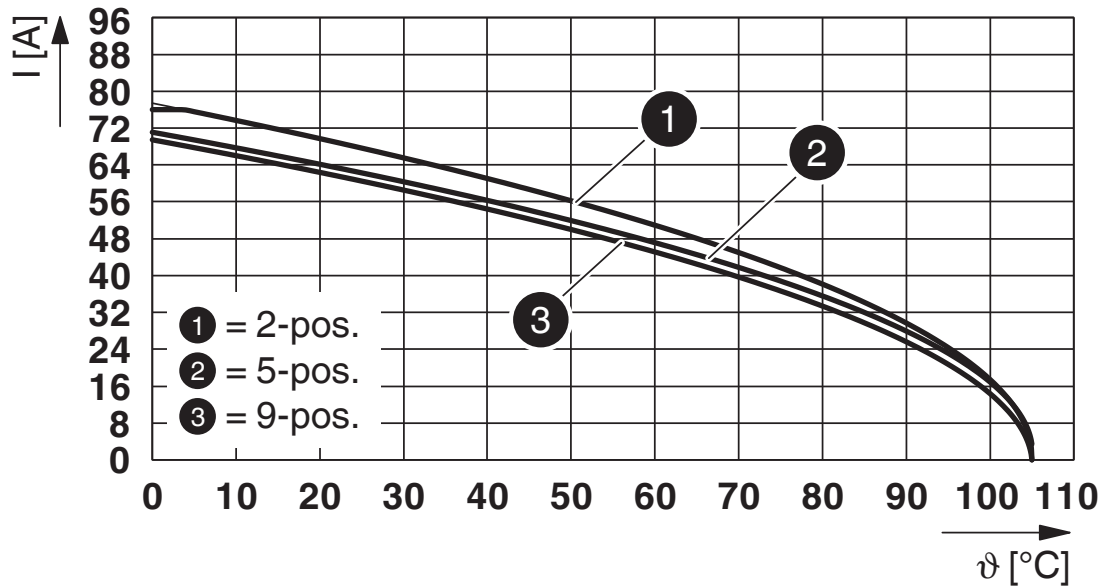

Type: PC 16/...-STF-10,16 with PC 6-16/...-G1F-10,16

Diagram

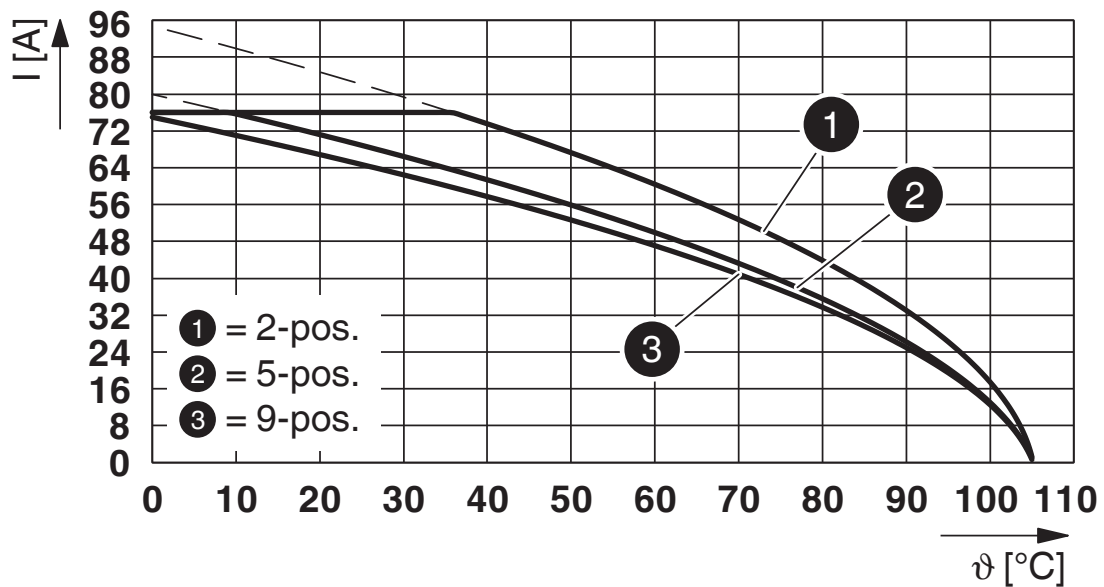

Type: SPC 16/...-STF-10,16 with PC 6-16/...-G1F-10,16

# PC 6-16/ 3-G1F-10,16 - PCB header



1999013

<https://www.phoenixcontact.com/in/products/1999013>

## Approvals



**EAC**

Approval ID: B.01687



**cULus Recognized**

Approval ID: E60425-20040202

	Nominal Voltage $U_N$	Nominal Current $I_N$	Cross Section AWG	Cross Section $\text{mm}^2$
	300 V	66 A	-	-
	300 V	66 A	-	-
	600 V	5 A	-	-



**IECEE CB Scheme**

Approval ID: DE1-66677

	Nominal Voltage $U_N$	Nominal Current $I_N$	Cross Section AWG	Cross Section $\text{mm}^2$
	-	76 A	-	-



**VDE Zeichengenehmigung**

Approval ID: 40055586

	Nominal Voltage $U_N$	Nominal Current $I_N$	Cross Section AWG	Cross Section $\text{mm}^2$
	-	76 A	-	-



# PC 6-16/ 3-G1F-10,16 - PCB header



1999013

<https://www.phoenixcontact.com/in/products/1999013>

## Classifications

### ECLASS

ECLASS-11.0	27460201
ECLASS-12.0	27460201
ECLASS-13.0	27460201

### ETIM

ETIM 8.0	EC002637
----------	----------

### UNSPSC

UNSPSC 21.0	39121400
-------------	----------

# PC 6-16/ 3-G1F-10,16 - PCB header



1999013

<https://www.phoenixcontact.com/in/products/1999013>

## Environmental Product Compliance

China RoHS	Environmentally friendly use period: unlimited = EFUP-e
	No hazardous substances above threshold values

# PC 6-16/ 3-G1F-10,16 - PCB header

1999013

<https://www.phoenixcontact.com/in/products/1999013>

## Accessories

### CP-PC RD - Coding profile

1701967

<https://www.phoenixcontact.com/in/products/1701967>

Coding profile, for plugging into the coding ribs of the plug at a later date, insulating material, color: Red

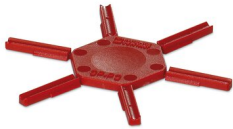

---

### DFK-PC 16-SS - Accessories

1705449

<https://www.phoenixcontact.com/in/products/1705449>

Screw set for DFK-PC 16... connectors



# PC 6-16/ 3-G1F-10,16 - PCB header

1999013

<https://www.phoenixcontact.com/in/products/1999013>

## SPC 16/ 3-STF-10,16 - PCB connector

1711381

<https://www.phoenixcontact.com/in/products/1711381>

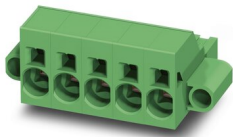

PCB connector, nominal cross section: 16 mm<sup>2</sup>, color: green, nominal current: 76 A, rated voltage (III/2): 1000 V, contact surface: Silver, type of contact: Socket, number of potentials: 3, number of rows: 1, number of positions: 3, number of connections: 3, product range: SPC 16/..-STF, pitch: 10.16 mm, connection method: Push-in spring connection, conductor/PCB connection direction: 0 °, locking clip: - without locking clip, plug-in system: COMBICON PC 16, locking: Screw locking, mounting: Screw flange, type of packaging: packed in cardboard

---

## TPC 16/ 3-STF-10,16 - PCB connector

1715264

<https://www.phoenixcontact.com/in/products/1715264>



PCB connector, nominal cross section: 16 mm<sup>2</sup>, color: green, nominal current: 76 A, rated voltage (III/2): 1000 V, contact surface: Silver, type of contact: Socket, number of potentials: 3, number of rows: 1, number of positions: 3, number of connections: 6, product range: TPC 16/..-STF, pitch: 10.16 mm, connection method: Screw connection with tension sleeve, screw head form: L Slotted, conductor/PCB connection direction: 50 °, locking clip: - without locking clip, plug-in system: COMBICON PC 16, locking: Screw locking, mounting: Screw flange, type of packaging: packed in cardboard

# PC 6-16/ 3-G1F-10,16 - PCB header

1999013

<https://www.phoenixcontact.com/in/products/1999013>

## PC 6/ 3-STF-10,16 - PCB connector

1913581

<https://www.phoenixcontact.com/in/products/1913581>



PCB connector, nominal cross section: 6 mm<sup>2</sup>, color: green, nominal current: 41 A, rated voltage (III/2): 1000 V, contact surface: Silver, type of contact: Socket, number of potentials: 3, number of rows: 1, number of positions: 3, number of connections: 3, product range: PC 6/..-STF, pitch: 10.16 mm, connection method: Screw connection with tension sleeve, screw head form: L Slotted, conductor/PCB connection direction: 0 °, locking clip: - without locking clip, plug-in system: COMBICON PC 16, locking: Screw locking, mounting: Screw flange, type of packaging: packed in cardboard

---

## PC 16/ 3-STF-10,16 - PCB connector

1967469

<https://www.phoenixcontact.com/in/products/1967469>



PCB connector, nominal cross section: 16 mm<sup>2</sup>, color: green, nominal current: 76 A, rated voltage (III/2): 1000 V, contact surface: Silver, type of contact: Socket, number of potentials: 3, number of rows: 1, number of positions: 3, number of connections: 3, product range: PC 16/..-STF, pitch: 10.16 mm, connection method: Screw connection with tension sleeve, screw head form: L Slotted, conductor/PCB connection direction: 0 °, locking clip: - without locking clip, plug-in system: COMBICON PC 16, locking: Screw locking, mounting: Screw flange, type of packaging: packed in cardboard

---

Phoenix Contact 2023 © - all rights reserved  
<https://www.phoenixcontact.com>

PHOENIX CONTACT (I) Pvt. Ltd.  
A-58/2, Okhla Industrial Area, Phase - II, New Delhi-110 020

+91.1275.71420  
[info@phoenixcontact.co.in](mailto:info@phoenixcontact.co.in)