

# Product data sheet

Specifications



## Motion servo drive, Lexium 32, single phase supply voltage 115/230 V, 0.8/1.6 kW

LXM32MD30M2

### Main

Range of product	Lexium 32
Product or component type	Motion servo drive
Device short name	LXM32M
Format of the drive	Book
Network number of phases	Single phase
[Us] rated supply voltage	100...120 V - 15...10 % 200...240 V - 15...10 %
Supply voltage limits	85...132 V 170...264 V
Supply frequency	50/60 Hz - 5...5 %
Network frequency	47.5...63 Hz
EMC filter	Integrated
Continuous output current	10 A at 8 kHz
Output current 3s peak	15 A at 115 V for 5 s
Maximum continuous power	800 W at 115 V 5600 W at 230 V
Nominal power	0.8 kW at 115 V 8 kHz 1.6 kW at 230 V 8 kHz
Line current	11.6 A 74 % at 380 V, with external line choke of 1 mH 9.6 A 85 % at 480 V, with external line choke of 1 mH 12.9 A 135 % at 115 V, without line choke 9.8 A 146 % at 380 V, without line choke

### Complementary

Switching frequency	8 kHz
Overvoltage category	III
Maximum leakage current	30 mA
Output voltage	<= power supply voltage
Electrical isolation	Between power and control
Type of cable	Single-strand IEC cable (temperature: 50 °C) copper 90 °C XLPE/EPR
Electrical connection	Terminal, clamping capacity: 3 mm <sup>2</sup> , AWG 12 (CN8) Terminal, clamping capacity: 5 mm <sup>2</sup> , AWG 10 (CN1) Terminal, clamping capacity: 5 mm <sup>2</sup> , AWG 10 (CN10)
Tightening torque	CN8: 0.5 N.m CN1: 0.7 N.m

<b>Discrete input number</b>	2 capture discrete input(s) 2 safety discrete input(s) 4 logic discrete input(s)
<b>Discrete input type</b>	Capture (CAP terminals) Logic (DI terminals) Safety (compliment of STO_A, compliment of STO_B terminals)
<b>Sampling duration</b>	DI: 0.25 ms discrete 0.25 ms
<b>Discrete input voltage</b>	24 V DC for capture 24 V DC for logic 24 V DC for safety
<b>Discrete input logic</b>	Positive (compliment of STO_A, compliment of STO_B) at State 0: < 5 V at State 1: > 15 V conforming to EN/IEC 61131-2 type 1 Positive (DI) at State 0: > 19 V at State 1: < 9 V conforming to EN/IEC 61131-2 type 1 Positive or negative (DI) at State 0: < 5 V at State 1: > 15 V conforming to EN/IEC 61131-2 type 1
<b>Response time</b>	<= 5 ms compliment of STO_A, compliment of STO_B
<b>Discrete output number</b>	3
<b>Discrete output type</b>	Logic output(s) (DO) 24 V DC
<b>Discrete output voltage</b>	<= 30 V DC
<b>Discrete output logic</b>	Positive or negative (DO) conforming to EN/IEC 61131-2
<b>Contact bounce time</b>	<= 1 ms for compliment of STO_A, compliment of STO_B 2 µs for CAP 0.25 µs...1.5 ms for DI
<b>Braking current</b>	50 mA
<b>Response time on output</b>	250 µs (DO) for discrete output(s)
<b>Control signal type</b>	Servo motor encoder feedback Pulse train output (PTO) RS422 <500 kHz <100 m Pulse/direction (P/D), A/B, CW/CCW 5 V, 24 V link (open collector) <10 kHz <1 m Pulse/direction (P/D), A/B, CW/CCW 5 V, 24 V link (push-pull) <200 kHz <10 m Pulse/direction (P/D), A/B, CW/CCW RS422 <1000 kHz <100 m
<b>Protection type</b>	Against reverse polarity: inputs signal Against short-circuits: outputs signal
<b>Safety function</b>	STO (safe torque off), integrated SS1 (safe stop 1), with separated eSM safety card SS2 (safe stop 2), with separated eSM safety card SLS (safe limited speed), with separated eSM safety card SOS (safe operating stop), with separated eSM safety card
<b>Safety level</b>	SIL 3 conforming to EN/IEC 61508 PL = e conforming to ISO 13849-1
<b>Communication interface</b>	Modbus, integrated CANopen, with separated communication card CANmotion, with separated communication card Ethernet/IP, with separated communication card EtherCAT, with separated communication card Profibus, with separated communication card DeviceNet, with separated communication card I/O, with separated communication card Profinet
<b>Connector type</b>	RJ45 (labelled CN7) for Modbus
<b>Commissioning port</b>	2-wire RS485 multidrop for Modbus
<b>Transmission rate</b>	9600, 19200, 38400 bps for bus length of 40 m for Modbus
<b>Number of addresses</b>	1...247 for Modbus
<b>Status LED</b>	1 LED (red) servo drive voltage
<b>Signalling function</b>	Display of faults 7 segments
<b>Marking</b>	CE
<b>Operating position</b>	Vertical +/- 10 degree
<b>Product compatibility</b>	Servo motor BMH (70 mm, 2 motor stacks) Servo motor BMH (140 mm, 1 motor stacks) Servo motor BSH (100 mm, 3 motor stacks) Servo motor BSH (100 mm, 4 motor stacks) Servo motor BSH (140 mm, 1 motor stacks)

<b>Width</b>	68 mm
<b>Height</b>	270 mm
<b>Depth</b>	237 mm
<b>Net weight</b>	2.1 kg

## Environment

<b>Electromagnetic compatibility</b>	<p>Conducted EMC, class A group 1 conforming to EN 55011  Conducted EMC, class A group 2 conforming to EN 55011  Conducted EMC, environment 2 category C3 conforming to EN/IEC 61800-3  Conducted EMC, category C2 conforming to EN/IEC 61800-3  Conducted EMC, environments 1 and 2 conforming to EN/IEC 61800-3  Electrostatic discharge immunity test, level 3 conforming to EN/IEC 61000-4-2  Susceptibility to electromagnetic fields, level 3 conforming to EN/IEC 61000-4-3  1.2/50 µs shock waves immunity test, level 3 conforming to EN/IEC 61000-4-5  Electrical fast transient/burst immunity test, level 4 conforming to EN/IEC 61000-4-4  Radiated EMC, class A group 2 conforming to EN 55011  Radiated EMC, category C3 conforming to EN/IEC 61800-3</p>
<b>Standards</b>	<p>EN/IEC 61800-5-1  EN/IEC 61800-3</p>
<b>Product certifications</b>	<p>TÜV  UL  CSA</p>
<b>IP degree of protection</b>	<p>IP20 conforming to EN/IEC 60529  IP20 conforming to EN/IEC 61800-5-1</p>
<b>Vibration resistance</b>	<p>1 gn (f= 13...150 Hz) conforming to EN/IEC 60068-2-6  1.5 mm peak to peak (f= 3...13 Hz) conforming to EN/IEC 60068-2-6</p>
<b>Shock resistance</b>	<p>15 gn for 11 ms conforming to EN/IEC 60028-2-27</p>
<b>Pollution degree</b>	<p>2 conforming to EN/IEC 61800-5-1</p>
<b>Environmental characteristic</b>	<p>Classes 3C1 conforming to IEC 60721-3-3</p>
<b>Relative humidity</b>	<p>Class 3K3 (5 to 85 %) without condensation conforming to IEC 60721-3-3</p>
<b>Ambient air temperature for operation</b>	<p>0...50 °C conforming to UL</p>
<b>Ambient air temperature for storage</b>	<p>-25...70 °C</p>
<b>Type of cooling</b>	<p>Integrated fan</p>
<b>Operating altitude</b>	<p>&lt;= 1000 m without derating  &gt; 1000...3000 m with conditions</p>

## Packing Units

<b>Unit Type of Package 1</b>	PCE
<b>Number of Units in Package 1</b>	1
<b>Package 1 Height</b>	11 cm
<b>Package 1 Width</b>	27.5 cm
<b>Package 1 Length</b>	33 cm
<b>Package 1 Weight</b>	2.524 kg
<b>Unit Type of Package 2</b>	S03
<b>Number of Units in Package 2</b>	2
<b>Package 2 Height</b>	30 cm
<b>Package 2 Width</b>	30 cm
<b>Package 2 Length</b>	40 cm
<b>Package 2 Weight</b>	6.039 kg
<b>Unit Type of Package 3</b>	P06
<b>Number of Units in Package 3</b>	16

Package 3 Height	60 cm
Package 3 Width	80 cm
Package 3 Length	60 cm
Package 3 Weight	54.588 kg

## Offer Sustainability

Sustainable offer status	Green Premium product
REACH Regulation	<a href="#">REACH Declaration</a>
EU RoHS Directive	Pro-active compliance (Product out of EU RoHS legal scope) <a href="#">EU RoHS Declaration</a>
Mercury free	Yes
China RoHS Regulation	<a href="#">China RoHS declaration</a>
RoHS exemption information	Yes
Environmental Disclosure	<a href="#">Product Environmental Profile</a>
Circularity Profile	<a href="#">End of Life Information</a>
WEEE	The product must be disposed on European Union markets following specific waste collection and never end up in rubbish bins
PVC free	Yes
California proposition 65	WARNING: This product can expose you to chemicals including: Lead and lead compounds, which is known to the State of California to cause cancer and birth defects or other reproductive harm. For more information go to <a href="http://www.P65Warnings.ca.gov">www.P65Warnings.ca.gov</a>

## Contractual warranty

Warranty	18 months
----------	-----------

Lexium 32 Servo Drive

---

Dimensions

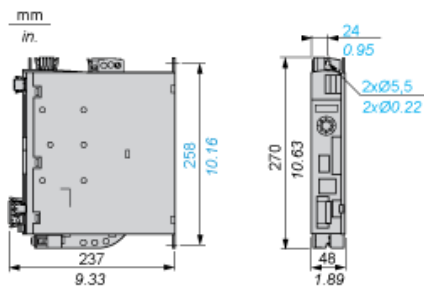

**Lexium 32 Motion Control Servo Drives**

**Mounting Recommendations**

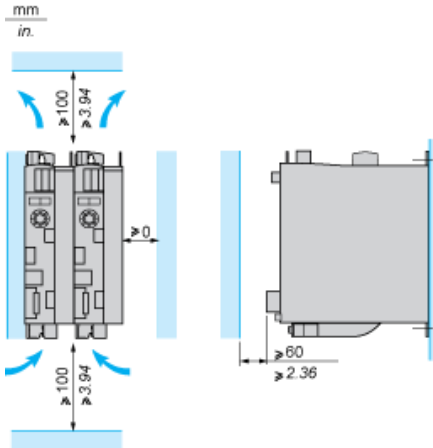

LXM32•U45M2, •U90M2 and LXM32•U60N4 servo drives are cooled by natural convection. LXM32•D18M2, •D30M2, LXM32 •D12N4, •D18N4, •D30N4 and •D72N4servo drives have an integrated fan.

When installing the servo drive in the enclosure, follow the instructions below with regard to the temperature and protection index:

- Provide sufficient cooling of the servo drive
- Do not mount the servo drive near heat sources
- Do not mount the servo drive on flammable materials
- Do not heat the servo drive cooling air by currents of hot air from other equipment and components, for example from an external braking resistor
- Mount the servo drive vertically ( $\pm 10\%$ )
- If the servo drive is used above its thermal limits, control stops due to overtemperature

NOTE: For cables that are connected via the underside of the servo drive, a free space  $\geq 200$  mm/7.87 in. is required under the unit to comply with the bending radius of the connection cables.

Ambient temperature	Mounting distances	Instructions to be followed
0°C...+ 50°C	$d \geq 0$ mm	–
+ 50°C...+ 60°C	$d \geq 0$ mm	Reduce the output current by 2.2% per °C above 50°C

NOTE: Do not use insulated enclosures, as they have a poor level of conductivity.

**Recommendations for Mounting in an Enclosure**

To ensure good air circulation in the servo drive:

- Fit ventilation grilles on the enclosure.
- Ensure that ventilation is adequate, otherwise install a forced ventilation unit with a filter.

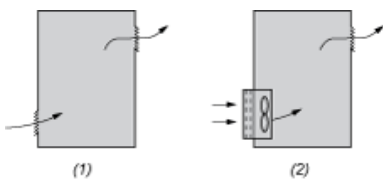

- (1) Natural convection
- (2) Forced ventilation

- Any apertures and/or fans must provide a flow rate at least equal to that of the servo drive fans (refer to characteristics).
- Use special filters with IP 54 protection.

**Mounting in Metal Enclosure (IP 54 Degree of Protection)**

The servo drive must be mounted in a dust and damp proof enclosure in certain environmental conditions, such as dust, corrosive gases, high humidity with risk of condensation and dripping water, splashing liquid, etc. In these cases, Lexium 32 servo drives can be installed in an enclosure where the internal temperature must not exceed 60°C.

**Recommended replacement(s)**