

A-INL-PG42-P-LG - Counter nut



1424556

<https://www.phoenixcontact.com/pc/products/1424556>

Please be informed that the data shown in this PDF document is generated from our Online Catalog. Please find the complete data in the user documentation. Our General Terms of Use for Downloads are valid.

Counter nut, connecting thread: Pg42, color: light grey



Commercial Data

Item number	1424556
Packing unit	5 pc
Minimum order quantity	1 pc
Product Key	BF7DZX
Catalog Page	Page 687 (C-2-2019)
GTIN	4055626374604
Weight per Piece (including packing)	13.94 g
Weight per Piece (excluding packing)	13.94 g
Customs tariff number	39269097
Country of origin	TR

A-INL-PG42-P-LG - Counter nut

1424556

<https://www.phoenixcontact.com/pc/products/1424556>

Technical Data

Product properties

Product type	Flat nut
--------------	----------

Dimensions

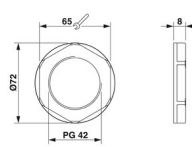
Dimensional drawing	
Length	8 mm
Diameter	54 mm
Connecting thread diameter	54 mm
Wrench size, counter nut	65 mm
Hexagon angular dimension	73 mm
Thread type connection side	Pg42

Material specifications

Color	light grey
Flammability rating according to UL 94	V2
Material (GRP)	PA 6.6 GF

Cable/line

Halogen-free	yes
--------------	-----

Environmental and real-life conditions

Ambient conditions

Ambient temperature (operation)	-40 °C ... 100 °C
---------------------------------	-------------------

A-INL-PG42-P-LG - Counter nut

1424556

<https://www.phoenixcontact.com/pc/products/1424556>



Drawings

Dimensional drawing

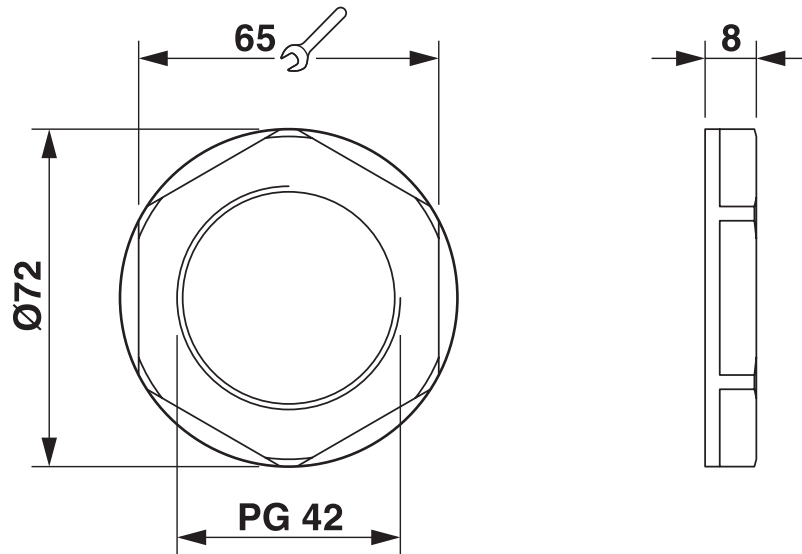

A-INL-PG42-P-LG - Counter nut



1424556

<https://www.phoenixcontact.com/pc/products/1424556>

Classifications

ECLASS

ECLASS-11.0	27144424
ECLASS-13.0	27140807

ETIM

ETIM 8.0	EC000940
----------	----------

UNSPSC

UNSPSC 21.0	31161700
-------------	----------

A-INL-PG42-P-LG - Counter nut



1424556

<https://www.phoenixcontact.com/pc/products/1424556>

Environmental Product Compliance

China RoHS	Environmentally friendly use period: unlimited = EFUP-e
	No hazardous substances above threshold values

Phoenix Contact 2023 © - all rights reserved
<https://www.phoenixcontact.com>

PHOENIX CONTACT GmbH & Co. KG
Flachmarktstraße 8
D-32825 Blomberg
+49 (0) 5235-3 00
info@phoenixcontact.com