

A-INL-M12-S-S - Counter nut

1425175

<https://www.phoenixcontact.com/in/products/1425175>

Please be informed that the data shown in this PDF document is generated from our Online Catalog. Please find the complete data in the user documentation. Our General Terms of Use for Downloads are valid.

Counter nut, for threads M12 x 1.5, color: silver



Commercial Data

Item number	1425175
Packing unit	10 pc
Minimum order quantity	10 pc
Sales Key	BF7
Product Key	BF7DZX
Catalog Page	Page 692 (C-2-2019)
GTIN	4055626385464
Weight per Piece (including packing)	2.18 g
Weight per Piece (excluding packing)	2.18 g
Customs tariff number	73269098
Country of origin	DE

A-INL-M12-S-S - Counter nut

1425175

<https://www.phoenixcontact.com/in/products/1425175>

Technical Data

Product properties

Product type	Flat nut
Thread type	M12

Dimensions

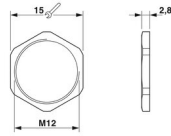
Dimensional drawing	
Length	2.8 mm
Diameter	12 mm
Connecting thread diameter	12 mm
Wrench size, counter nut	15 mm
Hexagon angular dimension	16.5 mm
Thread type connection side	M12 x 1.5
Thread pitch	1.5 mm

Material specifications

Color	silver
Material (GRP)	Stainless steel 1.4305

Cable/line

Halogen-free	yes
--------------	-----

Environmental and real-life conditions

Ambient conditions

Ambient temperature (operation)	-70 °C ... 220 °C
---------------------------------	-------------------

A-INL-M12-S-S - Counter nut

1425175

<https://www.phoenixcontact.com/in/products/1425175>



Drawings

Dimensional drawing

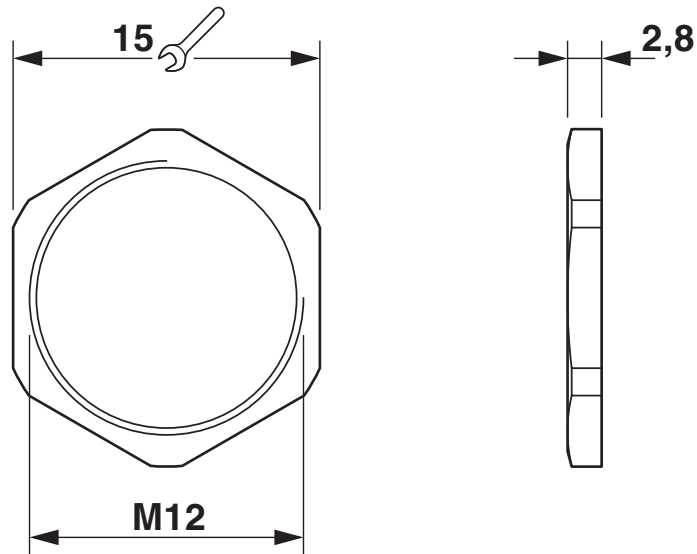

Dimensional drawing

A-INL-M12-S-S - Counter nut



1425175

<https://www.phoenixcontact.com/in/products/1425175>

Classifications

ECLASS

ECLASS-11.0	27144424
ECLASS-13.0	27140807

ETIM

ETIM 8.0	EC000940
----------	----------

UNSPSC

UNSPSC 21.0	31161700
-------------	----------

A-INL-M12-S-S - Counter nut



1425175

<https://www.phoenixcontact.com/in/products/1425175>

Environmental Product Compliance

China RoHS	Environmentally friendly use period: unlimited = EFUP-e No hazardous substances above threshold values
------------	---

Phoenix Contact 2023 © - all rights reserved
<https://www.phoenixcontact.com>

PHOENIX CONTACT (I) Pvt. Ltd.
A-58/2, Okhla Industrial Area, Phase - II, New Delhi-110 020

+91.1275.71420
info@phoenixcontact.co.in