

Product data sheet

Specifications



Harmony XVM, aluminium support tube with metal bracket l=250 mm,

XVMZ03T

Main

Range of product	Harmony XVM
Accessory / separate part designation	Ø 20 mm aluminium support tube with metal bracket
Accessory / separate part category	Mounting and fixing accessories
Accessory / separate part destination	Beacons and indicator banks Ø 45 mm

Complementary

Accessory / separate part type	Support tube with bracket
Product compatibility	XVM.
Colour	Aluminium
Height under base unit	263 mm
Length	250 mm
Net weight	0.242 kg

Packing Units

Unit Type of Package 1	PCE
Number of Units in Package 1	1
Package 1 Height	29.1 cm
Package 1 Width	3.5 cm
Package 1 Length	6.1 cm
Package 1 Weight	243.0 g
Unit Type of Package 2	S02
Number of Units in Package 2	15
Package 2 Height	15.0 cm
Package 2 Width	30.0 cm
Package 2 Length	40.0 cm
Package 2 Weight	4.135 kg
Unit Type of Package 3	PAL
Number of Units in Package 3	240

Package 3 Height	60.0 cm
Package 3 Width	80.0 cm
Package 3 Length	240.0 cm
Package 3 Weight	147.12 kg

Offer Sustainability

Sustainable offer status	Green Premium product
REACH Regulation	REACH Declaration
EU RoHS Directive	Pro-active compliance (Product out of EU RoHS legal scope) EU RoHS Declaration
Mercury free	Yes
China RoHS Regulation	China RoHS declaration
RoHS exemption information	Yes
Environmental Disclosure	Product Environmental Profile
California proposition 65	WARNING: This product can expose you to chemicals including: Lead and lead compounds, which is known to the State of California to cause cancer and birth defects or other reproductive harm. For more information go to www.P65Warnings.ca.gov

Contractual warranty

Warranty	18 months
----------	-----------

Dimensions and Mounting

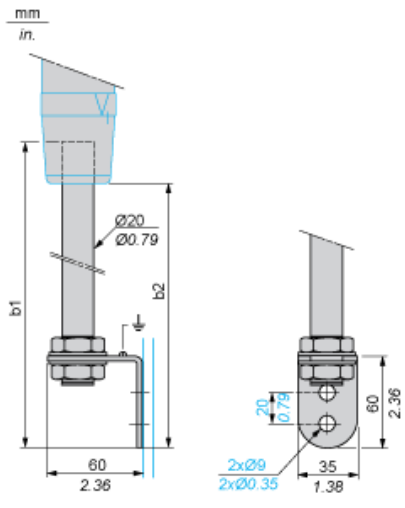

Support tube length		b1 (tube + plate)		b2 (height under base unit)	
mm	in.	mm	in.	mm	in.
250	9.84	283	11.14	256	10.08

Panel Cut-Out

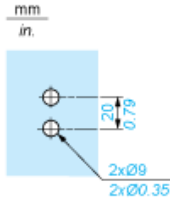

Recommended replacement(s)