

Product datasheet

Specifications



Motion servo drive, Lexium 32, three phase, supply Voltage 208...480V, 1.8kW

LXM32AD18N4

Main

Range of product	Lexium 32
Product or component type	Motion servo drive
Device short name	LXM32A
Format of the drive	Book
Network number of phases	Three phase
[Us] rated supply voltage	200...240 V - 15...10 % 380...480 V - 15...10 %
Supply voltage limits	170...264 V 323...528 V
Supply frequency	50/60 Hz - 5...5 %
Network frequency	47.5...63 Hz
EMC filter	Integrated
Continuous output current	6 A at 8 kHz
Output current 3s peak	18 A for 5 s
Maximum continuous power	1500 W at 230 V 3300 W at 400 V
Nominal power	1.2 kW at 230 V 8 kHz 1.8 kW at 400 V 8 kHz
Line current	7.2 A 88 % at 380 V, with external line choke of 1 mH 6 A 98 % at 480 V, with external line choke of 1 mH 4.5 A 165 % at 480 V, without line choke 6.2 A 159 % at 380 V, without line choke

Complementary

Switching frequency	8 kHz
Overvoltage category	III
Maximum leakage current	30 mA
Output voltage	<= power supply voltage
Electrical isolation	Between power and control
Type of cable	Single-strand IEC cable (temperature: 50 °C) copper 90 °C XLPE/EPR
Electrical connection	Terminal, clamping capacity: 3 mm ² , AWG 12 (CN8) Terminal, clamping capacity: 5 mm ² , AWG 10 (CN1) Terminal, clamping capacity: 5 mm ² , AWG 10 (CN10)
Tightening torque	CN8: 0.5 N.m CN1: 0.7 N.m

CN10: 0.7 N.m

Discrete input number	1 capture discrete input(s) 2 safety discrete input(s) 4 logic discrete input(s)
Discrete input type	Capture (CAP terminals) Logic (DI terminals) Safety (compliment of STO_A, compliment of STO_B terminals)
Sampling duration	DI: 0.25 ms discrete
Discrete input voltage	24 V DC for capture 24 V DC for logic 24 V DC for safety
Discrete input logic	Positive (compliment of STO_A, compliment of STO_B) at State 0: < 5 V at State 1: > 15 V conforming to EN/IEC 61131-2 type 1 Positive (DI) at State 0: > 19 V at State 1: < 9 V conforming to EN/IEC 61131-2 type 1 Positive or negative (DI) at State 0: < 5 V at State 1: > 15 V conforming to EN/IEC 61131-2 type 1
Response time	<= 5 ms compliment of STO_A, compliment of STO_B
Discrete output number	2
Discrete output type	Logic output(s) (DO) 24 V DC
Discrete output voltage	<= 30 V DC
Discrete output logic	Positive or negative (DO) conforming to EN/IEC 61131-2
Contact bounce time	<= 1 ms for compliment of STO_A, compliment of STO_B 2 µs for CAP 0.25 µs...1.5 ms for DI
Braking current	50 mA
Response time on output	250 µs (DO) for discrete output(s)
Control signal type	Servo motor encoder feedback
Protection type	Against reverse polarity: inputs signal Against short-circuits: outputs signal
Safety function	STO (safe torque off), integrated
Safety level	SIL 3 conforming to EN/IEC 61508 PL = e conforming to ISO 13849-1
Communication interface	CANmotion, integrated CANopen, integrated Modbus, integrated
Connector type	RJ45 (labelled CN4 or CN5) for CANmotion RJ45 (labelled CN4 or CN5) for CANopen RJ45 (labelled CN7) for Modbus
Method of access	Slave
Commissioning port	2-wire RS485 multidrop for Modbus
Transmission rate	1 Mbps for bus length of 4 m for CANopen, CANmotion 125 kbps for bus length of 500 m for CANopen, CANmotion 250 kbps for bus length of 250 m for CANopen, CANmotion 50 kbps for bus length of 1000 m for CANopen, CANmotion 500 kbps for bus length of 100 m for CANopen, CANmotion 9600, 19200, 38400 bps for bus length of 40 m for Modbus
Number of addresses	1...127 for CANopen, CANmotion 1...247 for Modbus
Communication service	1 receive SDO for CANmotion 1 transmit SDO for CANmotion 2 PDOs conforming to DSP 402 for CANmotion 2 SDOs receive for CANopen 2 SDOs send for CANopen 4 configurable mapping PDOs for CANopen CANopen device profile drives and motion control for CANopen, CANmotion Display of faults on integrated display terminal for Modbus Emergency for CANopen, CANmotion Event-triggered, time-triggered, remotely requested, sync (cyclic), sync (acyclic) for CANopen Node guarding, heartbeat for CANopen Position control mode for CANmotion Position control, speed profile, torque profile and homing mode for CANopen Sync for CANmotion
Status LED	1 LED (red) servo drive voltage 1 LED error 1 LED RUN

Signalling function	Display of faults 7 segments
Marking	CE
Operating position	Vertical +/- 10 degree
Product compatibility	Servo motor BMH (100 mm, 1 motor stacks) Servo motor BMH (70 mm, 3 motor stacks) Servo motor BSH (70 mm, 3 motor stacks) Servo motor BSH (100 mm, 1 motor stacks) Servo motor BMH (100 mm, 2 motor stacks) Servo motor BSH (100 mm, 2 motor stacks)
Width	48 mm
Height	270 mm
Depth	237 mm
Net weight	2 kg

Environment

Electromagnetic compatibility	Conducted EMC, class A group 1 conforming to EN 55011 Conducted EMC, class A group 2 conforming to EN 55011 Conducted EMC, environment 2 category C3 conforming to EN/IEC 61800-3 Conducted EMC, category C2 conforming to EN/IEC 61800-3 Conducted EMC, environments 1 and 2 conforming to EN/IEC 61800-3 Electrostatic discharge immunity test, level 3 conforming to EN/IEC 61000-4-2 Susceptibility to electromagnetic fields, level 3 conforming to EN/IEC 61000-4-3 1.2/50 µs shock waves immunity test, level 3 conforming to EN/IEC 61000-4-5 Electrical fast transient/burst immunity test, level 4 conforming to EN/IEC 61000-4-4 Radiated EMC, class A group 2 conforming to EN 55011 Radiated EMC, category C3 conforming to EN/IEC 61800-3
Standards	EN/IEC 61800-3 EN/IEC 61800-5-1
Product certifications	TÜV UL CSA
IP degree of protection	IP20 conforming to EN/IEC 60529 IP20 conforming to EN/IEC 61800-5-1
Vibration resistance	1 gn (f= 13...150 Hz) conforming to EN/IEC 60068-2-6 1.5 mm peak to peak (f= 3...13 Hz) conforming to EN/IEC 60068-2-6
Shock resistance	15 gn for 11 ms conforming to EN/IEC 60028-2-27
Pollution degree	2 conforming to EN/IEC 61800-5-1
Environmental characteristic	Classes 3C1 conforming to IEC 60721-3-3
Relative humidity	Class 3K3 (5 to 85 %) without condensation conforming to IEC 60721-3-3
Ambient air temperature for operation	0...50 °C conforming to UL
Ambient air temperature for storage	-25...70 °C
Type of cooling	Integrated fan
Operating altitude	<= 1000 m without derating > 1000...3000 m with conditions

Packing Units

Unit Type of Package 1	PCE
Number of Units in Package 1	1
Package 1 Height	8.500 cm
Package 1 Width	27.500 cm
Package 1 Length	32.500 cm
Package 1 Weight	2.431 kg
Unit Type of Package 2	S03
Number of Units in Package 2	3

Package 2 Height	30.000 cm
Package 2 Width	30.000 cm
Package 2 Length	40.000 cm
Package 2 Weight	7.710 kg
Unit Type of Package 3	P06
Number of Units in Package 3	24
Package 3 Height	75.000 cm
Package 3 Width	80.000 cm
Package 3 Length	60.000 cm
Package 3 Weight	69.680 kg

Offer Sustainability

Sustainable offer status	Green Premium product
REACH Regulation	REACH Declaration
EU RoHS Directive	Pro-active compliance (Product out of EU RoHS legal scope) EU RoHS Declaration
Mercury free	Yes
China RoHS Regulation	China RoHS declaration
RoHS exemption information	Yes
Environmental Disclosure	Product Environmental Profile
Circularity Profile	End of Life Information
WEEE	The product must be disposed on European Union markets following specific waste collection and never end up in rubbish bins
PVC free	Yes

Contractual warranty

Warranty	18 months
----------	-----------

Lexium 32 Servo Drive

Dimensions

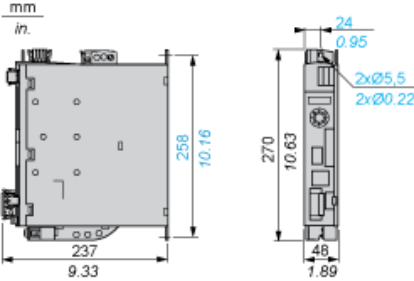

Lexium 32 Motion Control Servo Drives

Mounting Recommendations

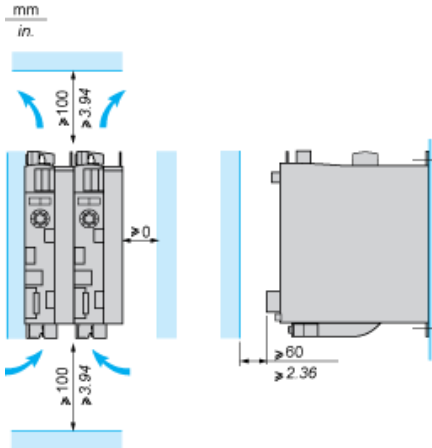

LXM32•U45M2, •U90M2 and LXM32•U60N4 servo drives are cooled by natural convection. LXM32•D18M2, •D30M2, LXM32 •D12N4, •D18N4, •D30N4 and •D72N4servo drives have an integrated fan.

When installing the servo drive in the enclosure, follow the instructions below with regard to the temperature and protection index:

- Provide sufficient cooling of the servo drive
- Do not mount the servo drive near heat sources
- Do not mount the servo drive on flammable materials
- Do not heat the servo drive cooling air by currents of hot air from other equipment and components, for example from an external braking resistor
- Mount the servo drive vertically ($\pm 10\%$)
- If the servo drive is used above its thermal limits, control stops due to overtemperature

NOTE: For cables that are connected via the underside of the servo drive, a free space ≥ 200 mm/7.87 in. is required under the unit to comply with the bending radius of the connection cables.

Ambient temperature	Mounting distances	Instructions to be followed
0°C...+ 50°C	$d \geq 0$ mm	–
+ 50°C...+ 60°C	$d \geq 0$ mm	Reduce the output current by 2.2% per °C above 50°C

NOTE: Do not use insulated enclosures, as they have a poor level of conductivity.

Recommendations for Mounting in an Enclosure

To ensure good air circulation in the servo drive:

- Fit ventilation grilles on the enclosure.
- Ensure that ventilation is adequate, otherwise install a forced ventilation unit with a filter.

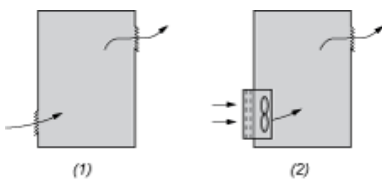

- (1) Natural convection
- (2) Forced ventilation

- Any apertures and/or fans must provide a flow rate at least equal to that of the servo drive fans (refer to characteristics).
- Use special filters with IP 54 protection.

Mounting in Metal Enclosure (IP 54 Degree of Protection)

The servo drive must be mounted in a dust and damp proof enclosure in certain environmental conditions, such as dust, corrosive gases, high humidity with risk of condensation and dripping water, splashing liquid, etc. In these cases, Lexium 32 servo drives can be installed in an enclosure where the internal temperature must not exceed 60°C.

Recommended replacement(s)