

mat'l. code		surface ISO 1302 ✓		tolerance ISO 406 ISO 1101		projection		product family CONAN®	
ltr	ecn no	dr	date	tolerances unless otherwise specified		INCH/MM		title	
AG	ELX-N-14208	GM	2013-03-17	angles	linear	.0±.30		CONAN® CONNECTOR ASSEMBLY	
AH	ELX-N-22454	EH	2015-10-11			.00±.20		dwg no	
AJ	-	EH	2015-12-12	0°±x'		.000±.10		sheet 1 of 7	
AK	ELX-N-26578	TONY	2017-04-07	dr	Eric Huang	2015-10-11		size	
AL	ELX-N-26810	TONY	2017-04-26	engr	Bob Gu	2020-06-04		A3	
AM	ELX-N-35652	Bob	2019-12-17	chr	LQ Lei	2020-06-04		91900	
AN	ELX-N-37277	Bob	2020-06-04	appd	Tim Yao	2020-06-04		type Product Customer Drawing	
sheet	revision	AL	AM	AN					
index	sheet	1	7	2					

PRODUCT NUMBER
SEE TABLE

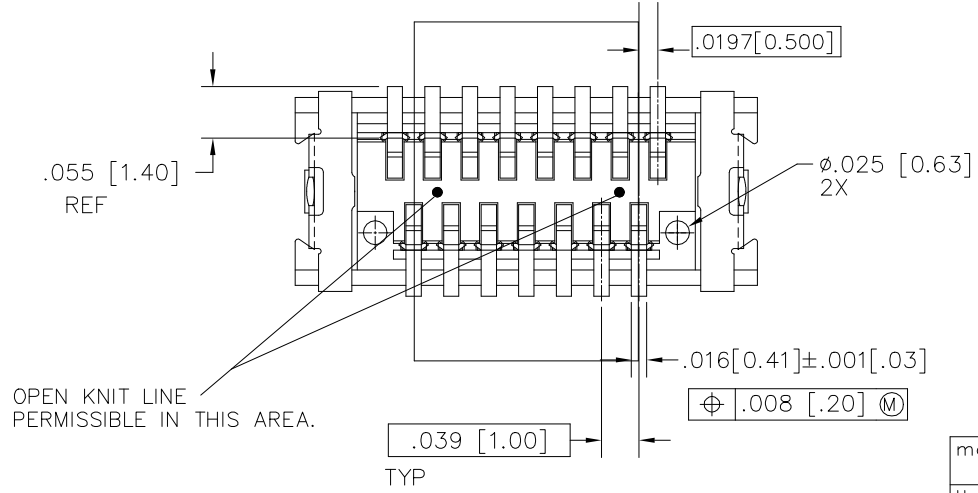
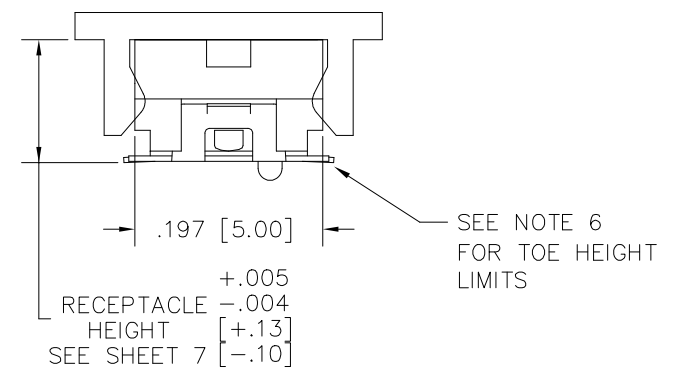
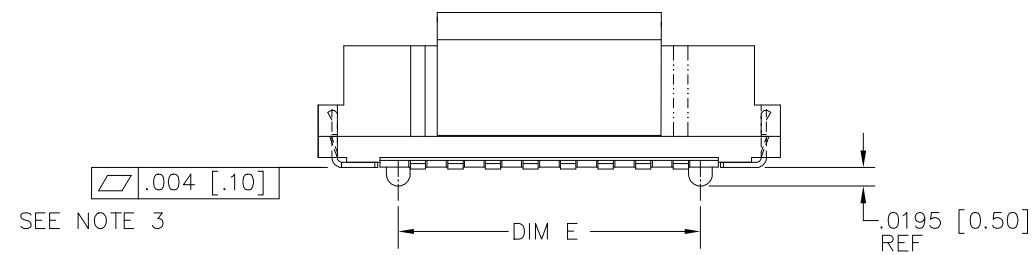
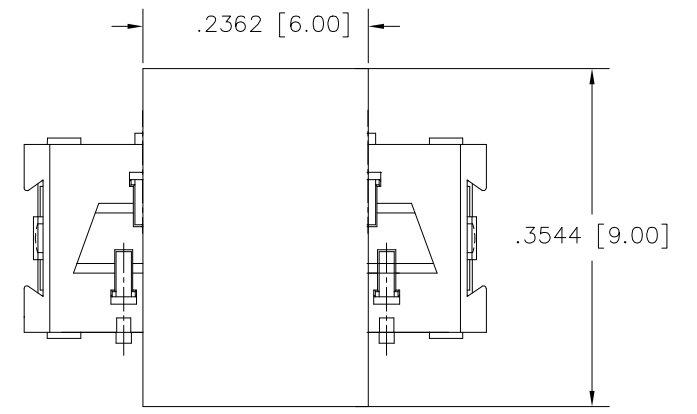
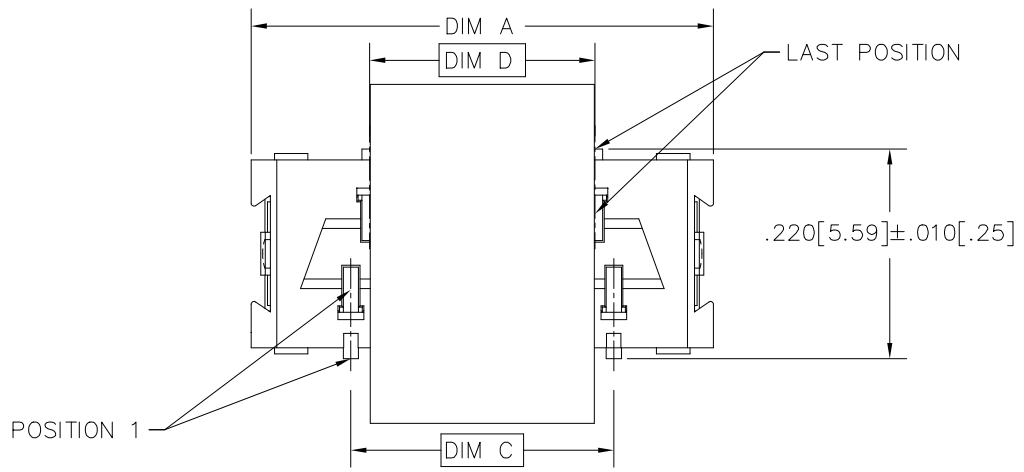

mat'l. code		surface ISO 1302 ✓	tolerance ISO 406 ISO 1101	projection 1101	product family CONAN®
ltr	ecn no	dr	date	tolerances unless otherwise specified	title
AN				linear .0±.30 angular .00±.20 0°±x' .000±.10	CONAN® CONNECTOR ASSEMBLY
				scale 1:1	dwg no 91900
		dr	Eric Huang	2019-12-17	sheet 2 of 7
		engr	Bob Gu	2020-06-04	size A3
		chr	LQ Lei	2020-06-04	
		appd	Tim Yao	2020-06-04	
sheet index	revision sheet				type Product Customer Drawing

Amphenol FCI
 © 2016 AFCE
 © 2016 AFCE
 © 2016 AFCE

PRODUCT NUMBER
SEE TABLE

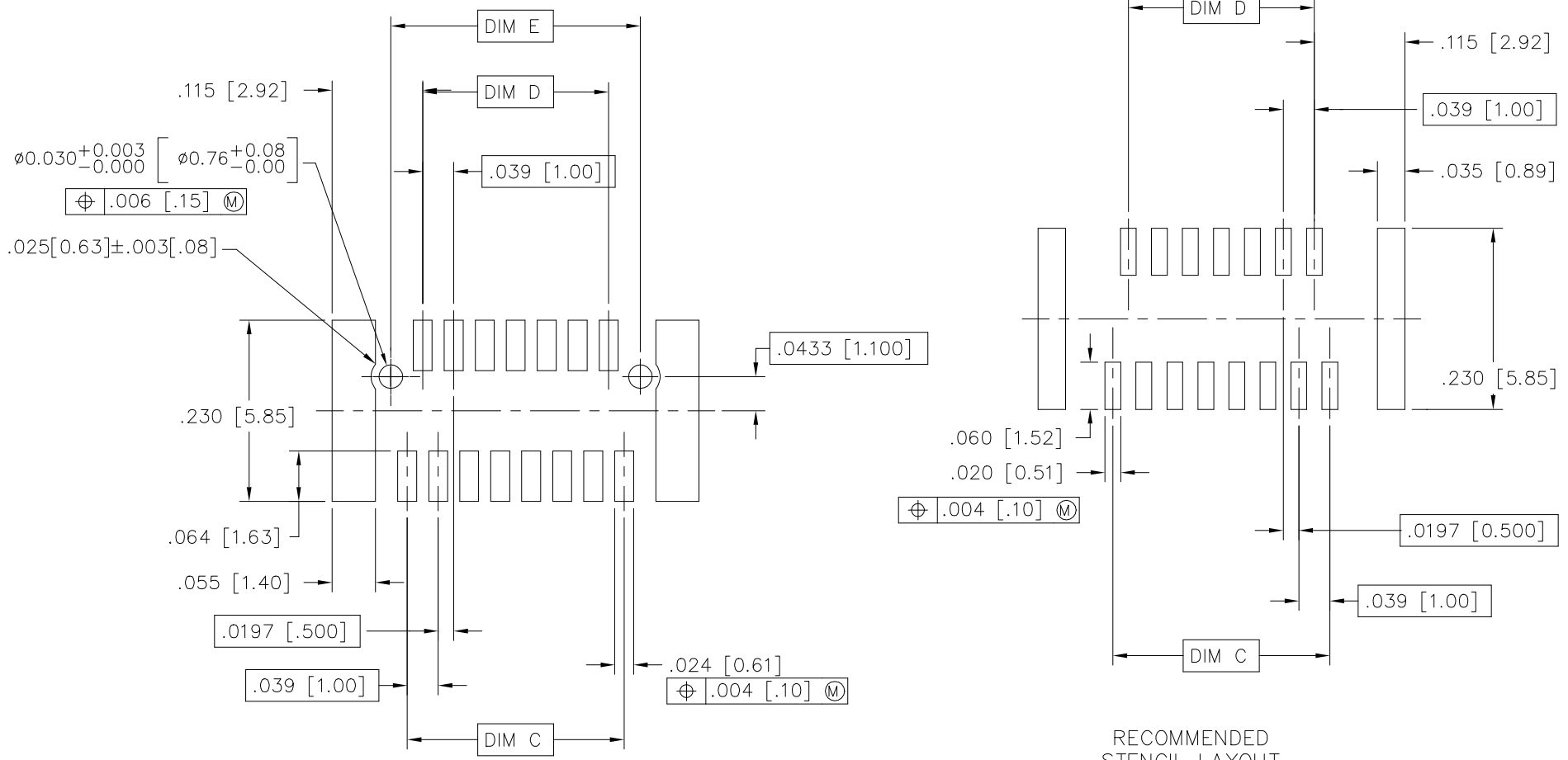

© 2016 AFCI

mat'l. code		surface ISO 1302 <input checked="" type="checkbox"/>		tolerance ISO 406 ISO 1101		projection		product family CONAN®	
ltr	ecn no	dr	date	tolerances unless otherwise specified		INCH/MM		title	
AN				angles	linear	.0±.30		CONAN® CONNECTOR ASSEMBLY	
				0°±x'		.00±.20		sheet 3 of 7	
				dr	Eric Huang	2019-12-17		size A3	
				enr	Bob Gu	2020-06-04	Amphenol FCI	dwg no 91900	
				chr	LQ Lei	2020-06-04		type Product Customer Drawing	
				appd	Tim Yao	2020-06-04			
sheet index	revision sheet								

PRODUCT NUMBER
SEE TABLE

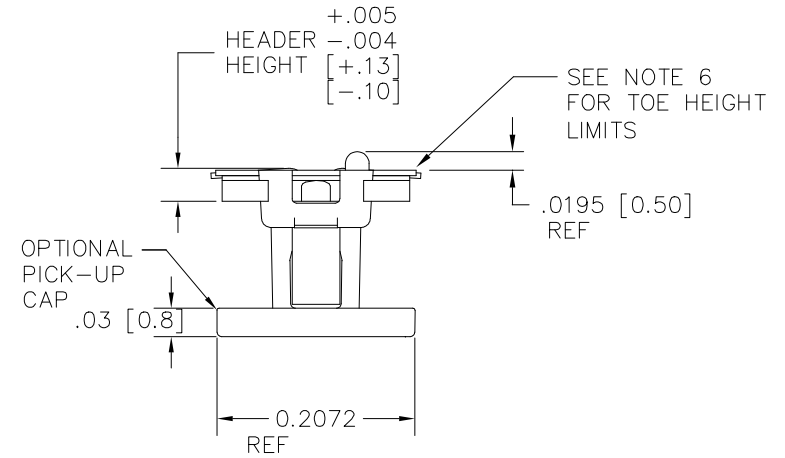
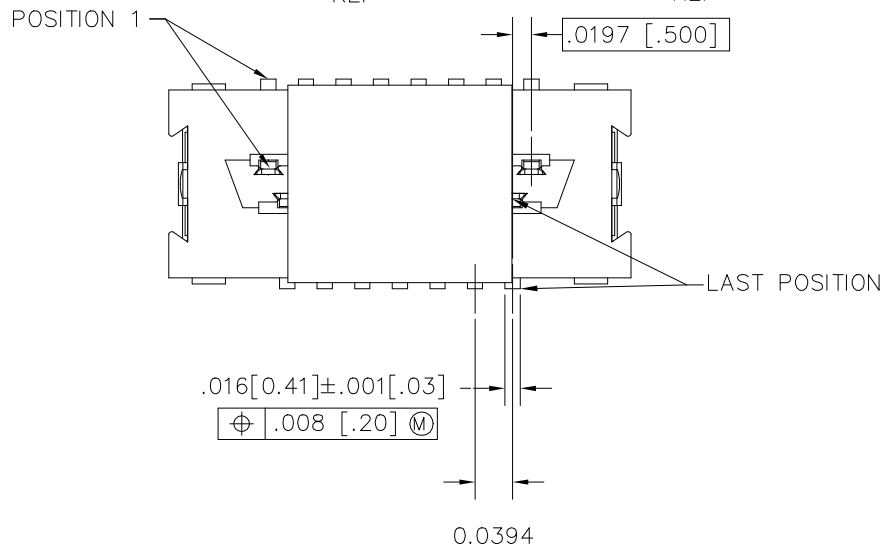
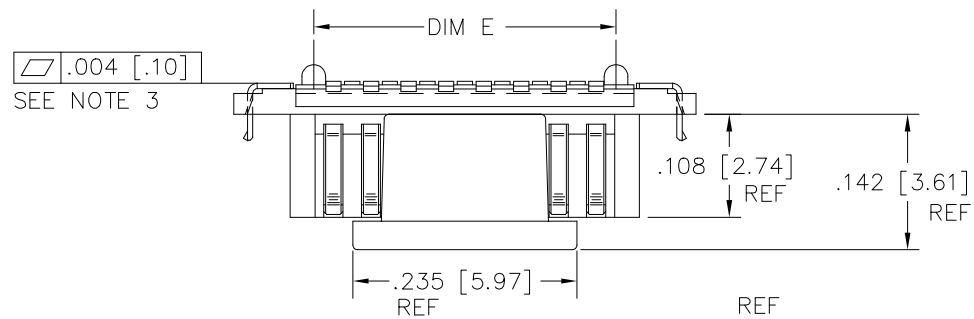
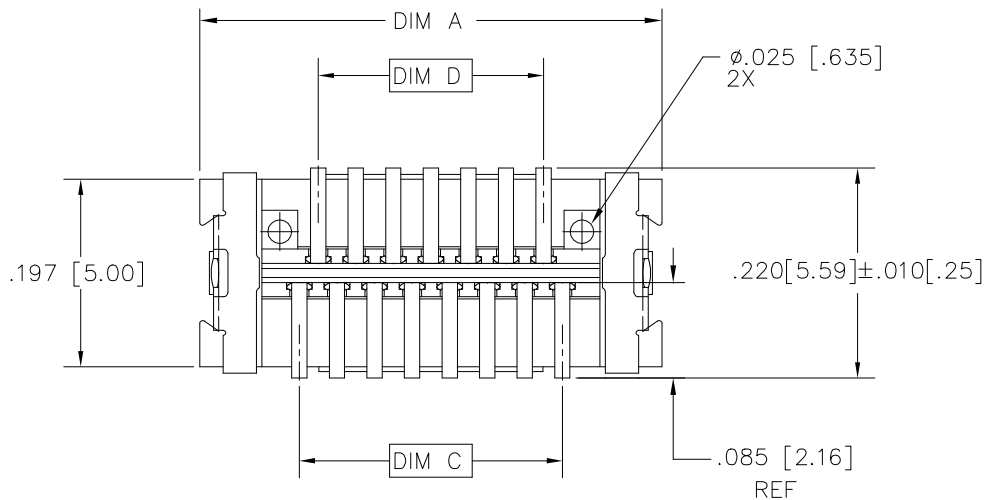

mat'l. code		surface	tolerance	projection	product family
		ISO 1302 ✓	ISO 406 ISO 1101		CONAN®
ltr	ecn no	dr	date	tolerances unless otherwise specified	title
AN				linear	CONAN® CONNECTOR ASSEMBLY
				0°±x'	INCH/MM
				.0±.30	scale 1:1
				.00±.20	
				.000±.10	
		dr	Eric Huang	2019-12-17	Amphenol FCI
		engr	Bob Gu	2020-06-04	CONAN® CONNECTOR ASSEMBLY
		chr	LQ Lei	2020-06-04	91900
		appd	Tim Yao	2020-06-04	sheet 4 of 7
					size A3
					type Product Customer Drawing
sheet index	revision sheet				

PRODUCT NUMBER
SEE TABLE

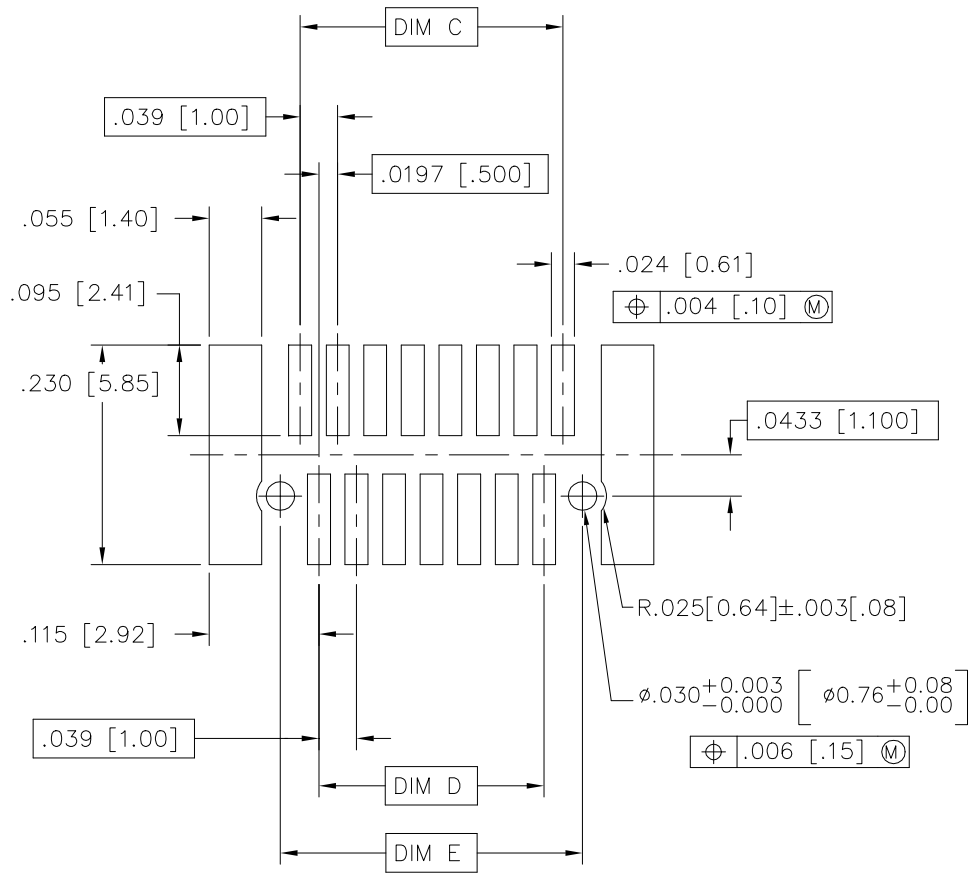

RECOMMENDED
PAD LAYOUT

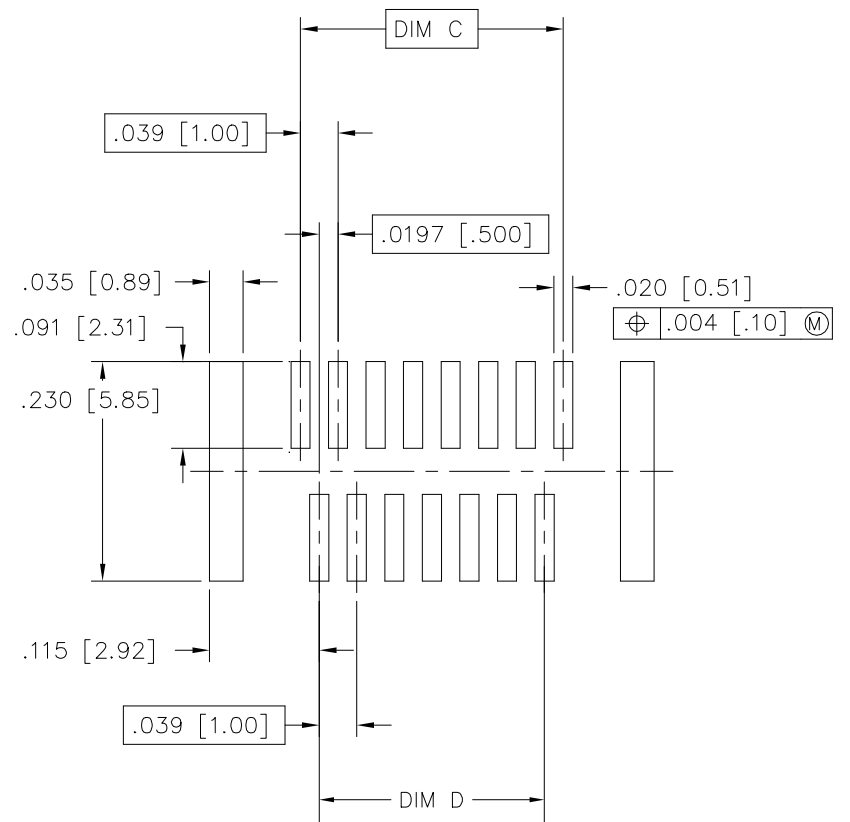

RECOMMENDED
STENCIL LAYOUT
FOR HEADER

mat'l. code		surface ISO 1302 ✓		tolerance ISO 406 ISO 1101		projection ISO 1101		product family CONAN®	
ltr	ecn no	dr	date	tolerances unless otherwise specified		INCH/MM		title	
AN				angles	linear	.0±.30		CONAN® CONNECTOR ASSEMBLY	
				0°±x'		.00±.20		dwg no	
						.000±.10	scale 1:1	sheet 5 of 7	
				dr	Eric Huang	2019-12-17	Amphenol FCI	size	
				engr	Bob Gu	2020-06-04		A3	
				chr	LQ Lei	2020-06-04		91900	
				appd	Tim Yao	2020-06-04		type Product Customer Drawing	
sheet index	revision sheet								

PRODUCT NUMBER	POS	DIM "A"	DIM "C"	DIM "D"	DIM "E"
919TC-WXY09	9	.366 [9.30]	.157 [4.00]	.118 [3.00]	.1990 [5.055]
-WXY09LF					
-WXY11	11	.406 [10.30]	.197 [5.00]	.157 [4.00]	.2380 [6.045]
-WXY11LF					
-WXY15	15	.484 [12.30]	.276 [7.00]	.236 [6.00]	.3170 [8.052]
-WXY15LF					
-WXY21	21	.602 [15.30]	.394 [10.00]	.354 [9.00]	.4350 [11.049]
-WXY21LF					
-WXY25	25	.681 [17.30]	.472 [12.00]	.433 [11.00]	.5140 [13.056]
-WXY25LF					
-WXY31	31	.800 [20.30]	.591 [15.00]	.551 [14.00]	.6320 [16.053]
-WXY31LF					
-WXY41	41	.996 [25.30]	.787 [20.00]	.748 [19.00]	.8290 [21.057]
-WXY41LF					
-WXY51	51	1.193 [30.30]	.984 [25.00]	.945 [24.00]	1.0260 [26.060]
-WXY51LF					
-WXY69	69	1.547 [39.30]	1.339 [34.00]	1.299 [33.00]	1.3800 [35.052]
-WXY69LF					

NOTES:

- MATERIALS:
RECEPTACLE HOUSING - LCP, UL-94V-0. COLOR: NATURAL.
RECEPTACLE TERMINALS - COPPER ALLOY, PLATED WITH 15u"/.38u GXT™ IN CONTACT AREA AND 100u"/2.54u Sn ON SOLDER LEGS WITH AN OVERALL 50u"/1.27u Ni UNDERPLATE.
HEADER HOUSING - LCP, UL-94V-0. COLOR: NATURAL.
HEADER TERMINALS - COPPER ALLOY, PLATED WITH 15u"/.38u GXT™ IN CONTACT AREA AND 100u"/2.54u Sn ON SOLDER LEGS WITH AN OVERALL 50u"/1.27u Ni UNDERPLATE.
RETENTION DEVICE - BRASS, PLATED WITH 100u"/2.54u Sn OVER NICKEL.
- REFERENCE GS-12-006 FOR PRODUCT PERFORMANCE DATA.
- SEE TA-774 FOR FURTHER DESCRIPTION OF HOW THIS DIMENSION IS APPLIED.
- PICK AND PLACE CAP OR TAPE IS ONLY AVAILABLE WITH OPTION 3 PACKAGING. (PSA ADHESIVE SEALED). ALSO, PSA PACKAGING REQUIRES A PICK AND PLACE CAP.
- RECOMMENDED SOLDER PASTE THICKNESS IS .006 TO .008 INCHES THICK.
- THE TOE HEIGHT OF THE SOLDER TAIL SHALL BE MEASURED FROM THE LOWEST POINT OF THE .004 CO-PLANARITY GRAVITY PLANE. THIS MEASUREMENT IS NOT TO EXCEED A WINDOW OF .000 TO .007 INCHES.
- THREE SLOTS MAY BE LOCATED AT EITHER END OF HOUSING.
- 5.50mm MATED HEIGHT IS ONLY AVAILABLE IN 9, 15 AND 31 POS.
- 7.50mm MATED HEIGHT IS ONLY AVAILABLE IN 9 POS.
- APPLIES TO 91921-3XYZZ AND 91931- 3XYZZ OPTIONS ONLY.
- THE HOUSING WILL WITHSTAND EXPOSURE TO 260°C PEAK TEMPERATURE FOR 30 SECONDS IN A CONVECTION INFRA RED OR VAPOR PHASE REFLOW OVEN. SEE APPLICATION/PROCEDURES IF THEY ARE AVAILABLE
- PRODUCT WITH "LF" AT THE END MEETS EUROPEAN UNION DIRECTIVES AND OTHER COUNTRY REGULATION AS DESCRIBED IN GS-22-008.

A

B

C

D



© 2016 AFCI

mat'l. code		surface ISO 1302 <input checked="" type="checkbox"/>		tolerance ISO 406 ISO 1101		projection		product family CONAN®	
ltr		ecn no		dr		date		title	
AN								CONAN® CONNECTOR ASSEMBLY	
		angles		linear		.0±.30		INCH/MM	
						.00±.20		scale 1:1	
						.000±.10		dwg no sheet6 of 7 size	
		dr		Eric Huang		2015-10-11		91900 A3	
		engr		Bob Gu		2020-06-04		Amphenol FCI	
		chr		LQ Lei		2020-06-04		type Product Customer Drawing	
		appd		Tim Yao		2020-06-04			
sheet index		revision sheet							

CONAN[®] ASSEMBLY PART NUMBER

919 T C - W X Y ZZ LF

LEAD FREE OPTION
SEE NOTE 12

TYPE	T
HEADER WITH NO PEGS	0
HEADER WITH PEGS	1
RECEPTACLE WITH NO PEGS	2
RECEPTACLE WITH PEGS	3

PICK AND PLACE CAP OR TAPE (NOTE 4)	C
WITHOUT CAP OR TAPE	0
WITH CAP	1
WITH TAPE (RECEPTACLE ONLY)	2

PACKAGING	W
TUBE	2
PRESSURE SEALED TAPE & REEL	3

NOTE 4

Y	HEADER HEIGHT	RECEPTACLE HEIGHT	MATED HEIGHT
1	.034 [.86]	.129 [3.28]	.163 [4.15]
2	.048 [1.23]	SEE Y=1 FOR ALL RECEPTACLES	.177 [4.50]
3	.068 [1.73]		.197 [5.00]
4	.107 [2.72]		.236 [6.00]
5	.1465 [3.721]		.276 [7.00]
* 6	.088 [2.23]		.216 [5.50]
** 7	.1665 [4.229]		.296 [7.52]

* NOTE 8
** NOTE 9

X	PLATING
1	15u"/.38u GXT [™]
2	30u"/.76u GXT [™]
3	Au 30u"/.76u

ZZ	NUMBER OF POSITIONS
09	9
11	11
15	15
21	21
25	25
31	31
41	41
51	51
69	69

EXAMPLE: 91921-31125LF
IS A CONAN[®] RECEPTACLE ASSEMBLY,
HAVING NO PEGS AND WITH A PICK AND PLACE CAP.
IT ALSO HAS GXT[™] PLATING, IS .13 [3.2] HIGH AND 25
POSITIONS AND IS PACKAGED IN PRESSURE SEALED TAPE,
REEL AND LEAD FREE.

mat'l. code		surface ISO 1302 ✓	tolerance ISO 406 ISO 1101	projection	product family CONAN [®]
ltr	ecn no	dr	date	tolerances unless otherwise specified	title
AN				angles linear	CONAN [®] CONNECTOR ASSEMBLY
				0°±x'	INCH/MM
				.0±.30	scale 1:1
				.00±.20	
				.000±.10	
		dr	Eric Huang	2015-10-11	dwg no
		engr	Bob Gu	2020-06-04	sheet 7 of 7
		chr	LQ Lei	2020-06-04	size
		appd	Tim Yao	2020-06-04	91900
					A3
					type Product Customer Drawing
sheet index	revision sheet				

Amphenol FCI

© 2016 AFCI