



Séries
DSX

SIZE 5 PLUG COAXIAL CONTACT FOR
RG 58, KX 15, RG 141 CABLES

Issue:
18 JULY 95

Page
1 / 1

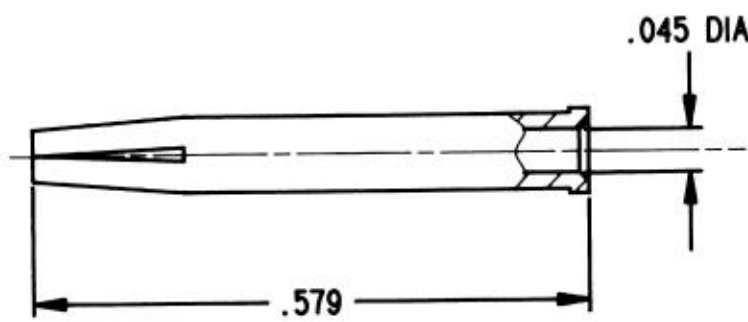
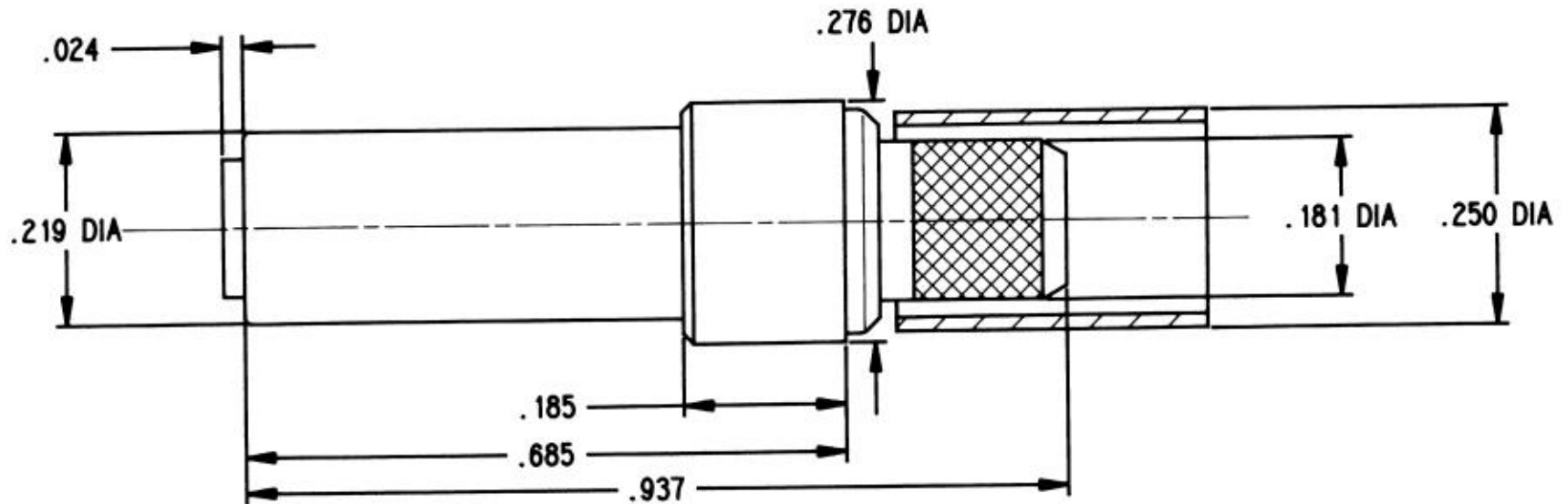

TRIMMING CABLE JACKET

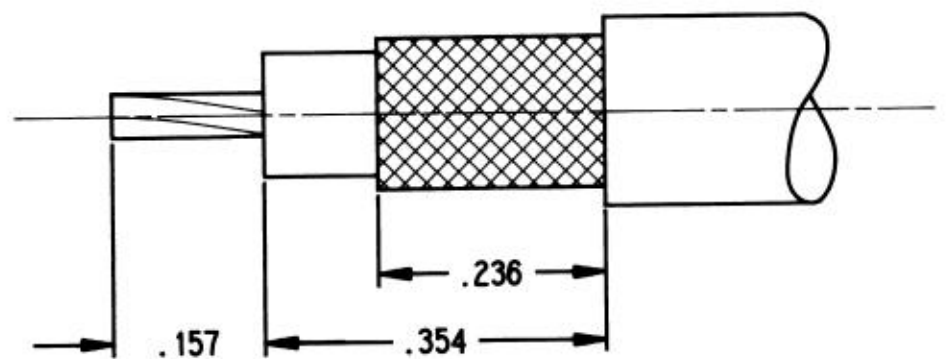

WIRING :

-CRIMPING CENTER CONTACT
CRIMPING TOOL : 282 281 (M22520/2-01) set position 6 for RG 58 and KX 15
8 for RG 141

POSITIONER : 282 974

-CRIMPING OUTER CONTACT
CRIMPING TOOL : 282 293 (M22520/5-01)
DIES 282 246 (M22520/5-05) HEX. IDENTIF. A .213 ON PLATS

This information is given as an indication. In the continual goal to improve our products, we reserve the right to make any modifications judged necessary.

4112_9311

CREATION				
PEN: .				
NOM: MACARI				
DATE: 28 APRIL 82	07 18 95	REDRAWN BY CAD	MOKHTARI	
APPR.:	Issue	Revisions	Name	Approved

616120A