

Product data sheet

Specifications



Regulated Power Supply, 100-240V AC, 24V 1.2 A, single phase, Modular

ABLM1A24012

Main

Range of product	Modicon Power Supply
Product or component type	Power supply
Power supply type	Regulated switch mode
Variant option	Modular
Enclosure material	Plastic
Nominal input voltage	100...240 V AC single phase 100...240 V AC 2 phases
Rated power in W	30 W
Output voltage	24 V DC
Power supply output current	1.25 A

Complementary

Input voltage limits	90...264 V AC
Nominal network frequency	50...60 Hz
Network system compatibility	TN TT IT
Maximum leakage current	0.25 mA 240 V AC
Input protection type	Integrated fuse (not interchangeable) 3.15 A External protection (recommended) 20 A Curve B External protection (recommended) 20 A Curve C External protection (recommended) 4 A Curve B External protection (recommended) 4 A Curve C
Inrush current	25 A at 115 V 50 A at 230 V
Power factor	0.48 at 115 V AC 0.38 at 230 V AC
Efficiency	87 % at 115 V AC 87 % at 230 V AC
Output voltage adjustment	24...28 V
Power dissipation in W	5 W
Current consumption	< 0.8 A 115 V AC < 0.6 A 230 V AC
Turn-on time	< 2 s
Holding time	> 20 ms 115 V AC > 60 ms 230 V AC

Disclaimer: This documentation is not intended as a substitute for and is not to be used for determining suitability or reliability of these products for specific user applications

Startup with capacitive loads	3000 µF
Residual ripple	< 100 mV
Meantime between failure [MTBF]	2500000 h at 25 °C, full load 1000000 h at 55 °C, 80 % load
Output protection type	Against overload and short-circuits, protection technology: automatic reset Against over temperature, protection technology: manual reset Against overvoltage, protection technology: manual reset
Connections - terminals	Screw connection: 0.5...1.5 mm ² , (AWG 20...AWG 16) without wire end ferrule for input/output Screw connection: 0.5...1 mm ² , (AWG 20...AWG 18) with wire end ferrule for input/output
Line and load regulation	< 0.5 % network in line < 1 % network 0 to 100 % load
Status LED	1 LED (green) output voltage
Depth	55.6 mm
Height	91 mm
Width	36 mm
Net weight	0.170 kg
Output coupling	Serial Parallel
Mounting support	Top hat type TH35-15 rail conforming to IEC 60715 Top hat type TH35-7.5 rail conforming to IEC 60715 Double-profile DIN rail panel mounting
Supply	SELV conforming to EN/IEC 60950-1 SELV conforming to EN/IEC 60204-1 SELV conforming to IEC 60364-4-41
Dielectric strength	3000 V AC input/output
Service life	10 year(s)

Environment

Standards	EN 62368-1 EN/IEC 61010-1 EN 61010-2-201 EN/IEC 61204-3 EN 61000-6-1 EN 61000-6-2 EN 61000-6-3 EN 61000-6-4 EN 61000-3-2 EN 61000-3-3 UL 62368-1 UL 61010-1 UL 61010-2-201 CSA C22.2 No 62368-1 CSA C22.2 No 61010-1 CSA C22.2 No 61010-2-201 EN/IEC 62368-1
Product certifications	CE CUL listed CUL recognized RCM CB Scheme EAC KC NEC: class 2
Operating altitude	< 2000 m overvoltage category III 2000 m...5000 m overvoltage category II
Shock resistance	100 m/s ² for 11 ms
IP degree of protection	IP20
Ambient air temperature for operation	-25...55 °C without current derating mounting position A < 2000 m 55...70 °C with current derating of 2.67 % per °C mounting position A < 2000 m
Electrical shock protection class	Class II without PE connection
Pollution degree	2

Vibration resistance	3 mm (f= 2...9 Hz) conforming to IEC 60721-3-3 10 m/s ² (f= 9...200 Hz) conforming to IEC 60721-3-3
Electromagnetic immunity	Immunity to electrostatic discharge - test level: 6 kV (contact discharge) conforming to EN/IEC 61000-4-2 Immunity to electrostatic discharge - test level: 9 kV (air discharge) conforming to EN/IEC 61000-4-2 Electromagnetic field immunity test - test level: 10 V/m (80 MHz...2 GHz) conforming to EN/IEC 61000-4-3 Electromagnetic field immunity test - test level: 5 V/m (2...2.7 GHz) conforming to EN/IEC 61000-4-3 Electromagnetic field immunity test - test level: 3 V/m (2.7...6 GHz) conforming to EN/IEC 61000-4-3 Immunity to fast transients - test level: 4 kV (on input-output) conforming to EN/IEC 61000-4-4 Surge immunity test - test level: 3 kV (between power supply and earth) conforming to EN/IEC 61000-4-5 Surge immunity test - test level: 1.5 kV (between phases) conforming to EN/IEC 61000-4-5 Immunity to conducted disturbances - test level: 10 Vrms (0.15...80 MHz) conforming to EN/IEC 61000-4-6 Immunity to magnetic fields - test level: 30 A/m (50...60 Hz) conforming to EN/IEC 61000-4-8 Immunity to voltage dips - test level: 100 % (1 cycle) conforming to EN/IEC 61000-4-11 Immunity to voltage dips - test level: 60 % (10 cycles) conforming to EN/IEC 61000-4-11 Immunity to voltage dips - test level: 30 % (25 cycles) conforming to EN/IEC 61000-4-11 Disturbing field emission conforming to EN 55016-2-3 Limits for harmonic current emissions conforming to EN 61000-3-2 Conducted disturbance emission conforming to EN 55016-1-2 Conducted disturbance emission conforming to EN 55016-2-1
Electromagnetic emission	Conducted emissions conforming to EN 61000-6-3 Radiated emissions conforming to EN 61000-6-4

Packing Units

Unit Type of Package 1	PCE
Number of Units in Package 1	1
Package 1 Height	5 cm
Package 1 Width	6 cm
Package 1 Length	11 cm
Package 1 Weight	172 g
Unit Type of Package 2	S02
Number of Units in Package 2	29
Package 2 Height	15 cm
Package 2 Width	30 cm
Package 2 Length	40 cm
Package 2 Weight	5.332 kg
Unit Type of Package 3	P12
Number of Units in Package 3	1392
Package 3 Height	105 cm
Package 3 Width	80 cm
Package 3 Length	120 cm
Package 3 Weight	267.936 kg

Offer Sustainability

Sustainable offer status	Green Premium product
REACH Regulation	REACH Declaration
EU RoHS Directive	Pro-active compliance (Product out of EU RoHS legal scope) EU RoHS Declaration
Mercury free	Yes
China RoHS Regulation	China RoHS declaration
RoHS exemption information	Yes
Environmental Disclosure	Product Environmental Profile
Circularity Profile	End of Life Information

WEEE

The product must be disposed on European Union markets following specific waste collection and never end up in rubbish bins

California proposition 65

WARNING: This product can expose you to chemicals including: Lead and lead compounds, which is known to the State of California to cause cancer and birth defects or other reproductive harm. For more information go to www.P65Warnings.ca.gov

Electrical Safety

- If the unit is use in a manner not specified by the manufacturer, the protection provided by the equipment may be impaired.
- For means of disconnection a switch or circuit breaker, located near the product, must be included in the installation. A marking as disconnecting device must be present.
- The device has an internal fuse. The unit is tested and approved with branch circuit protective device up to 20A. This circuit breaker can be used as disconnection device.
- The power supply is only suitable for audio, video, information, communication, industrial and control equipment.

Dimensions

Side and Rear View

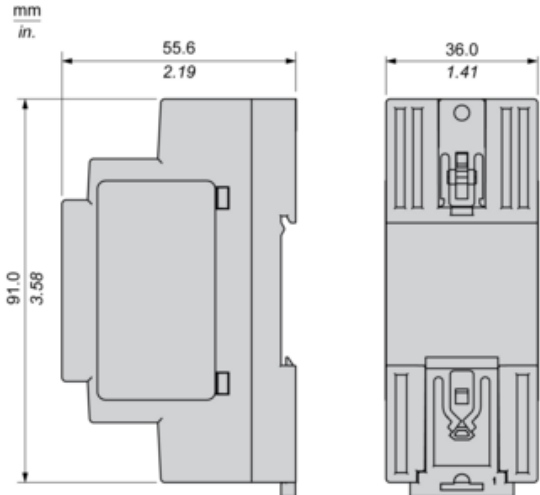

Connections and Schema

Correct Parallel Connection

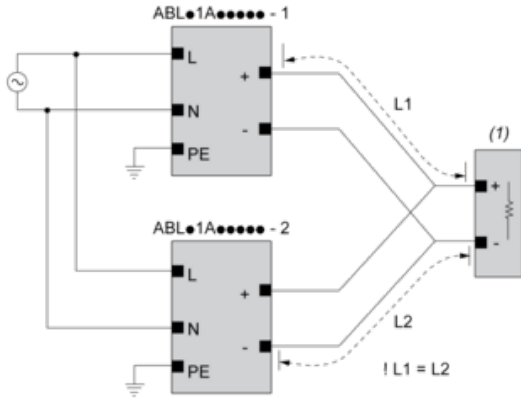

(1) : Load

Incorrect Parallel Connection

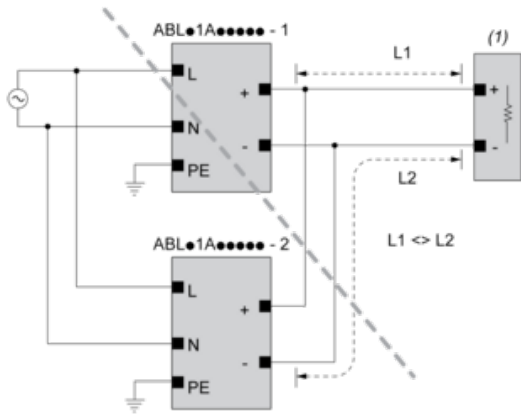

(1) : Load

$ABLx1Axxxxx-1 = ABLx1Axxxxx-2$

max 2 x $ABLx1Axxxxx$

$L1 = L2$

ΔV max 25 mV

$L_{Load} < 90\% \times L_{nom}$

Output Voltage Balancing

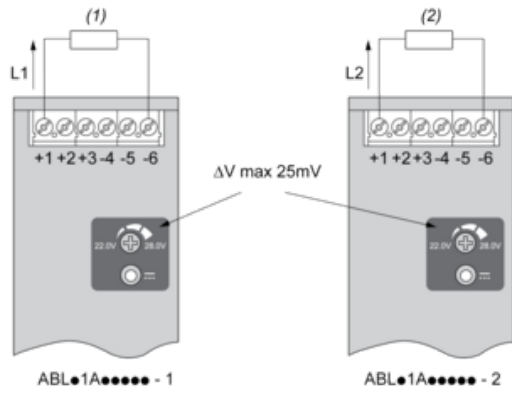

(1) : R_{Load1}

(2) : R_{Load2}

$R_{Load1} = R_{Load2}$

$I_1 = I_2 = \sim I_{nom}$

Series Connection

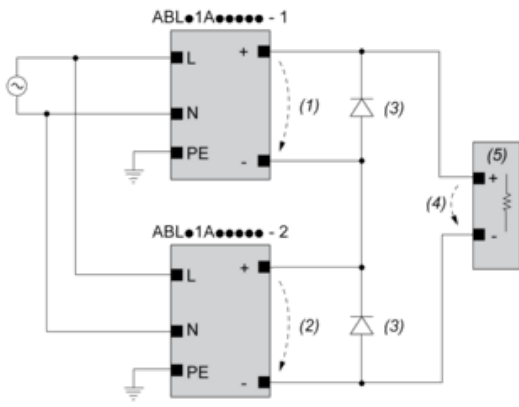

(1) : V_{out1}

(2) : V_{out2}

(3) : 2 x Diode, $V_{RRM} > 2 \times V_{out1/2}$, $I_F > 2 \times I_{nom1/2}$

(4) : $V_{Load} = 2 \times V_{out}$

(5) : Load

Connections and Schema

		(1)		
		<40°C	<50°C	<70°C
ABLM1A24004		60°C	75°C	75°C
ABLM1A12010		60°C	75°C	90°C
ABLM1A24006		60°C	75°C	90°C
ABLM1A05036	Input	60°C	75°C	90°C
	Output	75°C	90°C	90°C
ABLM1A12021		60°C	75°C	90°C
ABLM1A24012		60°C	75°C	90°C
ABLM1A12042		60°C	75°C	90°C
ABLM1A24025		60°C	75°C	90°C

(1) : Ambient

Performance Curve

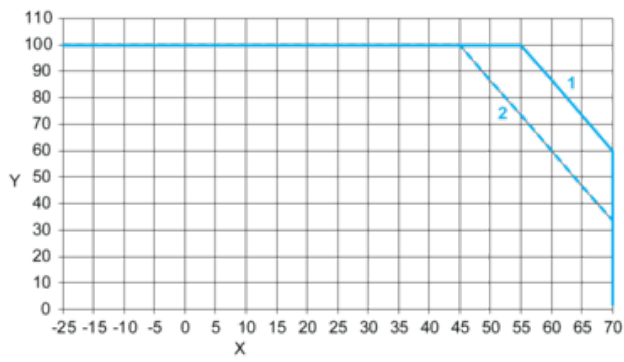

X : Ambient Temperature (°C)

Y : Percentage of Max Load (%)

1 : Mounting A & B, altitude 2000M

2 : Mounting A & B, altitude 5000M

Mounting

Mounting Position A

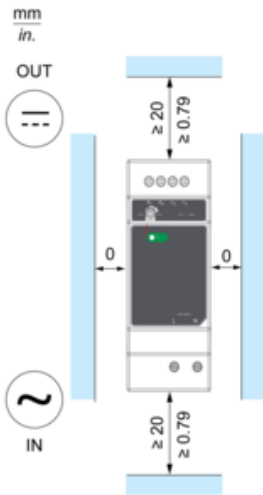

Mounting Position B

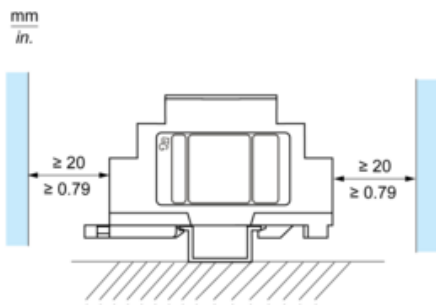

Incorrect Mounting

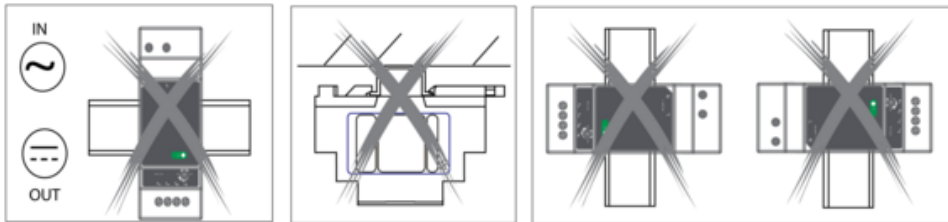

Recommended replacement(s)