

Product data sheet

Specifications



Regulated Power Supply, 100...240V AC, 24V 6.2A, single phase, Panel Mount

ABLP1A24062

Main

Range of product	Modicon Power Supply
Product or component type	Power supply
Power supply type	Regulated switch mode
Variant option	Panel mount
Enclosure material	Aluminium
Nominal input voltage	100...120 V AC single phase 200...240 V AC single phase
Rated power in W	150 W
Output voltage	24 V DC
Power supply output current	6.25 A

Complementary

Input voltage limits	90...132 V AC 170...264 V AC
Nominal network frequency	50...60 Hz
Network system compatibility	TN TT IT
Maximum leakage current	1 mA 240 V AC
Input protection type	Integrated fuse (not interchangeable) 4 A
Inrush current	35 A at 115 V 70 A at 230 V
Power factor	0.55 at 115 V AC 0.45 at 230 V AC
Efficiency	88.8 % at 230 V AC
Output voltage adjustment	21.6...26.4 V
Power dissipation in W	29 W
Current consumption	< 3.2 A 115 V AC < 1.9 A 230 V AC
Turn-on time	< 500 ms
Holding time	> 20 ms 115 V AC > 40 ms 230 V AC
Startup with capacitive loads	7000 µF
Residual ripple	< 170 mV

Meantime between failure [MTBF]	700000 h at 25 °C, full load conforming to SR 332
Output protection type	Against overload and short-circuits, protection technology: automatic reset Against over temperature, protection technology: manual reset Against overvoltage, protection technology: manual reset
Connections - terminals	Screw connection: 0.75...2.5 mm ² , (AWG 18...AWG 14) without wire end ferrule Screw connection: 0.75...1.5 mm ² , (AWG 18...AWG 16) with wire end ferrule
Line and load regulation	< 0.5 % network 0 to 100 % load at 25 °C < 1 % network full voltage range in line at 25 °C
Status LED	1 LED (green) output voltage
Depth	159 mm
Height	30 mm
Width	97 mm
Net weight	0.36 kg
Output coupling	Parallel Serial
Mounting support	Top hat type TH35-15 rail conforming to IEC 60715 Top hat type TH35-7.5 rail conforming to IEC 60715 Double-profile DIN rail panel mounting
Supply	SELV conforming to EN/IEC 60950-1 SELV conforming to EN/IEC 60204-1 SELV conforming to IEC 60364-4-41
Dielectric strength	3750 V AC with input to output
Service life	10 year(s)

Environment

Standards	EN 62368-1 EN/IEC 61010-1 EN 61010-2-201 EN/IEC 61204-3 EN 61000-6-1 EN 61000-6-2 EN 61000-6-3 EN 61000-6-4 EN 61000-3-2 EN 61000-3-3 UL 62368-1 UL 61010-1 UL 61010-2-201 CSA C22.2 No 62368-1 CSA C22.2 No 61010-1 CSA C22.2 No 61010-2-201 IEC 60335-1 EN/IEC 62368-1
Product certifications	CE CULus EAC RCM CB Scheme KC
Environmental characteristic	3M4 conforming to IEC 60721-3-3
Operating altitude	5000 m
Shock resistance	100 m/s ² for 11 ms
IP degree of protection	IP10
Ambient air temperature for operation	-30...-25 °C with current derating of 4 % per °C mounting position B, G < 2000 m -25...50 °C without derating mounting position B, G < 2000 m 50...70 °C with current derating of 2 % per °C mounting position B, G < 2000 m
Electrical shock protection class	Class I
Pollution degree	2
Vibration resistance	3 mm (f= 2...9 Hz) conforming to IEC 60068-2-6 10 m/s ² (f= 9...200 Hz) conforming to IEC 60068-2-6

Electromagnetic immunity	<p>Immunity to electrostatic discharge - test level: 6 kV (contact discharge) conforming to EN/IEC 61000-4-2</p> <p>Immunity to electrostatic discharge - test level: 9 kV (air discharge) conforming to EN/IEC 61000-4-2</p> <p>Immunity to conducted RF disturbances - test level: 10 V/m (80 MHz...2 GHz) conforming to EN/IEC 61000-4-3</p> <p>Immunity to conducted RF disturbances - test level: 5 V/m (2...2.7 GHz) conforming to EN/IEC 61000-4-3</p> <p>Immunity to conducted RF disturbances - test level: 3 V/m (2.7...6 GHz) conforming to EN/IEC 61000-4-3</p> <p>Immunity to fast transients - test level: 4 kV (on input-output) conforming to EN/IEC 61000-4-4</p> <p>Surge immunity test - test level: 3 kV (between power supply and earth) conforming to EN/IEC 61000-4-5</p> <p>Surge immunity test - test level: 1.5 kV (between phases) conforming to EN/IEC 61000-4-5</p> <p>Immunity to conducted RF disturbances - test level: 10 V (0.15...80 MHz) conforming to EN/IEC 61000-4-6</p> <p>Immunity to magnetic fields - test level: 30 A/m (50...60 Hz) conforming to EN/IEC 61000-4-8</p> <p>Immunity to voltage dips conforming to EN/IEC 61000-4-11</p> <p>Disturbing field emission conforming to EN 55016-2-3</p> <p>Limits for harmonic current emissions conforming to EN 61000-3-2</p> <p>Conducted disturbance emission conforming to EN 55016-1-2</p> <p>Conducted disturbance emission conforming to EN 55016-2-1</p>
---------------------------------	---

Electromagnetic emission	<p>Conducted emissions conforming to EN 61000-6-3</p> <p>Radiated emissions conforming to EN 61000-6-4</p>
---------------------------------	--

Packing Units

Unit Type of Package 1	PCE
Number of Units in Package 1	1
Package 1 Height	4.000 cm
Package 1 Width	14.600 cm
Package 1 Length	21.500 cm
Package 1 Weight	490.000 g
Unit Type of Package 2	S03
Number of Units in Package 2	17
Package 2 Height	30.000 cm
Package 2 Width	30.000 cm
Package 2 Length	40.000 cm
Package 2 Weight	8.849 kg

Offer Sustainability

Sustainable offer status	Green Premium product
REACH Regulation	REACH Declaration
EU RoHS Directive	Pro-active compliance (Product out of EU RoHS legal scope) EU RoHS Declaration
Mercury free	Yes
China RoHS Regulation	China RoHS declaration
RoHS exemption information	Yes
Environmental Disclosure	Product Environmental Profile
Circularity Profile	End of Life Information
WEEE	The product must be disposed on European Union markets following specific waste collection and never end up in rubbish bins
California proposition 65	WARNING: This product can expose you to chemicals including: Lead and lead compounds, which is known to the State of California to cause cancer and birth defects or other reproductive harm. For more information go to www.P65Warnings.ca.gov

Electrical Safety

- If the unit is use in a manner not specified by the manufacturer, the protection provided by the equipment may be impaired.
- For means of disconnection a switch or circuit breaker, located near the product, must be included in the installation. A marking as disconnecting devi
- The device has an internal fuse. The unit is tested and approved with branch circuit protective device up to 20A. This circuit breaker can be used as d
- The power supply is only suitable for audio, video, information, communication, industrial and control equipment.

Dimensions

Front and Side Views

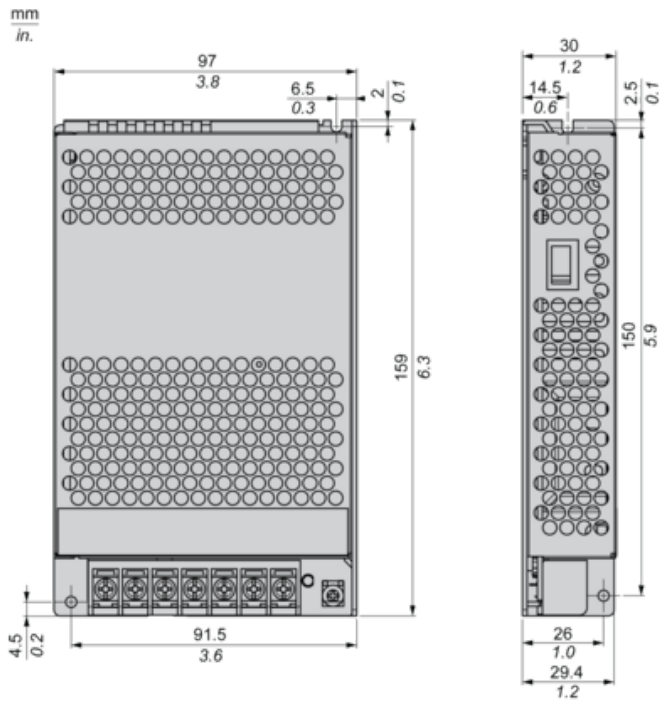

Connections and Schema

Correct Parallel Connection

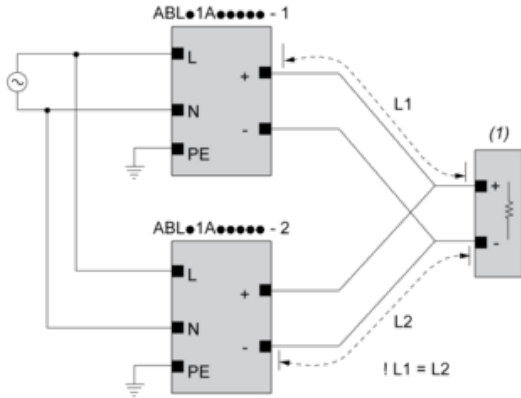

(1) : Load

Incorrect Parallel Connection

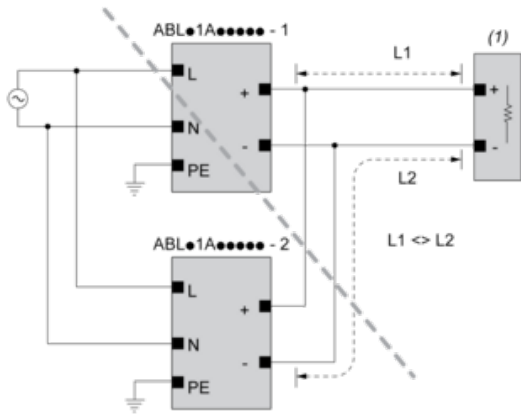

(1) : Load

$ABLx1Axxxxx-1 = ABLx1Axxxxx-2$

max 2 x $ABLx1Axxxxx$

$L1 = L2$

ΔV max 25 mV

$L_{Load} < 90\% \times L_{nom}$

Output Voltage Balancing

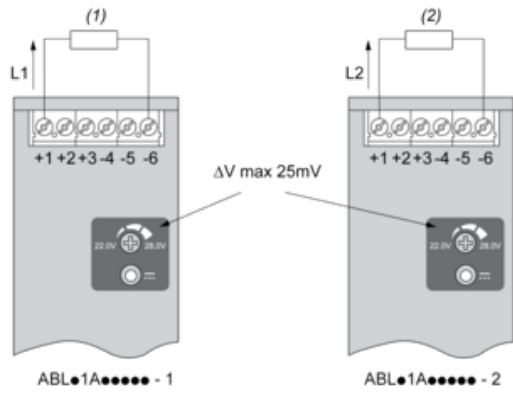

(1) : R_{Load1}

(2) : R_{Load2}

$R_{Load1} = R_{Load2}$

$I_1 = I_2 = \sim I_{nom}$

Series Connection

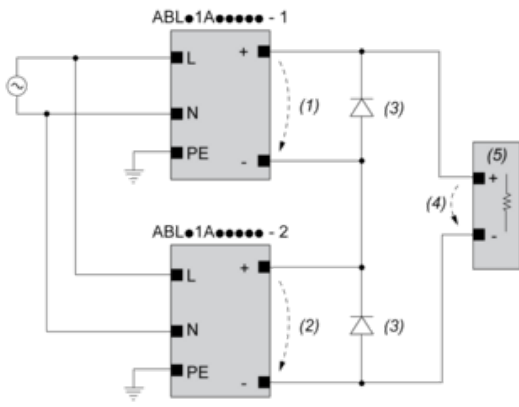

(1) : V_{out1}

(2) : V_{out2}

(3) : 2 x Diode, $V_{RRM} > 2 \times V_{out1/2}$, $I_F > 2 \times I_{nom1/2}$

(4) : $V_{Load} = 2 \times V_{out}$

(5) : Load

Connections and Schema

	(1)		
	<40°C	<50°C	<70°C
ABLP1A12085	60°C	70°C	90°C
ABLP1A24045	60°C	70°C	90°C
ABLP1A24062	60°C	70°C	90°C
ABLP1A24100	60°C	70°C	90°C

(1) : Ambient

Performance Curves

Mounting Position B and G

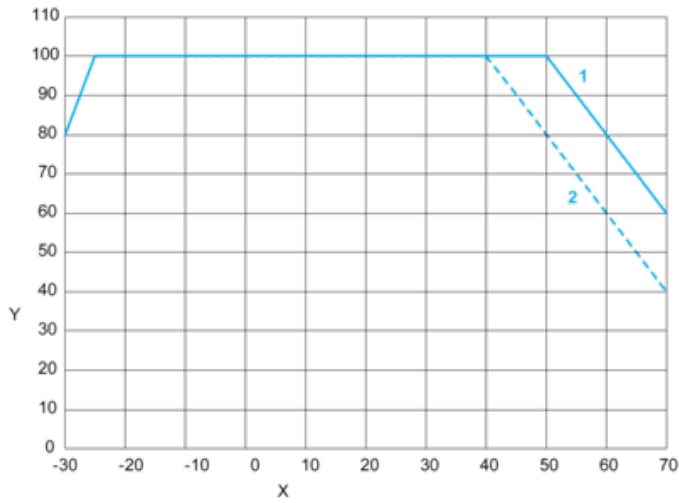

Mounting Position F

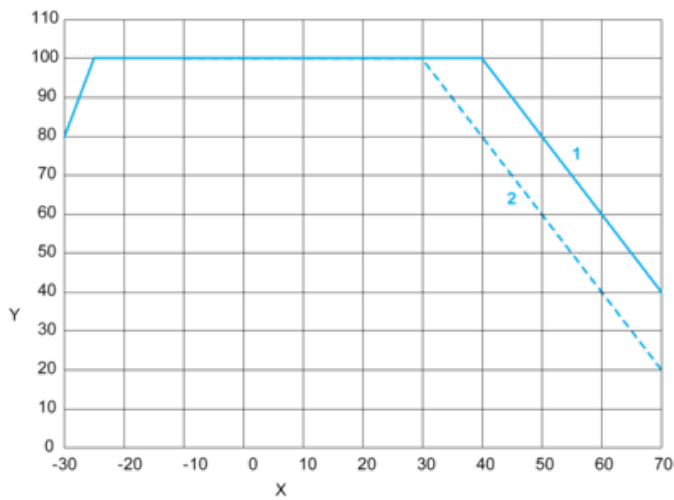

Mounting Position H

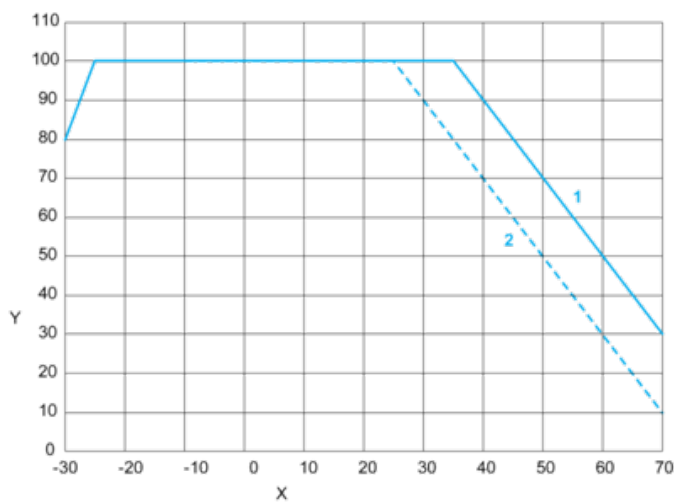

X : Surrounding Air Temperature

Y : Percentage of Max Load (%)

1 : Altitude 2000 m

2 : Altitude 5000 m

Note : < 100 VAC additional derating by 1.33% / VAC

Mounting

Mounting Position B

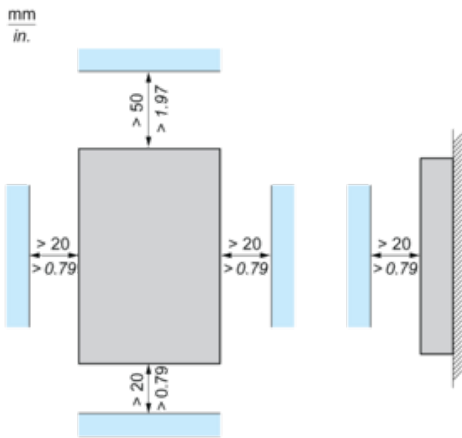

Mounting Position F

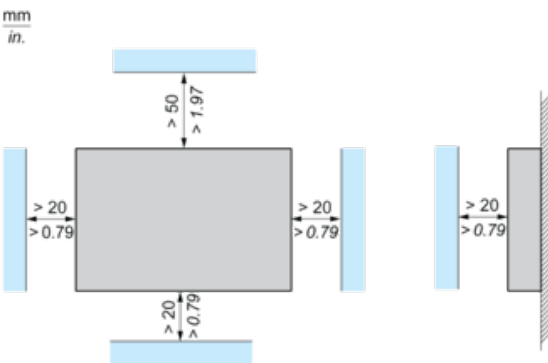

Mounting Position G

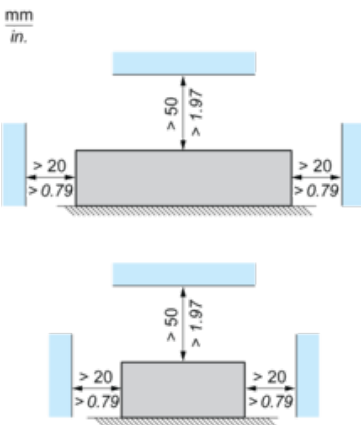

Mounting Position H

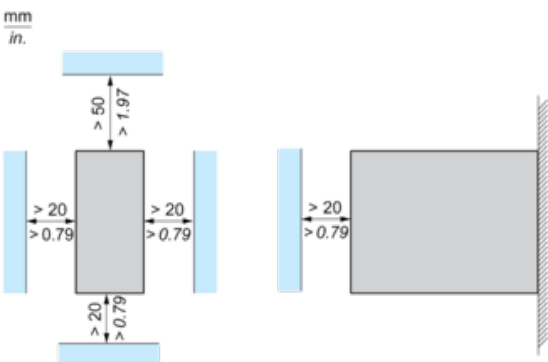

Recommended replacement(s)