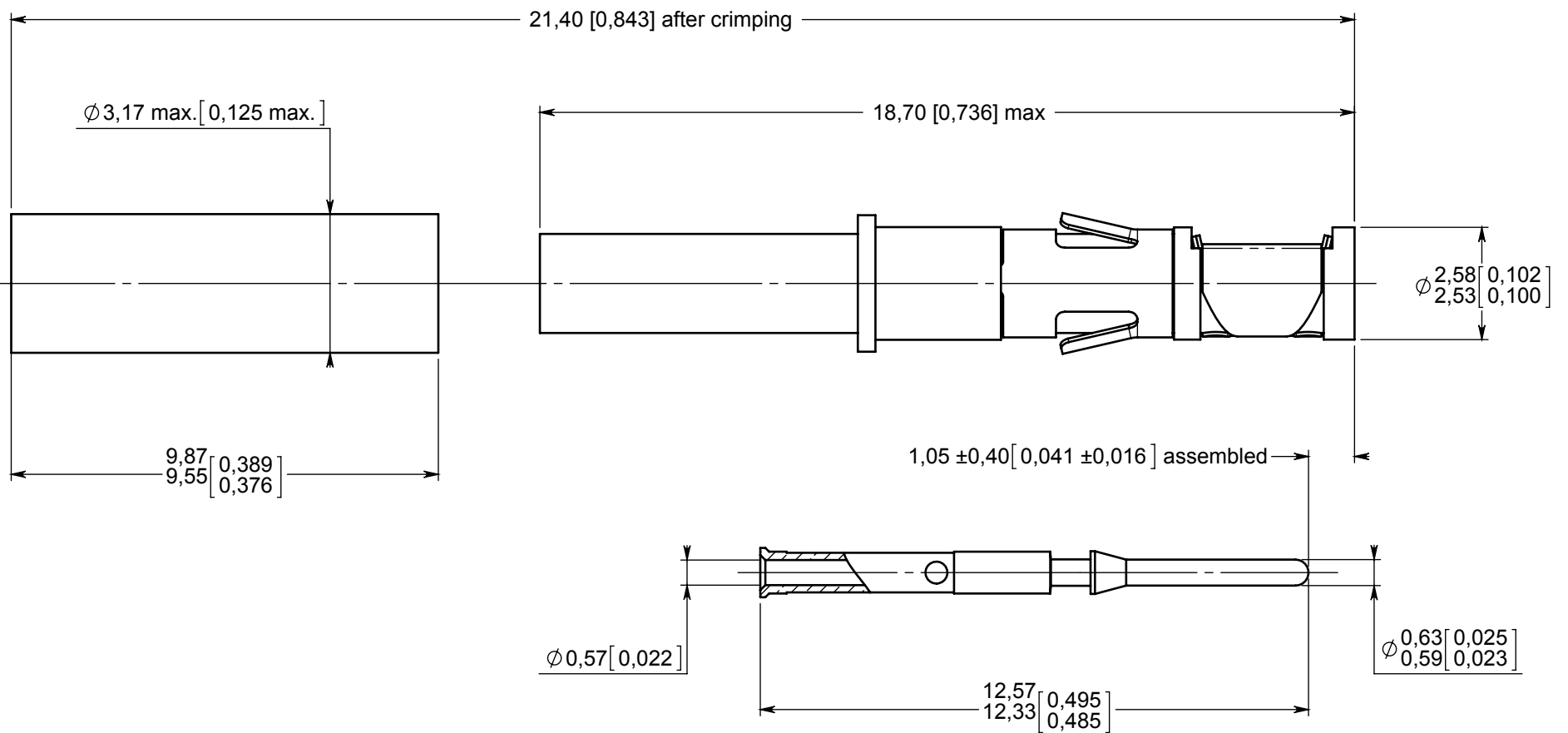

Series
MMC

 SOCKET COAXIAL CONTACT
For KX3A, RG316/U, RG179/U and RG174 cables.

 Issue:
Feb. 11, 2014

 Page
1/1

Materials and finishes :

- Body and center contacts: Copper alloy,
Gold over nickel plated.
- Ferrule and retention clip: Copper alloy, nickel plated.
- Insulator: PTFE.

Extraction tool : 282920

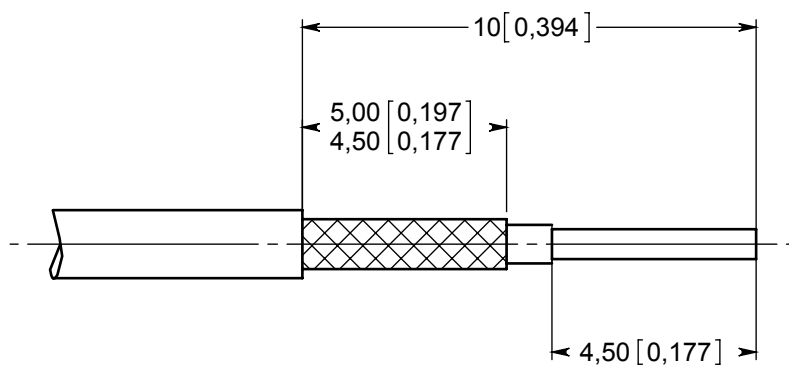
Estimated weight : 0,41 gr. [0.0145 ounces].

Cable strip length :

Mounting instructions:

- Slide ferrule over cable.
- Strip cable as shown.
- Comb the braid.
- Slide the center contact until it butts.
- Crimp the center contact:
 - . Crimping tool: M22520/2-01 (Radiall 282281).
 - Selector: 2 for 50 Ohms cable.
 - Selector: 1 for 75 Ohms cable.
 - . Positioner: M22520/2-04 (Radiall 282981).
- Push the center contact inside the body sub-assembly, until it locks in place.
- Fold back the braid over the body barrel.
- Slide the ferrule until it butts against the shoulder of the body.
- Crimp the ferrule :
 - . Crimping tool: M22520/4-01 (Radiall 282292).
 - . Positioner: M22520/4-02 (Radiall 282973).

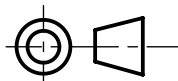
DIMENSIONS : mm (inch are given for information only)



This information is given as an indication. In the continual goal to improve our products, we reserve the right to make any modifications judged necessary.

4112_9311

| | | | | |
|---------------------|-------------|---|-----------|----------|
| CREATION | | | | |
| PEN: | | | | |
| NOM: Caunet G. | | | | |
| DATE: June 23, 1980 | | | | |
| APPR.: | Nov 8, 2011 | Document revised on new supportn - Tittle updated | Perrin H. | L.Garcia |
| | Issue | Revisions | Name | Approved |