

NS 35/15 ZN PERF(18X5,2)2000MM - DIN rail perforated



3240571

<https://www.phoenixcontact.com/in/products/3240571>

Please be informed that the data shown in this PDF document is generated from our Online Catalog. Please find the complete data in the user documentation. Our General Terms of Use for Downloads are valid.



DIN rail perforated, similar to EN 60715, material: Steel, galvanized, Standard profile, color: silver, Hole size: 5.2 mm x 18 mm

Commercial Data

Item number	3240571
Packing unit	25 pc
Minimum order quantity	25 pc
Sales Key	BE7
Product Key	BE7243
Catalog Page	Page 533 (C-3-2019)
GTIN	4046356583145
Weight per Piece (including packing)	1,250 g
Weight per Piece (excluding packing)	1,250 g
Customs tariff number	72166190
Country of origin	DE

NS 35/15 ZN PERF(18X5,2)2000MM - DIN rail perforated

3240571

<https://www.phoenixcontact.com/in/products/3240571>

Technical Data

Product properties

Product type	DIN rail
--------------	----------

Dimensions

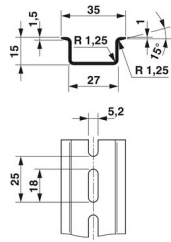
Dimensional drawing	
Width	35 mm
Hole width	18 mm
Height	15 mm
Hole height	5.2 mm
Length	2000 mm
Drill hole spacing	25 mm

Material specifications

Color	silver
Material	Steel
Coating	galvanized

Standards and regulations

Connection in acc. with standard	IEC / EN
Tests	similar to EN 60715

NS 35/15 ZN PERF(18X5,2)2000MM - DIN rail perforated



3240571

<https://www.phoenixcontact.com/in/products/3240571>

Drawings

Dimensional drawing

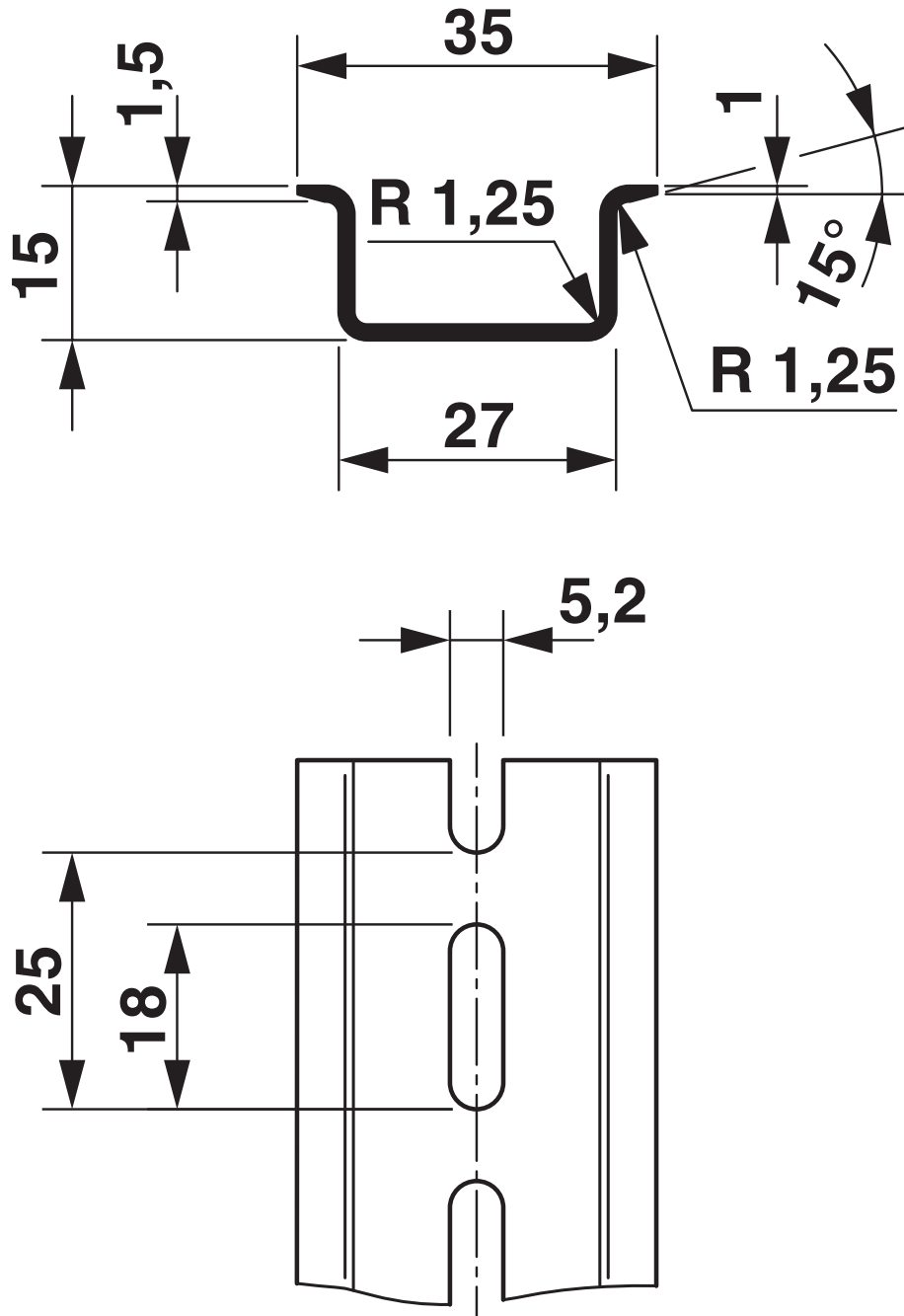

NS 35/15 ZN PERF(18X5,2)2000MM - DIN rail perforated



3240571

<https://www.phoenixcontact.com/in/products/3240571>

Classifications

ECLASS

ECLASS-11.0	27400602
ECLASS-12.0	27400602

ETIM

ETIM 8.0	EC001285
----------	----------

UNSPSC

UNSPSC 21.0	39121700
-------------	----------

NS 35/15 ZN PERF(18X5,2)2000MM - DIN rail perforated



3240571

<https://www.phoenixcontact.com/in/products/3240571>

Environmental Product Compliance

China RoHS	Environmentally friendly use period: unlimited = EFUP-e
	No hazardous substances above threshold values

Phoenix Contact 2023 © - all rights reserved
<https://www.phoenixcontact.com>

PHOENIX CONTACT (I) Pvt. Ltd.
A-58/2, Okhla Industrial Area, Phase - II, New Delhi-110 020

+91.1275.71420
info@phoenixcontact.co.in