

# QUINT-PS/3AC/48DC/20 - Power supply unit



2320827

<https://www.phoenixcontact.com/in/products/2320827>

Please be informed that the data shown in this PDF document is generated from our Online Catalog. Please find the complete data in the user documentation. Our General Terms of Use for Downloads are valid.



Primary-switched power supply unit QUINT POWER, Screw connection, DIN rail mounting, SFB Technology (Selective Fuse Breaking), input: 3-phase, output: 48 V DC / 20 A

## Product Description

QUINT POWER power supplies with maximum functionality

QUINT POWER circuit breakers magnetically and therefore quickly trip at six times the nominal current, for selective and therefore cost-effective system protection. The high level of system availability is additionally ensured, thanks to preventive function monitoring, as it reports critical operating states before errors occur.

Reliable starting of heavy loads takes place via the static power reserve POWER BOOST. Thanks to the adjustable voltage, all ranges between 5 V DC ... 56 V DC are covered.

## Your advantages

- Adjustable output voltage of 30 to 56 V DC
- Reliable starting of difficult loads with the static POWER BOOST power reserve with up to 1.5 times the nominal current permanently
- Fast tripping of standard circuit breakers with dynamic power reserve SFB (selective fuse breaking) technology with up to 6 times the nominal current for 12 ms
- Preventive function monitoring indicates critical operating states before errors occur

## Commercial Data

Item number	2320827
Packing unit	1 pc
Minimum order quantity	1 pc
Sales Key	CMP
Product Key	CMPQ34
Catalog Page	Page 244 (C-4-2019)
GTIN	4046356547734
Weight per Piece (including packing)	2,912.1 g
Weight per Piece (excluding packing)	2,500 g
Customs tariff number	85044083
Country of origin	TH

## Technical Data

### Input data

#### AC operation

Nominal input voltage range	3x 400 V AC ... 500 V AC
Input voltage range	3x 320 V AC ... 575 V AC
	2x 360 V AC ... 575 V AC
	450 V DC ... 800 V DC
Voltage type of supply voltage	AC/DC
Inrush current	< 20 A (typical)
Inrush current integral ( $I^2t$ )	< 1 A <sup>2</sup> s
AC frequency range	45 Hz ... 65 Hz
Frequency range DC	0 Hz
Mains buffering time	typ. 25 ms (400 V AC)
	typ. 35 ms (500 V AC)
Current consumption	3x 2.1 A (400 V AC)
	3x 1.7 A (500 V AC)
	1.7 A (600 V DC)
Nominal power consumption	1386 VA
Protective circuit	Transient surge protection; Varistor
Typical response time	< 1 s
Permissible backup fuse	B6 B10 B16 AC:
Permissible DC backup fuse	DC: Connect a suitable fuse upstream
Recommended breaker for input protection	6 A ... 16 A (AC: Characteristics B, C, D, K)
Discharge current to PE	< 3.5 mA

### Output data

Efficiency	> 93 % (at 400 V AC and nominal values)
Nominal output voltage	48 V DC $\pm$ 1 %
Setting range of the output voltage ( $U_{Set}$ )	30 V DC ... 56 V DC (> 48 V DC, constant capacity restricted)
Nominal output current ( $I_N$ )	20 A (-25 °C ... 60 °C, $U_{OUT}$ = 48 V DC)
POWER BOOST ( $I_{Boost}$ )	22.5 A (-25 °C ... 40 °C permanent, $U_{OUT}$ = 48 V DC)
Selective Fuse Breaking ( $I_{SFB}$ )	100 A (12 ms)
Magnetic circuit breaker tripping	B2 / B4 / B6 / B10 / C2 / C4 / C6
Derating	60 °C ... 70 °C (2.5%/K)
Feedback voltage resistance	max. 60 V DC
Protection against overvoltage at the output (OVP)	< 60 V DC
Active current limitation	Approx. $I_{BOOST}$ = 22.5 A (for short-circuit)
Control deviation	< 1 % (change in load, static 10 % ... 90 %)
	< 4 % (change in load, dynamic 10 % ... 90 %)
	< 0.1 % (change in input voltage $\pm$ 10 %)
Residual ripple	< 50 mV <sub>PP</sub> (with nominal values)
Output power	960 W

# QUINT-PS/3AC/48DC/20 - Power supply unit



2320827

<https://www.phoenixcontact.com/in/products/2320827>

Maximum no-load power dissipation	24 W
Power loss nominal load max.	70 W
Rise time	< 0.5 ms ( $U_{OUT}$ (10 % ... 90 %))
Connection in parallel	yes, for redundancy and increased capacity
Connection in series	yes

Signal: DC OK active

Output description	$U_{OUT} > 0.9 \times U_N$ : High signal
Switching voltage range	18 V DC ... 24 V DC
Maximum inrush current	$\leq 20$ mA (short-circuit-proof)
Continuous load current	$\leq 20$ mA

Signal: DC OK floating

Output description	Relay contact, $U_{OUT} > 0.9 \times U_N$ : Contact closed
Maximum switching voltage	30 V AC/DC
	24 V DC
Maximum inrush current	0.5 A
	1 A
Continuous load current	$\leq 1$ A

Signal: POWER BOOST, active

Output description	$I_{OUT} < I_N$ : High signal
Switching voltage range	18 V DC ... 24 V DC
Output voltage	+ 48 V DC
Maximum inrush current	$\leq 20$ mA (short-circuit-proof)
Continuous load current	$\leq 20$ mA

## Connection data

Input

Connection method	Screw connection
Conductor cross section, rigid min.	0.2 mm <sup>2</sup>
Conductor cross section, rigid max.	6 mm <sup>2</sup>
Conductor cross section flexible min.	0.2 mm <sup>2</sup>
Conductor cross section flexible max.	4 mm <sup>2</sup>
Conductor cross section AWG min.	18
Conductor cross section AWG max.	10
Stripping length	7 mm
Screw thread	M3
Tightening torque, min	0.5 Nm
Tightening torque max	0.6 Nm

Output

Connection method	Screw connection
Conductor cross section, rigid min.	0.5 mm <sup>2</sup>
Conductor cross section, rigid max.	16 mm <sup>2</sup>

# QUINT-PS/3AC/48DC/20 - Power supply unit



2320827

<https://www.phoenixcontact.com/in/products/2320827>

Conductor cross section flexible min.	0.5 mm <sup>2</sup>
Conductor cross section flexible max.	16 mm <sup>2</sup>
Conductor cross section AWG min.	8
Conductor cross section AWG max.	6
Stripping length	10 mm
Screw thread	M3
Tightening torque, min	1.2 Nm
Tightening torque max	1.5 Nm

## Signal

Connection method	Screw connection
Conductor cross section, rigid min.	0.2 mm <sup>2</sup>
Conductor cross section, rigid max.	6 mm <sup>2</sup>
Conductor cross section flexible min.	0.2 mm <sup>2</sup>
Conductor cross section flexible max.	4 mm <sup>2</sup>
Conductor cross section AWG min.	18
Conductor cross section AWG max.	10
Screw thread	M3
Tightening torque, min	0.5 Nm
Tightening torque max	0.6 Nm

## Signaling

Types of signaling	LED
	Active switching output
	Relay contact

### Signal output: DC OK active

Status display	$U_{OUT} > 0.9 \times U_N$ : "DC OK" LED green
Note on status display	$U_{OUT} < 0.9 \times U_N$ : Flashing "DC OK" LED
	$I_{OUT} < I_N$ : LED ON

### Signal output: DC OK floating

Status display	$U_{OUT} > 0.9 \times U_N$ : "DC OK" LED green
Note on status display	$U_{OUT} < 0.9 \times U_N$ : Flashing "DC OK" LED

### Signal output: POWER BOOST, active

Status display	$I_{OUT} > I_N$ : LED "BOOST" yellow
----------------	--------------------------------------

## Electrical properties

Number of phases	3.00
Insulation voltage input/output	4 kV AC (type test)
	2 kV AC (routine test)
Insulation voltage output / PE	500 V DC (routine test)
Insulation voltage input / PE	3.5 kV AC (type test)
	2 kV AC (routine test)

# QUINT-PS/3AC/48DC/20 - Power supply unit



2320827

<https://www.phoenixcontact.com/in/products/2320827>

## Product properties

Product type	Power supply
Product family	QUINT POWER
MTBF (IEC 61709, SN 29500)	> 890000 h (25 °C)
	> 509000 h (40 °C)

## Insulation characteristics

Protection class	I
Degree of pollution	2

## Dimensions

Width	96 mm
Height	130 mm
Depth	179 mm

## Alternative assembly

Width	176 mm
Height	130 mm
Depth	99 mm

## Mounting

Mounting type	DIN rail mounting
Assembly instructions	alignable: $P_N \geq 50\%$ , 5 mm horizontally, 15 mm next to active components, 50 mm vertically alignable: $P_N < 50\%$ , 0 mm horizontally, 40 mm vertically top, 20 mm vertically bottom
Mounting position	horizontal DIN rail NS 35, EN 60715
With protective coating	No

## Material specifications

Housing material	Metal
Type of housing	Steel sheet, zinc-plated
Housing material	Steel sheet, zinc-plated

## Environmental and real-life conditions

### Ambient conditions

Degree of protection	IP20
Ambient temperature (operation)	-25 °C ... 70 °C (> 60 °C Derating: 2,5 %/K)
Ambient temperature (storage/transport)	-40 °C ... 85 °C
Ambient temperature (start-up type tested)	-40 °C
Maximum altitude	4000 m
Climatic class	3K3 (in acc. with EN 60721)
Max. permissible relative humidity (operation)	≤ 95 % (at 25 °C, non-condensing)
Shock	18 ms, 30g, in each space direction (according to IEC 60068-2-27)

# QUINT-PS/3AC/48DC/20 - Power supply unit



2320827

<https://www.phoenixcontact.com/in/products/2320827>

Vibration (operation)	< 15 Hz, amplitude $\pm 2.5$ mm (according to IEC 60068-2-6)
	15 Hz ... 150 Hz, 2.3g, 90 min.

## Standards and regulations

Rail applications	EN 50121-4
	EN 50121-3-2
Standard – Limitation of mains harmonic currents	EN 61000-3-2
Standard - Electrical safety	IEC 61010-2-201 (SELV)
Standard - Equipment safety	BG (design tested)
Standard - Approval for medical use	IEC 60601-1, 2 x MOOP
Standard – Protection against shock currents, basic requirements for protective separation in electrical equipment	EN 50178
Standard – Safety extra-low voltage	IEC 61010-1 (SELV)
	IEC 61010-2-201 (PELV)
Standard - Safe isolation	IEC 61010-2-201
Standard - safety for equipment for measurement, control, and laboratory use	IEC 61010-1
Standard - Safety of transformers	IEC 61558-2-17

## Overvoltage category

EN 62477-1	III
------------	-----

## Approvals

CSA	CAN/CSA-C22.2 No. 60950-1-07
	CSA-C22.2 No. 107.1-01
UL approvals	UL Listed UL 508
	UL/C-UL Recognized UL 60950-1 (3-wire + PE, star net)
	UL ANSI/ISA-12.12.01 Class I, Division 2, Groups A, B, C, D (Hazardous Location)

## EMC data

Low Voltage Directive	Conformance with Low Voltage Directive 2014/35/EC
EMC requirements for noise emission	EN 61000-6-3
	EN 61000-6-4
EMC requirements for noise immunity	EN 61000-6-1
	EN 61000-6-2
Electromagnetic compatibility	Conformance with EMC Directive 2014/30/EU

## Electrostatic discharge

Standards/regulations	EN 61000-4-2
-----------------------	--------------

## Electrostatic discharge

Contact discharge	8 kV (Test Level 4)
Discharge in air	15 kV (Test Level 4)
Comments	Criterion A

## Electromagnetic HF field

# QUINT-PS/3AC/48DC/20 - Power supply unit



2320827

<https://www.phoenixcontact.com/in/products/2320827>

Standards/regulations	EN 61000-4-3
-----------------------	--------------

## Electromagnetic HF field

Frequency range	80 MHz ... 1 GHz
Test field strength	20 V/m (Test Level 3)
Frequency range	1 GHz ... 2 GHz
Test field strength	10 V/m (Test Level 3)
Frequency range	2 GHz ... 3 GHz
Test field strength	10 V/m (Test Level 3)
Comments	Criterion A

## Fast transients (burst)

Standards/regulations	EN 61000-4-4
-----------------------	--------------

## Fast transients (burst)

Input	4 kV (Test Level 4 - asymmetrical)
Output	2 kV (Test Level 3 - asymmetrical)
Signal	2 kV (Test Level 4 - asymmetrical)
Comments	Criterion A

## Surge voltage load (surge)

Standards/regulations	EN 61000-4-5
Input	2 kV (Test Level 3 - symmetrical)
	6 kV (Test Level 4 - asymmetrical)
Output	1 kV (Test Level 2 - symmetrical)
	2 kV (Test Level 3 - asymmetrical)
Signal	1 kV (Test Level 2 - asymmetrical)
Comments	Criterion A

## Conducted interference

Standards/regulations	EN 61000-4-6
-----------------------	--------------

## Conducted interference

I/O/S	asymmetrical
Frequency range	0.15 MHz ... 80 MHz
Comments	Criterion A
Voltage	10 V (Test Level 3)

## Criteria

Criterion A	Normal operating behavior within the specified limits.
Criterion B	Temporary impairment to operational behavior that is corrected by the device itself.

# QUINT-PS/3AC/48DC/20 - Power supply unit



2320827

<https://www.phoenixcontact.com/in/products/2320827>

## Drawings

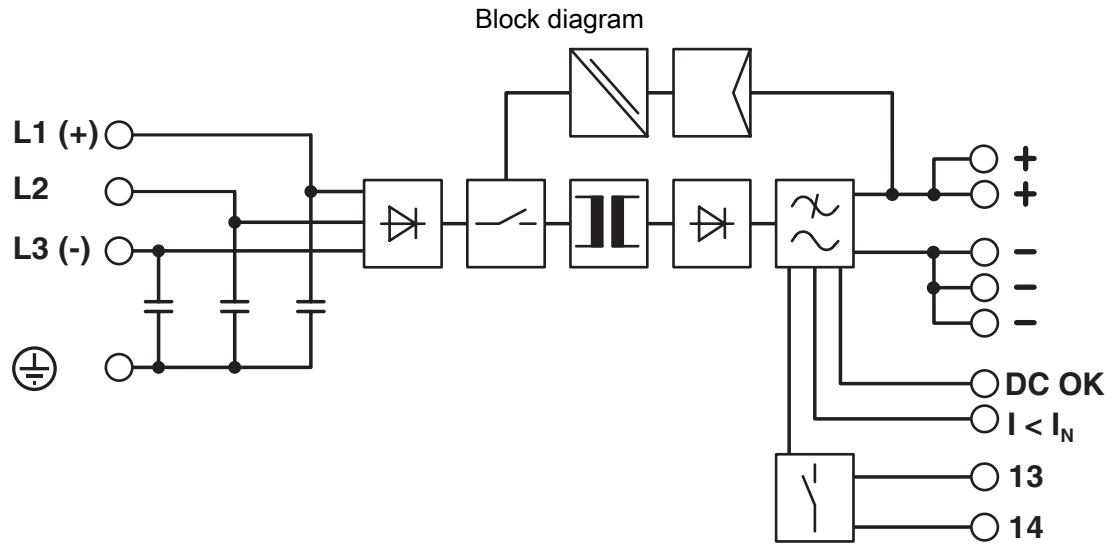



# QUINT-PS/3AC/48DC/20 - Power supply unit



2320827

<https://www.phoenixcontact.com/in/products/2320827>

## Approvals



**cUL Recognized**  
Approval ID: FILE E 211944



**UL Recognized**  
Approval ID: FILE E 211944



**IECEE CB Scheme**  
Approval ID: SI-2899



**EAC**  
Approval ID: EAC-Zulassung



**EAC**  
Approval ID: EAC-Zulassung



**UL Listed**  
Approval ID: FILE E 123528



**cUL Listed**  
Approval ID: FILE E 123528



**Type approved**  
Approval ID: 005-006



**EAC**  
Approval ID: RU S-DE.BL08.W.00764



**UL Recognized**  
Approval ID: FILE E 211944



**IECEE CB Scheme**  
Approval ID: SI-2899



**cUL Recognized**  
Approval ID: FILE E 211944

# QUINT-PS/3AC/48DC/20 - Power supply unit



2320827

<https://www.phoenixcontact.com/in/products/2320827>



**cUL Listed**

Approval ID: FILE E 123528



**UL Listed**

Approval ID: FILE E 123528



**Type approved**

Approval ID: 005-006



**EAC**

Approval ID: RU S-DE.BL08.W.00764



**EAC**

Approval ID: RU S-DE.BL08.W.00764



**EAC**

Approval ID: RU S-DE.BL08.W.00764



**cUL Listed**

Approval ID: FILE E 199827



**UL Listed**

Approval ID: FILE E 199827



**UL Listed**

Approval ID: FILE E 199827



**cUL Listed**

Approval ID: FILE E 199827

# QUINT-PS/3AC/48DC/20 - Power supply unit



2320827

<https://www.phoenixcontact.com/in/products/2320827>

## Classifications

### ECLASS

ECLASS-11.0	27040701
ECLASS-13.0	27040701
ECLASS-12.0	27040701

### ETIM

ETIM 8.0	EC002540
----------	----------

### UNSPSC

UNSPSC 21.0	39121000
-------------	----------

# QUINT-PS/3AC/48DC/20 - Power supply unit



2320827

<https://www.phoenixcontact.com/in/products/2320827>

## Environmental Product Compliance

REACH SVHC	Lead 7439-92-1
China RoHS	Environmentally Friendly Use Period = 25;
	For information on hazardous substances, refer to the manufacturer's declaration available under "Downloads"

# QUINT-PS/3AC/48DC/20 - Power supply unit



2320827

<https://www.phoenixcontact.com/in/products/2320827>

## Accessories

### UTA 107 - DIN rail adapter

2853983

<https://www.phoenixcontact.com/in/products/2853983>

Universal DIN rail adapter, for screwing on switchgear



---

### UWA 182/52 - Mounting adapter

2938235

<https://www.phoenixcontact.com/in/products/2938235>

Universal wall adapter for securely mounting the device in the event of strong vibrations. The device is screwed directly onto the mounting surface. The universal wall adapter is attached on the top/bottom.



# QUINT-PS/3AC/48DC/20 - Power supply unit

2320827

<https://www.phoenixcontact.com/in/products/2320827>



## QUINT-DIODE/48DC/2X20/1X40 - Redundancy module

2320160

<https://www.phoenixcontact.com/in/products/2320160>



DIN rail diode module 48 V DC/2x20 A or 1x40 A. Uniform redundancy up to the consumer.

---

## TRIO-DIODE/48DC/2X10/1X20 - Redundancy module

2866527

<https://www.phoenixcontact.com/in/products/2866527>



Redundancy module with function monitoring, 48 V DC, 2x 10 A, 1x 20 A

# QUINT-PS/3AC/48DC/20 - Power supply unit



2320827

<https://www.phoenixcontact.com/in/products/2320827>

## CB TM1 1A SFB P - Thermomagnetic device circuit breaker

2800836

<https://www.phoenixcontact.com/in/products/2800836>



Thermomagnetic device circuit breaker, 1-pos., tripping characteristic SFB, 1 changeover contact, plug for base element.

---

## CB TM1 2A SFB P - Thermomagnetic device circuit breaker

2800837

<https://www.phoenixcontact.com/in/products/2800837>



Thermomagnetic device circuit breaker, 1-pos., tripping characteristic SFB, 1 changeover contact, plug for base element.

# QUINT-PS/3AC/48DC/20 - Power supply unit



2320827

<https://www.phoenixcontact.com/in/products/2320827>

## CB TM1 3A SFB P - Thermomagnetic device circuit breaker

2800838

<https://www.phoenixcontact.com/in/products/2800838>



Thermomagnetic device circuit breaker, 1-pos., tripping characteristic SFB, 1 changeover contact, plug for base element.

---

## CB TM1 4A SFB P - Thermomagnetic device circuit breaker

2800839

<https://www.phoenixcontact.com/in/products/2800839>



Thermomagnetic device circuit breaker, 1-pos., tripping characteristic SFB, 1 changeover contact, plug for base element.



# QUINT-PS/3AC/48DC/20 - Power supply unit



2320827

<https://www.phoenixcontact.com/in/products/2320827>

## CB TM1 5A SFB P - Thermomagnetic device circuit breaker

2800840

<https://www.phoenixcontact.com/in/products/2800840>



Thermomagnetic device circuit breaker, 1-pos., tripping characteristic SFB, 1 changeover contact, plug for base element.

---

## CB TM1 6A SFB P - Thermomagnetic device circuit breaker

2800841

<https://www.phoenixcontact.com/in/products/2800841>



Thermomagnetic device circuit breaker, 1-pos., tripping characteristic SFB, 1 changeover contact, plug for base element.

# QUINT-PS/3AC/48DC/20 - Power supply unit



2320827

<https://www.phoenixcontact.com/in/products/2320827>

## CB TM1 8A SFB P - Thermomagnetic device circuit breaker

2800842

<https://www.phoenixcontact.com/in/products/2800842>



Thermomagnetic device circuit breaker, 1-pos., tripping characteristic SFB, 1 changeover contact, plug for base element.

---

## CB TM1 10A SFB P - Thermomagnetic device circuit breaker

2800843

<https://www.phoenixcontact.com/in/products/2800843>



Thermomagnetic device circuit breaker, 1-pos., tripping characteristic SFB, 1 changeover contact, plug for base element.

# QUINT-PS/3AC/48DC/20 - Power supply unit



2320827

<https://www.phoenixcontact.com/in/products/2320827>

## PLT-SEC-T3-3S-230-FM - Type 3 surge protection device

2905230

<https://www.phoenixcontact.com/in/products/2905230>

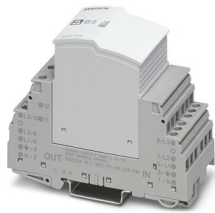

Plug-in device protection, according to type 3/class III, for 3-phase power supply networks with separate N and PE (5-conductor system: L1, L2, L3, N, PE), with integrated surge-proof fuse and remote indication contact.

---

## PLT-SEC-T3-60-FM-UT - Type 3 surge protection device

2907917

<https://www.phoenixcontact.com/in/products/2907917>



Type 3 surge protection, consisting of protective plug and base element, with integrated status indicator and remote signaling for single-phase power supply networks. Nominal voltage: 60 V AC/DC

---

Phoenix Contact 2023 © - all rights reserved  
<https://www.phoenixcontact.com>

PHOENIX CONTACT (I) Pvt. Ltd.  
A-58/2, Okhla Industrial Area, Phase - II, New Delhi-110 020

+91.1275.71420  
[info@phoenixcontact.co.in](mailto:info@phoenixcontact.co.in)