

Product datasheet

Specifications



beacon with buzzer + 1 illuminated unit - Ø 45 mm - 24 V AC/DC

XVMB2RSSB

! Discontinued on: 19 January 2022

! End-of-service on: 03 June 2022

! Discontinued

Main

Range of product	Harmony XVM
Product or component type	Pre-assembled and pre-cabled beacon
Beacon or indicator bank unit type	1 illuminated unit
Component name	XVM
Light source	Red super bright LED with BA 15d base steady signalling
Light block color	Red
[Us] rated supply voltage	24 V AC/DC
Indicator bank base type	Base with integrated buzzer
Mounting mode	Vertical

Complementary

Kit composition	Aluminium support tube Base unit Metal bracket Cover
Mounting diameter	45 mm
Connections - terminals	Flying leads, clamping capacity: 1 x 0.325 mm ² (AWG 22)
Marking	CE
Mounting support	Aluminium tube
Short-circuit protection	0.2 A
[Ui] rated insulation voltage	250 V conforming to IEC 60947-1
Nominal voltage limit	0.85...1.1 Un conforming to IEC 60947-5-1
Current consumption	18 mA on base unit 20 mA on flash discharge tube unit
[Uimp] rated impulse withstand voltage	4 kV conforming to IEC 60947-1
Flashing frequency	0.8 Hz
Fundamental frequency	4 kHz
Net weight	0.221 kg

Environment

IP degree of protection	IP42 vertical position conforming to IEC 60529
Product certifications	CCC
Standards	EN/IEC 60947-1 EN/IEC 60947-5-1
Ambient air temperature for storage	-25...70 °C
Ambient air temperature for operation	-10...50 °C
Overvoltage category	Class I conforming to IEC 60947-1 Class I conforming to IEC 60947-5-1 Class I conforming to IEC 61140
Protective treatment	TC
Noise level	0...80 dB at 1 m

Packing Units

Unit Type of Package 1	PCE
Number of Units in Package 1	1
Package 1 Height	6 cm
Package 1 Width	8 cm
Package 1 Length	5.4 cm
Package 1 Weight	466 g
Unit Type of Package 2	S04
Number of Units in Package 2	20
Package 2 Height	30 cm
Package 2 Width	40 cm
Package 2 Length	60 cm
Package 2 Weight	10.393 kg
Unit Type of Package 3	P06
Number of Units in Package 3	80
Package 3 Height	75 cm
Package 3 Width	40 cm
Package 3 Length	80 cm
Package 3 Weight	62.28 kg

Offer Sustainability

Sustainable offer status	Green Premium product
REACH Regulation	REACH Declaration
EU RoHS Directive	Pro-active compliance (Product out of EU RoHS legal scope) EU RoHS Declaration
Mercury free	Yes
China RoHS Regulation	China RoHS declaration
RoHS exemption information	Yes
Environmental Disclosure	Product Environmental Profile
WEEE	The product must be disposed on European Union markets following specific waste collection and never end up in rubbish bins

Contractual warranty

Warranty

18 months

Pre-Assembled and Pre-Cabled Tower Light with Fixing Base for Mounting on Vertical Support (Support Tube + Metal Bracket)

Dimensions

Below drawing shows the maximum configuration of the product. Select the number of stages according to the product characteristics in order to get **b2** dimension.

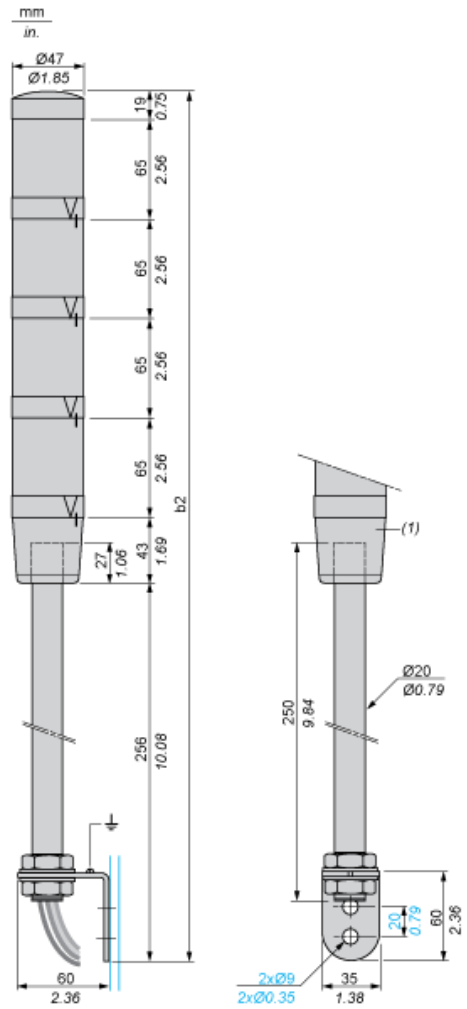

(1) Base unit with or without buzzer.

Number of illuminated units	b2 in mm	b2 in in.
1 unit	383	15.08
2 units	448	17.64
3 units	513	20.20
4 units	578	22.76

Pre-Assembled and Pre-Cabled Tower Light

Wire Colors

4th illuminated unit: yellow wire

3rd illuminated unit: green wire

2nd illuminated unit: white wire

1st illuminated unit: blue wire

Common: black wire

Buzzer (if integrated in base unit): grey wire

Base Unit with Integral Buzzer

Adjustment of Audible Signal

View from above:

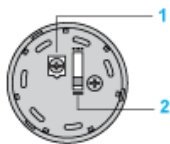

- (1) Volume adjustment potentiometer: 0 to 85 dB. Use either a cross headed or flat tipped screwdriver.
- (2) 2-position selector for type of audible signal: continuous tone or intermittent tone

Recommended replacement(s)