

Product data sheet

Specifications



Configurable receiver, Harmony XB5R, 4 PNP, 2 buttons, 6 indicating LEDs, monostable, 24V DC

ZBRRC

Main

Range of product	Harmony
Product or component type	Programmable receiver
Device short name	ZBRRC
Product specific application	Interface to PLC
Function of module	Monostable
Reset time	2 ms time delay
Transmission frequency	2405 MHz
Emission class	5M00G7W
Antenna type	Omnidirectional

Complementary

Output type	Transistor PNP
Output contacts	4 PNP
Time delay range	0.5 s (tolerance: - 15...15 %)
Maximum switching current	0.2 mA DC
Minimum switching current	10 mA at 5 V DC
[Us] rated supply voltage	24 V DC - 15...20 %
Maximum voltage drop	<2 V DC at 2 A
Communication port protocol	Zigbee green power at 2.4 GHz conforming to IEEE 802.15.4
Maximum sensing distance	100 m in free field 25 m transmitter in a plastic box type XAL D and receiver in a metal enclosure 40 m transmitter in box type XAL D, receiver in metal enclosure and use relay-antenna
Response time	< 30 ms after transmitter clicks
Utilisation category	DC-13 conforming to EN/IEC 60947-5-1
Maximum power consumption in VA	20 VA DC
Maximum power consumption in W	20 W DC
Breaking capacity	4.8 W (per output)
Short-circuit protection	0.4 A fuse type fast blow
Operating position	Any position without derating

Electrical connection	1 conductor cable 0.14...2.5 mm ² - AWG 26...AWG 14 - solid - without cable end conforming to IEC 60947-1 2 conductors cable 0.14...1.5 mm ² - AWG 26...AWG 16 - solid - without cable end conforming to IEC 60947-1 1 conductor cable 0.14...4 mm ² - AWG 26...AWG 12 - flexible - with cable end conforming to IEC 60947-1 2 conductors cable 0.14...1.5 mm ² - AWG 26...AWG 16 - flexible - with cable end conforming to IEC 60947-1
Tightening torque	0.5...1 N.m conforming to EN/IEC 60947-1
Housing material	Self-extinguishing plastic
Status LED	1 LED green for power ON 1 LED green and yellow for reception signal 4 LEDs green for relay ON
Mounting support	35 mm symmetrical DIN rail conforming to EN/IEC 60715 Mounting plate
Rated short-duration power frequency withstand voltage	1 kV 50 Hz conforming to EN/IEC 60947-5-1
[Uimp] rated impulse withstand voltage	0.8 kV
Surge withstand	0.5 kV differential mode conforming to IEC 61000-4-5 1 kV common mode conforming to IEC 61000-4-5
Max power consumption in W	1 mW
Number of channels	1
Modulation Technique	O-QPSK
Bandwidth	5 MHz
Antenna gain	0 dBi
Width	36 mm
Height	108 mm
Depth	75 mm
Net weight	0.13 kg
Environment	
Standards	EN/IEC 60947-5-1
Radio agreement	RSS SRRC ANATEL ARIB T66 FCC ICASA
Product certifications	CCC CSA GOST C-Tick UL
Marking	CE
Ambient air temperature for storage	-40...70 °C
Relative humidity	90 % at -20...55 °C, without condensation conforming to ETSI EN 300 440-1
Vibration resistance	+/- 7.5 mm (f= 5...14 Hz) conforming to IEC 60068-2-6 2 gn (f= 8...150 Hz) conforming to IEC 60068-2-6
Shock resistance	10 gn (duration = 16 ms) for 6000 shocks conforming to IEC 60068-2-27
IP degree of protection	IP20 (casing) conforming to IEC 60529 IP20 (terminals)
Pollution degree	2 conforming to IEC 60664-1
Overvoltage category	III conforming to IEC 60664-1
Insulation resistance	> 500 MOhm at 500 V DC conforming to NF C 20-030
[Ui] rated insulation voltage	60 V conforming to IEC 60664-1

Electromagnetic compatibility	<p>Immunity for industrial environments conforming to EN/IEC 61000-6-2</p> <p>Conducted and radiated emissions class B conforming to CISPR 22</p> <p>Electrostatic discharge immunity test - test level: 8 kV (in free air (in insulating parts)) conforming to IEC 61000-4-2</p> <p>Electrostatic discharge immunity test - test level: 6 kV (on contact (on metal parts)) conforming to IEC 61000-4-2</p> <p>Susceptibility to electromagnetic fields - test level: 10 V/m (80...2000 MHz) conforming to IEC 61000-4-3</p> <p>Susceptibility to electromagnetic fields - test level: 3 V/m (80...2700 MHz, distance = 20 m) conforming to IEC 61000-4-3</p> <p>Electrical fast transient/burst immunity test - test level: 2 kV (power supply wires) conforming to IEC 61000-4-4</p> <p>Conducted RF disturbances - test level: 10 V conforming to IEC 61000-4-6</p> <p>Radiated emission conforming to ETSI EN 300 440-1</p> <p>Conducted emission conforming to EN 300-489-1</p> <p>Conducted emission conforming to ETSI EN 300 489-3</p> <p>Radiated emission conforming to ETSI EN 300 440-2</p> <p>Electrical fast transient/burst immunity test - test level: 1 kV (PNP output wires) conforming to IEC 61000-4-4</p> <p>1.2/50 µs shock waves immunity test - test level: 0.5 kV (differential mode) conforming to IEC 61000-4-5</p> <p>1.2/50 µs shock waves immunity test - test level: 1 kV (common mode) conforming to IEC 61000-4-5</p> <p>Immunity to microbreaks and voltage drops - test level: 7 ms conforming to IEC 61000-4-11</p>
--------------------------------------	---------------------------------------------------------------------------------------------------------------------------------------------------------------------------------------------------------------------------------------------------------------------------------------------------------------------------------------------------------------------------------------------------------------------------------------------------------------------------------------------------------------------------------------------------------------------------------------------------------------------------------------------------------------------------------------------------------------------------------------------------------------------------------------------------------------------------------------------------------------------------------------------------------------------------------------------------------------------------------------------------------------------------------------------------------------------------------------------------------------------------------------------------------------------------------------------------------------------------------------------------------------------------------------------------------------------------------------------------------------------------------------------------------------------------------------------------------------------------------------------------------------------------------------------------------

Packing Units

Unit Type of Package 1	PCE
Number of Units in Package 1	1
Package 1 Height	4.6 cm
Package 1 Width	7.9 cm
Package 1 Length	9.6 cm
Package 1 Weight	122.0 g
Unit Type of Package 2	S03
Number of Units in Package 2	64
Package 2 Height	30.0 cm
Package 2 Width	30.0 cm
Package 2 Length	40.0 cm
Package 2 Weight	8.498 kg

Offer Sustainability

EU RoHS Directive	Pro-active compliance (Product out of EU RoHS legal scope) EU RoHS Declaration
Mercury free	Yes
China RoHS Regulation	China RoHS declaration
RoHS exemption information	Yes
Environmental Disclosure	Product Environmental Profile
Circularity Profile	End of Life Information
WEEE	The product must be disposed on European Union markets following specific waste collection and never end up in rubbish bins
California proposition 65	WARNING: This product can expose you to chemicals including: Nickel compounds, which is known to the State of California to cause cancer, and Di-isodecyl phthalate (DIDP), which is known to the State of California to cause birth defects or other reproductive harm. For more information go to www.P65Warnings.ca.gov

Contractual warranty

Warranty	18 months
-----------------	-----------

Programmable Receiver

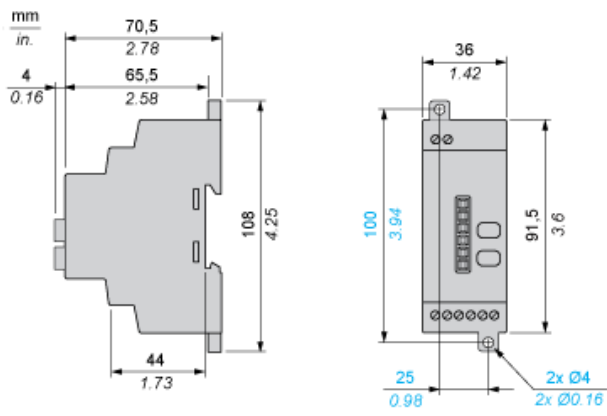

Receiver Clearance

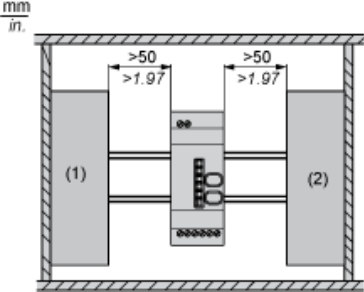

- (1) Drive
- (2) Power Supply or PLC

Receiver Mounting

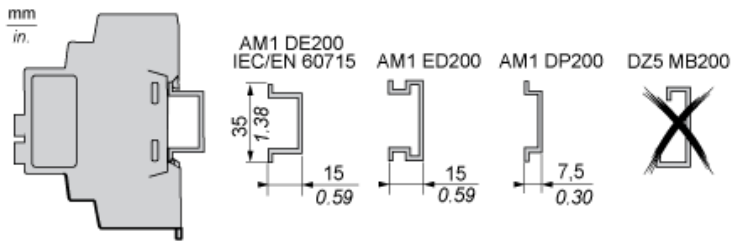

Programmable Receiver

Wiring Diagram

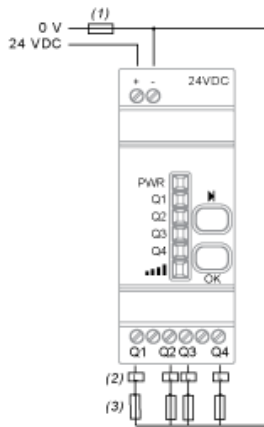

- (1) 400 mA fast-blow fuse
- (2) $I_{max} = 200 \text{ mA}$
- (3) $I_{max} = 300 \text{ mA}$

Dimensions

mm
in.

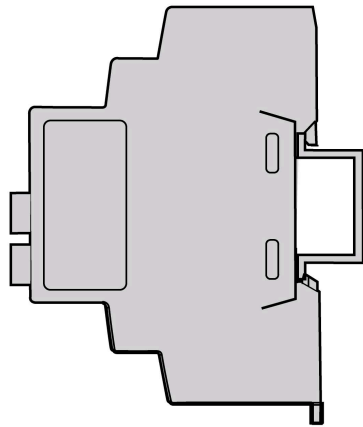
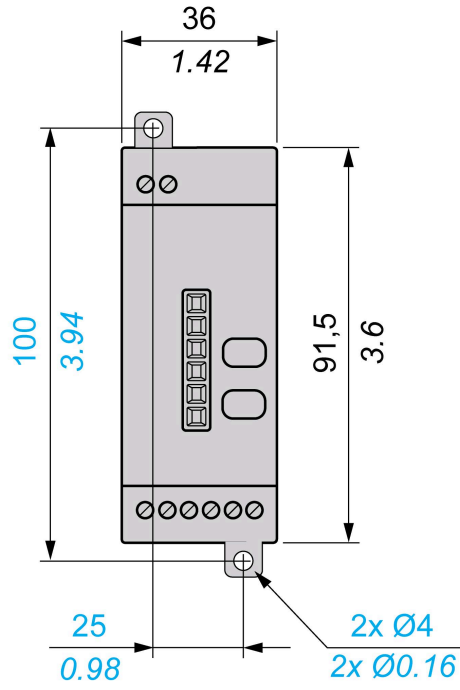
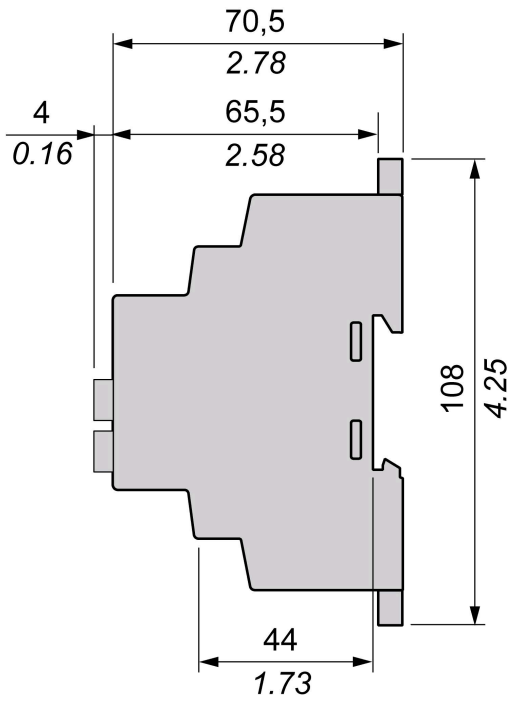

AM1 DE200
IEC/EN 60715

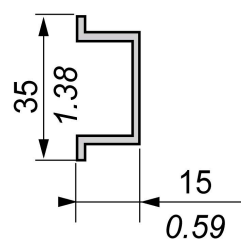

AM1 ED200

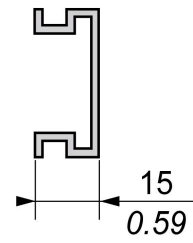

AM1 DP200

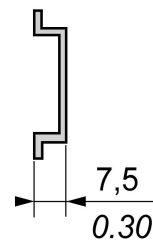

DZ5 MB200

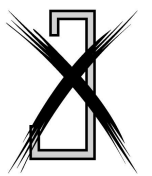

Wiring Diagram

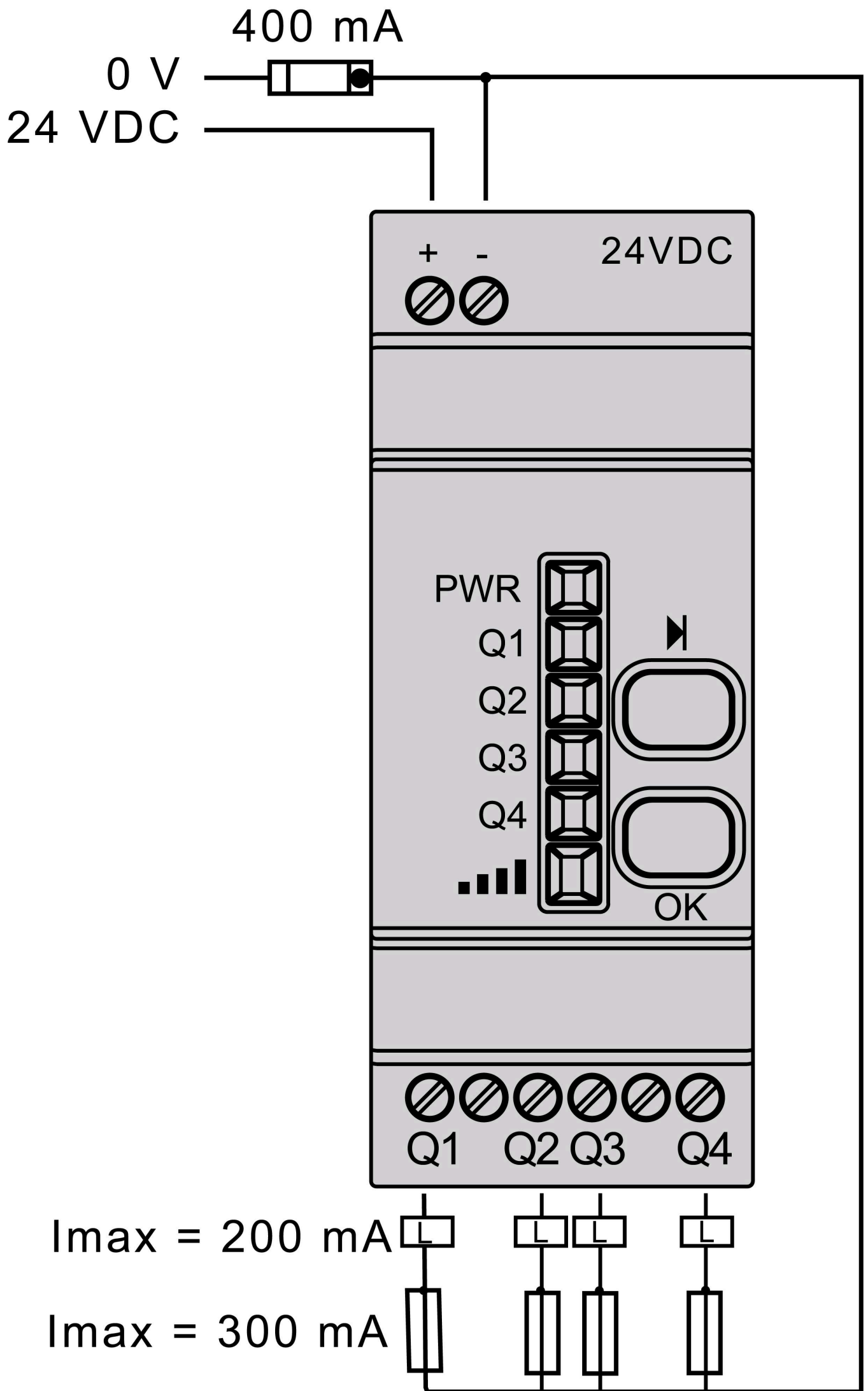

Recommended replacement(s)