

Series
EPX

POWER CRIMP PIN CONTACT
FOR SIZE 5 CAVITY.
FOR AWG 8 & 10 CABLES.

Issue:
Nov. 15, 2013

Page
1/1

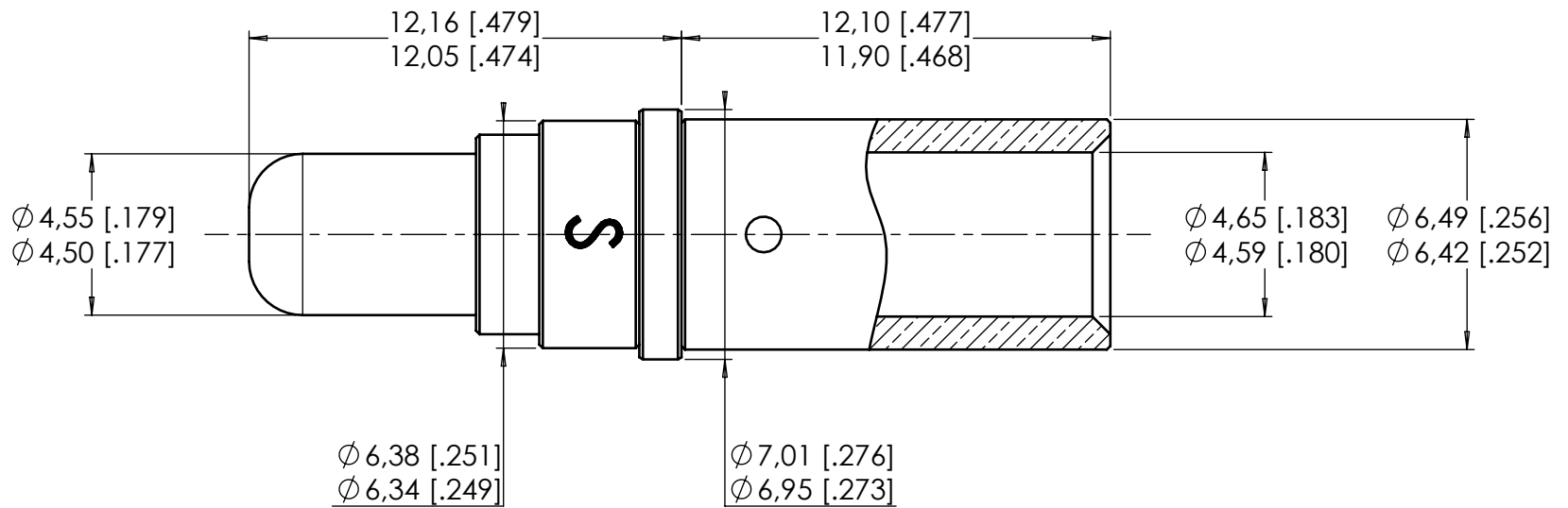

Cable stripped length:

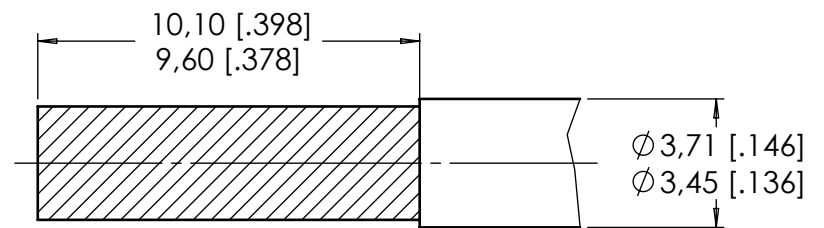

Material and finish: copper alloy, gold over nickel plated.

Crimping Tool: M22520/23-01.

Die set: M22520/23-2.

Locator: RADIALL P/N 282557020.

Extraction tool: M81969/28-01 - RADIALL P/N 282946.

Note:

In order to ensure the SAE AS39029 tensile strength requirements for any wire plating, RADIALL recommend to use MS3348-8-10 bushing when crimped to AWG 10 cable.

DIMENSIONS : mm (inch are given for information only)

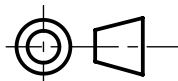

Estimated weight : 4,35 g

CREATION				
PEN: M92041				
NOM: J.P. Macari				
DATE: Jun. 16, 1992				
APPR.:				
	Nov. 15, 2013	TDS updated + Bushing use recommendation for AWG 10 cables added.	MONTIER A.	LE GLOAHEC Y.
	Aug. 23, 2013	"S" Engraving added.	M.Pessard	L.Garcia
	Jan. 24, 2013	Redrawn. Modif. of cable stripped length.	L.Garcia	G.Motteau
		5,76/5,70 was 5,60/5,40.		
	Issue	Revisions	Name	Approved

This document contains proprietary information and such information shall not be disclosed to any third party for any purpose whatsoever or used for manufacturing purposes without prior written agreement from RADIALL. This information is given as an indication. In the continual goal to improve our products, we reserve the right to make any modifications judged necessary.

4112_9311