

PRODUCT DESCRIPTION CODE :

10141272-111 LF

- RoHS COMPLIANT, LEAD FREE
- UNREELING DIRECTION, SEE NOTE 5 :
BLANK = DIRECTION 1
"A" = DIRECTION 2 (ON REQUEST)
- FOR CUSTOMER CODE :
BLANK = GENERAL USE
V = CUSTOMER DEDICATED PART
- APPLICABLE AWG, SEE NOTE 1
- PLATING :
1 = 3µm MIN MATTE TIN (CONTACT AREA)
3 = 0.76µm MIN GOLD (CONTACT AREA)
ALL OVER 1.27µm MIN Ni UNDERLAYER

PRODUCT NO	WIRE SIZE	DIM "A"	DIM "B"	DIM "C"	DIM "D"
10141272-111LF	AWG 22	1.9	1.9	1.7	1.75
10141272-112LF	AWG 26-28	1.9	1.8	1.6	1.25
10141272-113LF	AWG 24	1.9	1.9	1.7	1.55

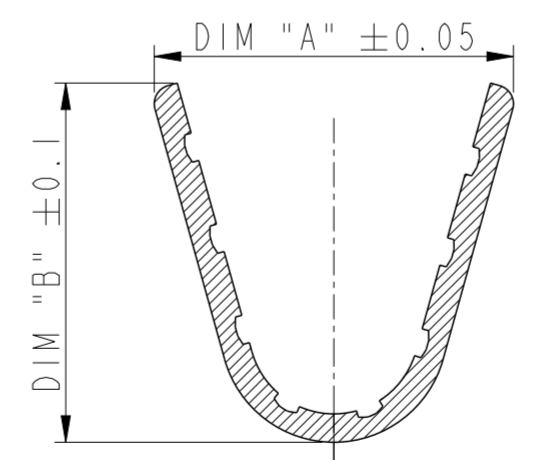
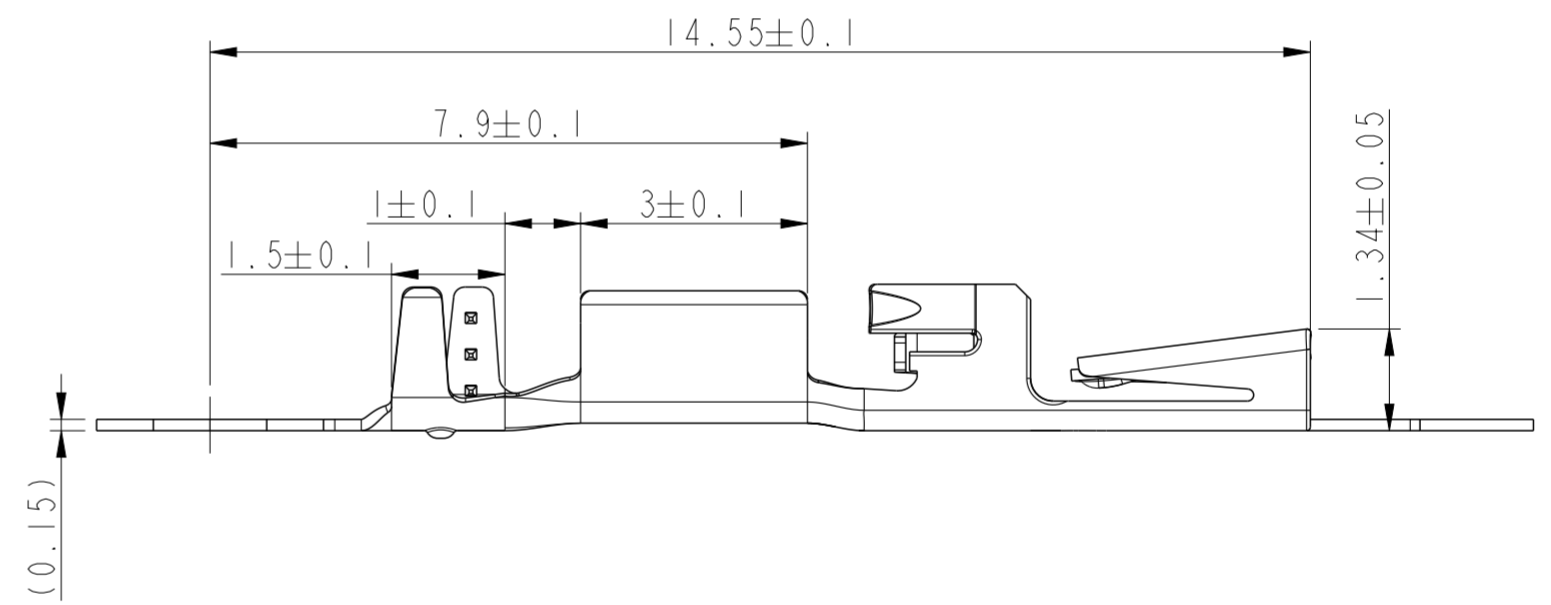
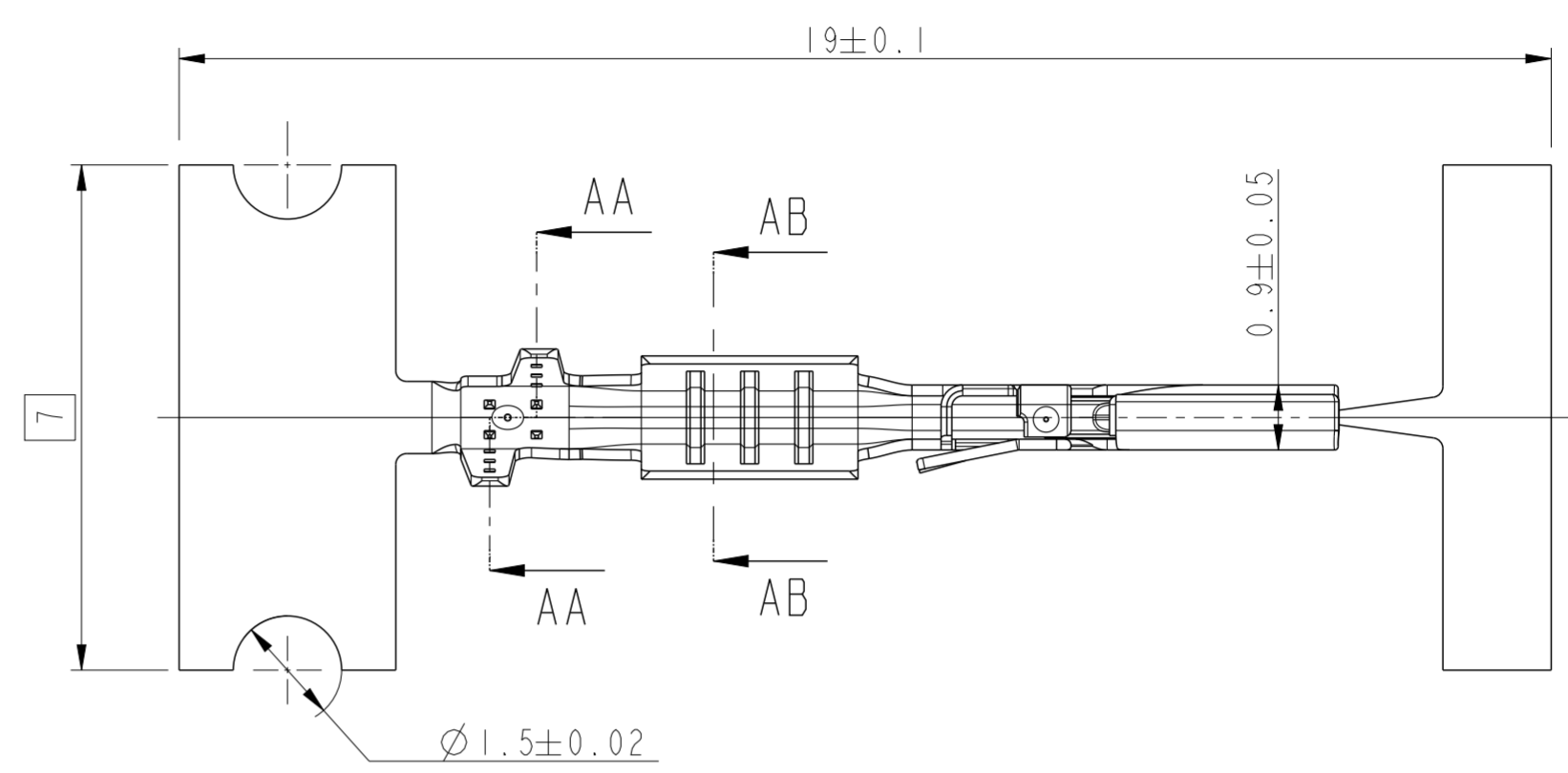

SECTION AA-AA
SCALE 25:1

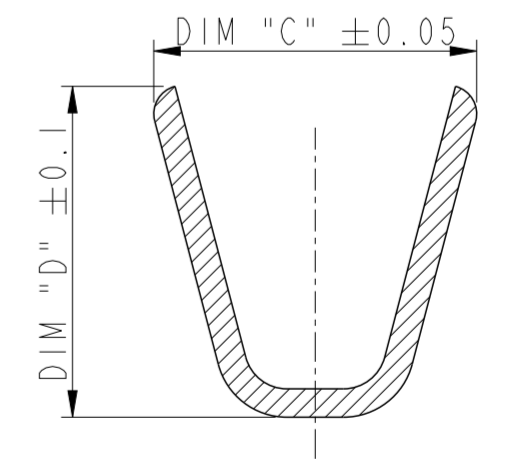

SECTION AB-AB
SCALE 25:1

NOTES

- 1 - APPLICABLE AWG
1- AWG #22
2- AWG #26-28
3- AWG #24
- 2 - PRODUCT SPECIFICATION : GS-12-1422
- 3 - APPLICATION SPECIFICATION AS PER GS-20-0513
- 4 - PACKAGING : 15.000 PCS/REEL
- 5 - UNREELING DIRECTION :
-DIRECTION 1 FOR PN FINISHING BY -LF
-DIRECTION 2 FOR PN FINISHING BY -ALF
- 6 - RoHS COMPATIBLE PRODUCT SPECIFICATIONS
a - LABELLING :
MEETS PACKAGING SPECS AS PER GS-14-920
b - LEGAL STATEMENT :
SEE GS-47-0004.

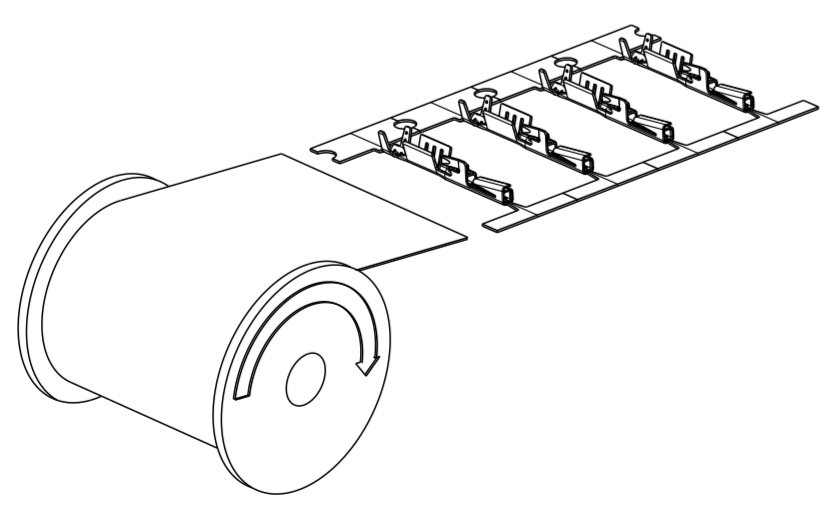

UNREELING DIRECTION 1

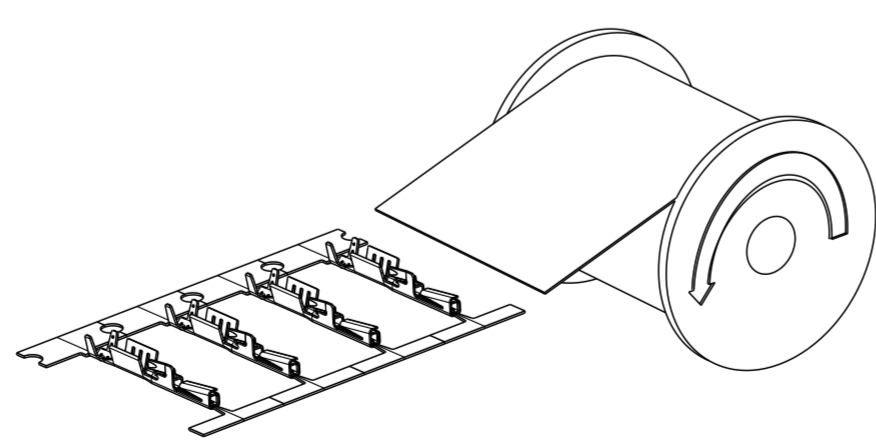

UNREELING DIRECTION 2 (ON REQUEST)

spec ref	GS-12-1422	dr	Sawanth, Ambaa	2017/07/06	projection	mm	size	A2	scale	10:1	
tolerance std	ISO 406 ISO 1101	eng	Cyril Jeune	2019/08/23		mm	ecn no	ELX-F-34657-1			
TOLERANCES UNLESS OTHERWISE SPECIFIED		chr	Hyppias, Arnaud	2019/08/23				rel level	Released		
surface	linear	0.X	±0.1		product family	-	dwg no	10141272			
		0.XX	±0.05		RECEPTACLE TERMINAL	Product - Customer Drw		sheet 1 of 1	rev	D	
	angular	0°	±2°							cat. no.	-