

Series
DSX

SIZE 20HD CRIMP PIN CONTACT
WIRE SIZE AWG 20-22-24
COMPLIANT TO M39029/11-145

Issue:
Dec. 03, 2013

Page
1/1

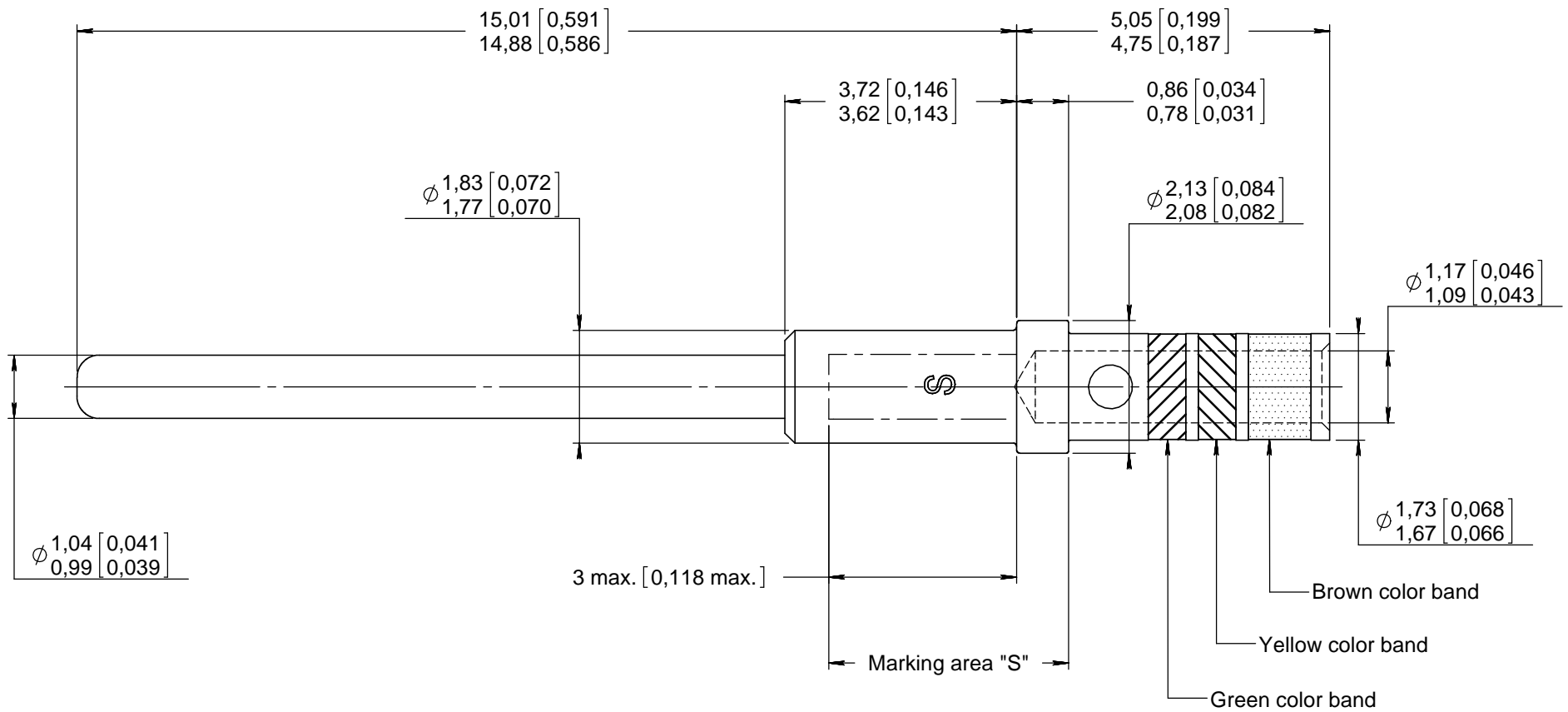
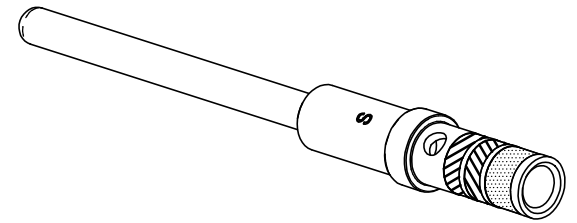

MATERIAL AND FINISHES :
BODY CONTACT : COPPER ALLOY HEAT TREATED HARDNESS 200 HV MAXI
BARREL ANNEALED HARDNESS 60-80 HV

FINISH : GOLD PER MIL-G-45204 TYPE I OR II GRADE C OR D CLASS 1 50 MICROINCHES OVER NICKEL PLATE PER QQ-N-290

WIRES ACCOMODATED : AWG 20-22-24
INSULATOR DIAMETER : .071 MAX (1,80)
STRIP LENGHT : .158 (4,00)

TOOLING
CRIMPING TOOL : M22520/2-01 (RADIALL 282 281)
SELECTOR POSITION : 7 FOR AWG 20
6 FOR AWG 22
5 FOR AWG 24
POSITIONER : M22520/2-08 (RADIALL 282 971)

INSERTION/EXTRACTION TOOL : M81969/1-02 (RADIALL 282 886)
SPL RADIALL INS. 282 881 / EXT. 282 891

DIMENSIONS : mm (inch are given for information only)

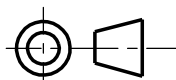

Estimated weight : 0.23 g

This document contains proprietary information and such information shall not be disclosed to any third party for any purpose whatsoever or used for manufacturing purposes without prior written agreement from RADIALL. This information is given as an indication in the continual goal to improve our products, we reserve the right to make any modifications judged necessary.

4112_9311

CREATION PEN: / NOM: FALETTI DATE: Mar. 22, 1985 APPR.: /				
	Dec. 03, 13	Add M39029/11-145 in the title	Moutault	Dupuis
	07/31/08	REDRAWN	VALGRESY	/
	Issue	Revisions	Name	Approved