

Series
EPX

SIZE 22 REAR RELEASE REAR REMOVABLE CRIMP PIN CONTACT
FOR AWG 22, 24 AND 26 CABLES

Issue:
Feb. 12, 2014

Page
1/1

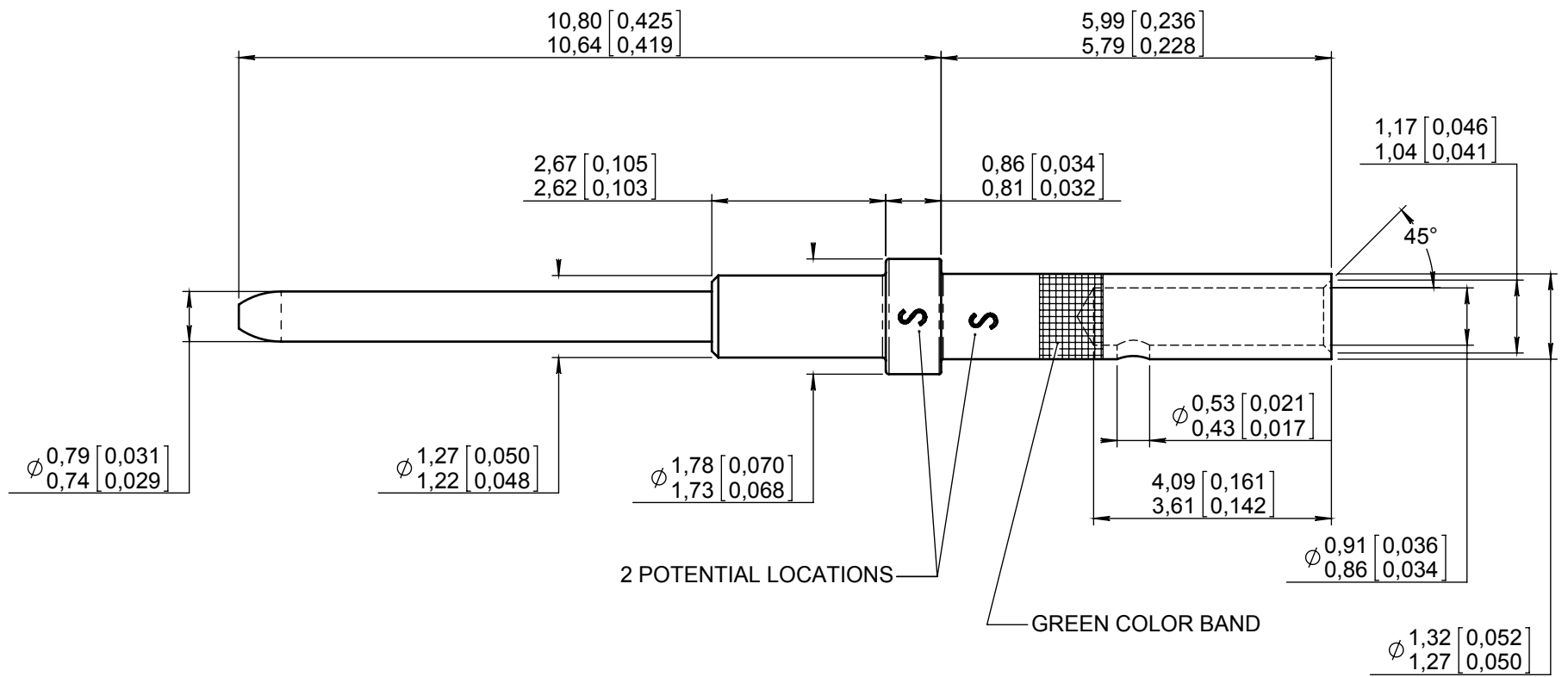

MATERIAL : COPPER ALLOY HARDNESS IN KNOOP 120 MAX (107 HV) FOR CRIMP BARREL
180 MIN (165 HV) FOR BEYOND SHOULDER

FINISH : GOLD PER MIL-G-45204 TYPE I OR II GRADE C OR D CLASS 1 50 MICRINCHES OVER NICKEL PLATE PER QQ-N-290

WIRES ACCOMODATED : AWG 22-24-26
INSULATOR DIAMETER : .055 MAX (1,40)
STRIP LENGHT : .138 (3,50)

CRIMP CONTACT TENSILE REQUIREMENTS USING MIL SPEC TOOLING AND WIRE SPEC
M22520/2-01 22 GA. 11 LBS (5,5 daN)

CRIMPED CONTACTS WILL SHOW NO CRACK WHEN INSPECTED PER MIL-C-22520 AT 10X

RADIALL TOOLING RECOMMENDATION
CRIMPING TOOL : M22520/2-01 (RADIALL 282 281)
SELECTOR POSITION : 4 FOR AWG 22
3 FOR AWG 24
3 FOR AWG 26

POSITIONER : M22520/2-23 (RADIALL 282 970)

INSERTION/EXTRACTION TOOL : M81969/14-01 (RADIALL 282 522)

DIMENSIONS : mm (inch) are given for information only

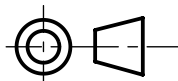

Estimated weight : 0,15 g

CREATION				
PEN:				
NOM: MACARI JP.	Feb. 12, 2014	Insertion/extraction tool P/N updated.	MONTIER A.	LEGLOAHEC Y.
DATE: Nov 01, 86	Jan 04, 13	Barrel lenght corrected. 5,79/5,99 was 5,84/6,03	VIEIRA	LEGLOAHEC
APPR.:	Nov 28, 06	Redrawn and dimensions modified	PAILOT N	DUPUIS
	Issue	Revisions	Name	Approved