

AHSP P/N	LENGTH "A"
NDYYYYF-0001	1000±15MM
NDYYYYF-0002	2000±15MM
NDYYYYF-0004	1500±15MM
NDYYYYF-0005	2500±15MM <sup>8</sup>
NDYYYYF-0007	1750±15MM
NDYYYYF-0006	500±15MM
NDYYYYF-0016	750±20MM
NDYYYYF-0017	1250±30MM
NDYYYYF-0015	DO NOT USE <sup>9</sup>
NDYYYYF-0003	3000±15MM <sup>8</sup>
NDYYYYF-0018	1800±15MM
NDYYYYF-0019	2200±15MM <sup>8</sup>

ZONE	REV.	ECN NUMBER	DESCRIPTION	BY	DATE	APPROVED
	L	ALII-22072401	C DRAWING REVISION MATCHES TO P DRAWING REVISION.	D.YU	07/25/2022	A.LI
	M	DDYR-22082201	ADDED NEW P/N -0018&-0019 TO TABLE 1.	D.DAI	08/26/2022	L.SPEAR
	N	ALII-22121401	REVISED THE NOTE OF P/N NDYYYYF-0015 ON TABLE 1.ADDED NOTE 9.	D.YU	12/16/2022	A.LI

NOTE: ONLY THREE MOST RECENT RELEASED REVISIONS DISPLAYED

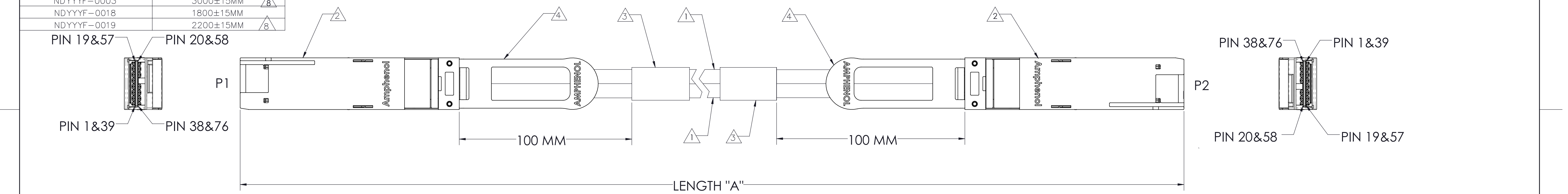

ITEM No.	DESCRIPTION
<sup>1</sup>	30 AWG, 8-PR (Ø6.73), SPLITTER, PVC JKT, VW1
<sup>2</sup>	PLUG, QSFP-DD, REFERENCE "QSFP-DD MSA"
<sup>3</sup>	LABEL, WRAPPED - AHSP P/N, REV, DATE CODE, LENGTH, CoO, SERIAL NUMBER & WEEE LOGO AND CE LOGO
<sup>4</sup>	PULL TAB, BLUE 2718
5	EEPROM - REFERENCE CMIS, PAGE A0 ONLY

- NOTES:
- THIS DRAWING IS RESERVED FOR AMPHENOL.
  - ASSEMBLIES SHALL BE COMPLIANT TO QSFP-DD MSA SPECIFICATION.
  - CABLE ASSEMBLIES, COMPONENTS AND SUB-COMPONENTS SHALL BE COMPLIANT TO EU DIRECTIVE 2011/65/EU-RoHS2.
  - CABLE ASSEMBLIES MUST MEET SHIELDING EFFECTIVENESS REQUIREMENTS OF 35DB MINIMUM FROM 1-10GHZ AND 30DB FROM 10-18 GHZ.
  - DELETED.
  - PACKAGE COMPLETED ASSY IN AN APPROPRIATELY SIZED ESD BAG.
  - UL LABEL MUST BE ON SHIPPING CARTON PER SUBJECT 764 OF THE UL COMPONENT WIRING HARNESS (ZPFW2) FILE #E86140. CSA LABEL MUST BE ON SHIPPING CARTON.

- LENGTHS ABOVE 2.0M DOES NOT SUPPORT IEEE802.3cd.
- PN NDYYYYF-0015 IS DOCUMENTED ON CUSTOM PRINT P/C-NDYYYYF-0015

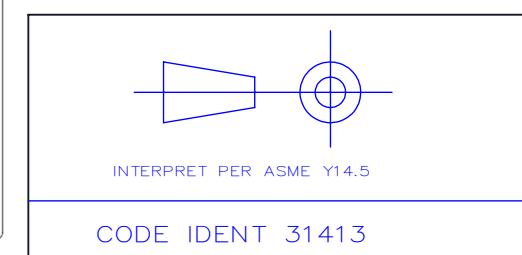
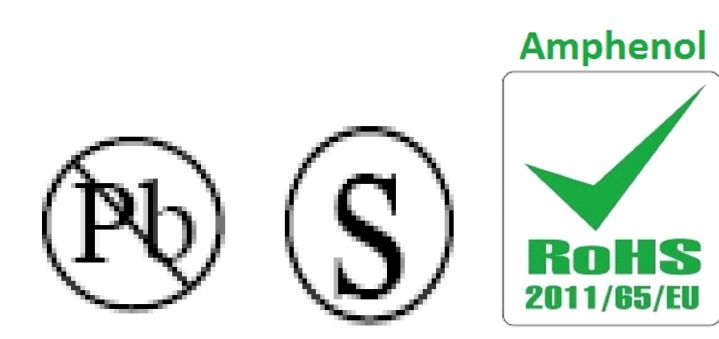
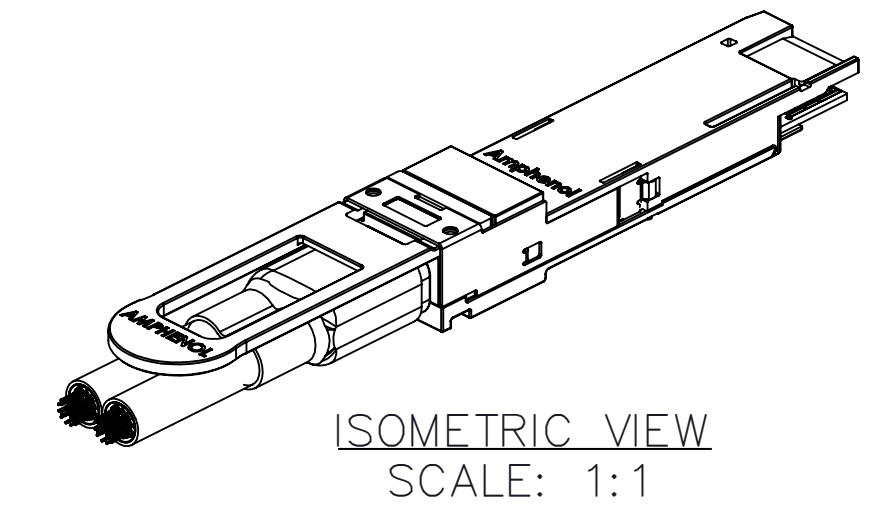
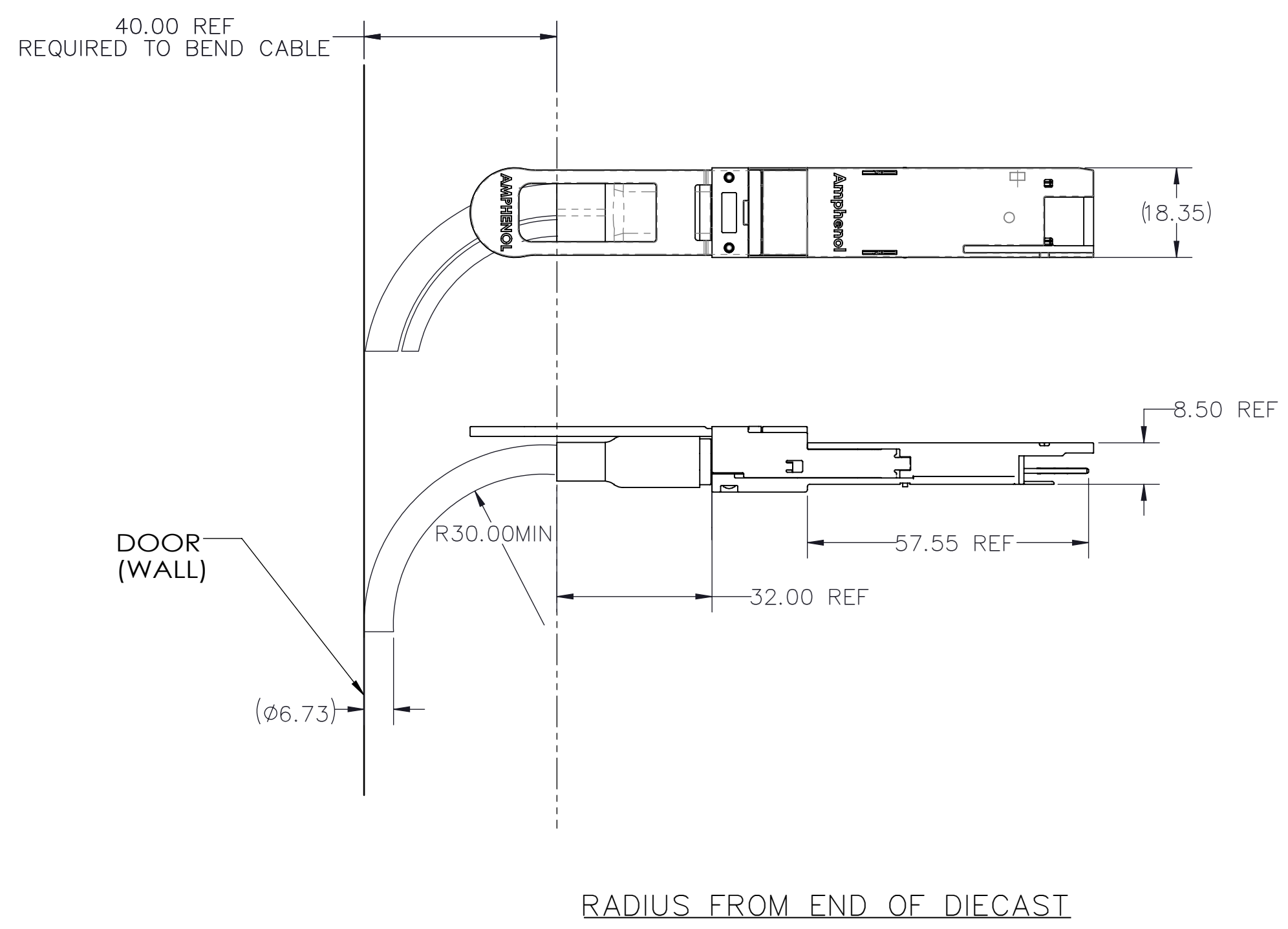

TOLERANCES	DWN 08/11/2017	HCL	<b>Amphenol AHSP</b> A Division of Amphenol Corporation 200 Innovative Way, Suite 201, Nashua, N.H. 03062 (603) 879-3000
0.0 ± 0.1	CHK 10/19/2017	M.HUSSAIN	
0.00 ± 0.08	APVD 10/19/2017	M.HUSSAIN	
0.000 ± -			
ANGLES ± 1.0°			TITLE CABLE ASSY, QSFP-DD PASSIVE, 100Ω, DUAL-ENTRY 30 AWG
UNLESS OTHERWISE SPECIFIED DIMENSIONS ARE IN MM			PART NO. SEE TABLE 1 REV N/A
CUSTOMER USE DRAWING			DRAWING NO. C-NDYYYYF-0099 REV N
SIZE D	SCALE 2:1	SHEET 1 of 2	

REVISIONS						
ZONE	REV.	ECN NUMBER	DESCRIPTION	BY	DATE	APPROVED
			SEE SHEET 1			

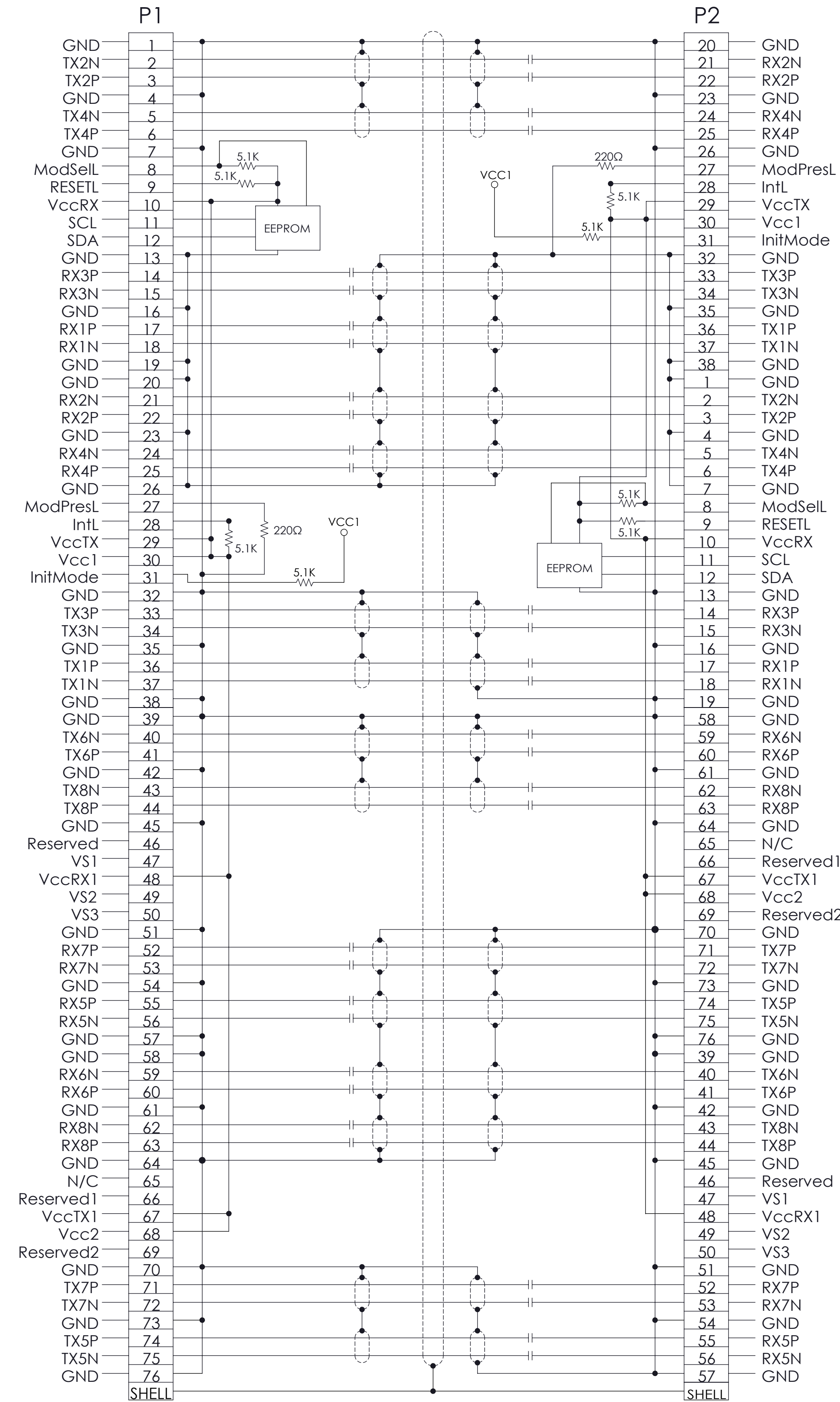

NOTE: DC BLOCKING CAP VALUE IS 100nF

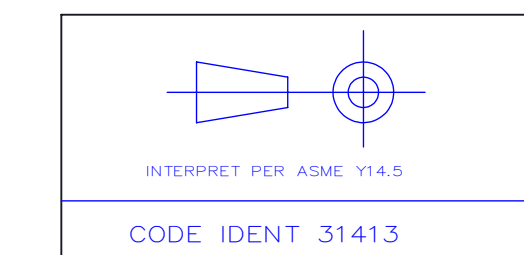

TOLERANCES		DWN	08/11/2017	<b>Amphenol AHSP</b>		
0.0	± 0.1	CHK	10/19/2017	A Division of Amphenol Corporation		
0.00	± 0.08	M.HUSSAIN		200 Innovative Way, Suite 201, Nashua, N.H. 03062 (603) 879-3000		
0.000	± -	APVD	10/19/2017	TITLE		
ANGLES	± 1.0°	M.HUSSAIN		CABLE ASSY, QSFP-DD PASSIVE, 100Ω, DUAL-ENTRY 30 AWG		
UNLESS OTHERWISE SPECIFIED DIMENSIONS ARE IN MM						
PART NO.				SEE TABLE 1	REV	N/A
DRAWING NO.				C-NDYYYY-0099	REV	N
SIZE	D	SCALE	1:1	SHEET 2 of 2		