

# Product data sheet

Specifications



## Logic controller, Modicon M241, 24 IO relay Ethernet CAN master

TM241CEC24R

### Main

Range of product	Modicon M241
Product or component type	Logic controller
[Us] rated supply voltage	100...240 V AC
Discrete input number	14, discrete input 8 fast input conforming to IEC 61131-2 Type 1
Discrete output type	Transistor Relay
Discrete output number	6 relay 4 transistor 4 fast output
Discrete output voltage	5...125 V DC for relay output 5...250 V AC for relay output 24 V DC for transistor output
Discrete output current	2 A for relay output (Q4...Q9) 0.1 A for fast output (PTO mode) (TR0...TR3) 0.5 A for transistor output (TR0...TR3)

### Complementary

Discrete I/O number	24
Maximum number of I/O expansion module	7 (local I/O-Architecture) 14 (remote I/O-Architecture)
Supply voltage limits	85...264 V
Network frequency	50/60 Hz
Discrete input logic	Sink or source
Discrete input voltage	24 V
Discrete input voltage type	DC
Voltage state 1 guaranteed	$\geq 15$ V for input
Voltage state 0 guaranteed	$\leq 5$ V for input
Discrete input current	5 mA for input
Input impedance	4.7 kOhm for input
Response time	50 $\mu$ s turn-on, I0...I13 terminal(s) for input
Configurable filtering time	1 $\mu$ s for fast input
Discrete output logic	Positive logic (source)
Output voltage limits	125 V DC relay output 30 V DC transistor output 277 V AC relay output

<b>Maximum output frequency</b>	1 kHz for transistor output 20 kHz for fast output (PWM mode) 100 kHz for fast output (PLS mode)
<b>Accuracy</b>	+/- 0.1 % at 0.02...0.1 kHz for fast output +/- 1 % at 0.1...1 kHz for fast output
<b>Protection type</b>	Short-circuit protection for transistor output Short-circuit and overload protection with automatic reset for transistor output Reverse polarity protection for transistor output Without protection for relay output
<b>Reset time</b>	10 ms automatic reset output 12 s automatic reset fast output
<b>Memory capacity</b>	8 MB for program 64 MB for system memory RAM
<b>Data backed up</b>	128 MB built-in flash memory for backup of user programs
<b>Data storage equipment</b>	<= 16 GB SD card (optional)
<b>Battery type</b>	BR2032 lithium non-rechargeable, battery life: 4 year(s)
<b>Backup time</b>	2 years at 25 °C
<b>Execution time for 1 KInstruction</b>	0.3 ms for event and periodic task 0.7 ms for other instruction
<b>Application structure</b>	4 cyclic master tasks 8 external event tasks 8 event tasks 3 cyclic master tasks + 1 freewheeling task
<b>Realtime clock</b>	With
<b>Clock drift</b>	<= 60 s/month at 25 °C
<b>Positioning functions</b>	PTO function 4 channel(s) (positioning frequency: 100 kHz)
<b>Counting input number</b>	4 fast input (HSC mode) at 200 kHz 14 standard input at 1 kHz
<b>Control signal type</b>	A/B at 100 kHz for fast input (HSC mode) Pulse/direction at 200 kHz for fast input (HSC mode) Single phase at 200 kHz for fast input (HSC mode)
<b>Integrated connection type</b>	Non isolated serial link serial 1 with RJ45 connector and RS232/RS485 interface Non isolated serial link serial 2 with removable screw terminal block connector and RS485 interface USB port with mini B USB 2.0 connector Ethernet with RJ45 connector CANopen J1939 with male SUB-D 9 connector
<b>Supply</b>	(serial 1)serial link supply: 5 V, <200 mA
<b>Transmission rate</b>	1.2...115.2 kbit/s (115.2 kbit/s by default) for bus length of 15 m for RS485 1.2...115.2 kbit/s (115.2 kbit/s by default) for bus length of 3 m for RS232 480 Mbit/s for bus length of 3 m for USB 10/100 Mbit/s for Ethernet 1000 kbit/s for bus length of 20 m for CANopen 800 kbit/s for bus length of 40 m for CANopen 500 kbit/s for bus length of 100 m for CANopen 250 kbit/s for bus length of 250 m for CANopen 125 kbit/s for bus length of 500 m for CANopen 50 kbit/s for bus length of 1000 m for CANopen 20 kbit/s for bus length of 2500 m for CANopen
<b>Communication port protocol</b>	Non isolated serial link: Modbus master/slave
<b>Port Ethernet</b>	10BASE-T/100BASE-TX - 1 port(s) copper cable
<b>Ethernet services</b>	SNMP client/server Modbus TCP slave device Modbus TCP server Modbus TCP client IEC VAR ACCESS FTP client/server SQL client DHCP client Ethernet/IP adapter Send and receive email from the controller based on TCP/UDP library Web server (WebVisu & XWeb system) OPC UA server DNS client
<b>Local signalling</b>	1 LED (green) for PWR 1 LED (green) for RUN 1 LED (red) for module error (ERR) 1 LED (red) for I/O error (I/O) 1 LED (green) for SD card access (SD)

1 LED (red) for BAT  
 1 LED (green) for SL1  
 1 LED (green) for SL2  
 1 LED (red) for bus fault on TM4 (TM4)  
 1 LED per channel (green) for I/O state  
 1 LED (green) for Ethernet port activity  
 1 LED (green) for CANopen run  
 1 LED (green) for CANopen error

<b>Electrical connection</b>	removable screw terminal block for inputs and outputs (pitch 5.08 mm) removable screw terminal block for connecting the 24 V DC power supply (pitch 5.08 mm)
<b>Maximum cable distance between devices</b>	Unshielded cable: <50 m for input Shielded cable: <10 m for fast input Unshielded cable: <50 m for output Shielded cable: <3 m for fast output
<b>Insulation</b>	Between supply and internal logic at 500 V AC Non-insulated between supply and ground
<b>Marking</b>	CE
<b>Sensor power supply</b>	24 V DC at 400 mA supplied by the controller
<b>Surge withstand</b>	2 kV power lines (AC) common mode conforming to EN/IEC 61000-4-5 2 kV relay output common mode conforming to EN/IEC 61000-4-5 1 kV shielded cable common mode conforming to EN/IEC 61000-4-5 1 kV power lines (AC) differential mode conforming to EN/IEC 61000-4-5 1 kV relay output differential mode conforming to EN/IEC 61000-4-5 1 kV input common mode conforming to EN/IEC 61000-4-5 1 kV transistor output common mode conforming to EN/IEC 61000-4-5
<b>Web services</b>	Web server
<b>Maximum number of connections</b>	16 Ethernet/IP device 8 Modbus server
<b>CANopen feature profile</b>	DR 303-1 DS 301 V4.02
<b>Number of slave</b>	63 CANopen:
<b>Mounting support</b>	Top hat type TH35-15 rail conforming to IEC 60715 Top hat type TH35-7.5 rail conforming to IEC 60715 plate or panel with fixing kit
<b>Height</b>	90 mm
<b>Depth</b>	95 mm
<b>Width</b>	150 mm
<b>Net weight</b>	0.53 kg

## Environment

<b>Standards</b>	ANSI/ISA 12-12-01 CSA C22.2 No 142 CSA C22.2 No 213 EN/IEC 61131-2:2007 Marine specification (LR, ABS, DNV, GL) UL 1604 UL 508
<b>Product certifications</b>	CSA IACS E10 RCM cULus
<b>Resistance to electrostatic discharge</b>	8 kV in air conforming to EN/IEC 61000-4-2 4 kV on contact conforming to EN/IEC 61000-4-2
<b>Resistance to electromagnetic fields</b>	10 V/m 80 MHz...1 GHz conforming to EN/IEC 61000-4-3 3 V/m 1.4 GHz...2 GHz conforming to EN/IEC 61000-4-3 1 V/m 2 GHz...3 GHz conforming to EN/IEC 61000-4-3
<b>Resistance to fast transients</b>	2 kV (power lines) conforming to EN/IEC 61000-4-4 2 kV (relay output) conforming to EN/IEC 61000-4-4 1 kV (Ethernet line) conforming to EN/IEC 61000-4-4 1 kV (serial link) conforming to EN/IEC 61000-4-4 1 kV (input) conforming to EN/IEC 61000-4-4 1 kV (transistor output) conforming to EN/IEC 61000-4-4
<b>Resistance to conducted disturbances</b>	10 V 0.15...80 MHz conforming to EN/IEC 61000-4-6 3 V 0.1...80 MHz conforming to Marine specification (LR, ABS, DNV, GL) 10 V spot frequency (2, 3, 4, 6.2, 8.2, 12.6, 16.5, 18.8, 22, 25 MHz) conforming to Marine specification (LR, ABS, DNV, GL)

<b>Electromagnetic emission</b>	Conducted emissions - test level: 120...69 dB $\mu$ V/m QP ( power lines) at 10...150 kHz conforming to EN/IEC 55011 Conducted emissions - test level: 63 dB $\mu$ V/m QP ( power lines) at 1.5...30 MHz conforming to EN/IEC 55011 Conducted emissions - test level: 79 dB $\mu$ V/m QP/66 dB $\mu$ V/m AV ( power lines) at 0.15...0.5 MHz conforming to EN/IEC 55011 Conducted emissions - test level: 73 dB $\mu$ V/m QP/60 dB $\mu$ V/m AV ( power lines) at 0.5...300 MHz conforming to EN/IEC 55011 Radiated emissions - test level: 40 dB $\mu$ V/m QP class A ( 10 m) at 30...230 MHz conforming to EN/IEC 55011 Conducted emissions - test level: 79...63 dB $\mu$ V/m QP ( power lines) at 150...1500 kHz conforming to EN/IEC 55011 Radiated emissions - test level: 47 dB $\mu$ V/m QP class A ( 10 m) at 230...1000 MHz conforming to EN/IEC 55011
<b>Immunity to microbreaks</b>	10 ms
<b>Ambient air temperature for operation</b>	-10...50 °C (vertical installation) -10...55 °C (horizontal installation)
<b>Ambient air temperature for storage</b>	-25...70 °C
<b>Relative humidity</b>	10...95 %, without condensation (in operation) 10...95 %, without condensation (in storage)
<b>IP degree of protection</b>	IP20 with protective cover in place
<b>Pollution degree</b>	2
<b>Operating altitude</b>	0...2000 m
<b>Storage altitude</b>	0...3000 m
<b>Vibration resistance</b>	3.5 mm at 5...8.4 Hz on symmetrical rail 3 gn at 8.4...150 Hz on symmetrical rail 3.5 mm at 5...8.4 Hz on panel mounting 3 gn at 8.4...150 Hz on panel mounting
<b>Shock resistance</b>	15 gn for 11 ms

## Packing Units

<b>Unit Type of Package 1</b>	PCE
<b>Number of Units in Package 1</b>	1
<b>Package 1 Height</b>	11.335 cm
<b>Package 1 Width</b>	13.188 cm
<b>Package 1 Length</b>	18.727 cm
<b>Package 1 Weight</b>	780.0 g
<b>Unit Type of Package 2</b>	S03
<b>Number of Units in Package 2</b>	8
<b>Package 2 Height</b>	30 cm
<b>Package 2 Width</b>	30 cm
<b>Package 2 Length</b>	40 cm
<b>Package 2 Weight</b>	7.06 kg
<b>Unit Type of Package 3</b>	P06
<b>Number of Units in Package 3</b>	64
<b>Package 3 Height</b>	75.0 cm
<b>Package 3 Width</b>	40.0 cm
<b>Package 3 Length</b>	80.0 cm
<b>Package 3 Weight</b>	64.8 kg

## Offer Sustainability

<b>Sustainable offer status</b>	Green Premium product
---------------------------------	-----------------------

<b>REACH Regulation</b>	<a href="#">REACH Declaration</a>
<b>EU RoHS Directive</b>	Pro-active compliance (Product out of EU RoHS legal scope) <a href="#">EU RoHS Declaration</a>
<b>Mercury free</b>	Yes
<b>China RoHS Regulation</b>	<a href="#">China RoHS declaration</a>
<b>RoHS exemption information</b>	Yes
<b>Environmental Disclosure</b>	<a href="#">Product Environmental Profile</a>
<b>Circularity Profile</b>	<a href="#">End of Life Information</a>
<b>WEEE</b>	The product must be disposed on European Union markets following specific waste collection and never end up in rubbish bins
<b>PVC free</b>	Yes
<b>California proposition 65</b>	WARNING: This product can expose you to chemicals including: Lead and lead compounds, which is known to the State of California to cause cancer and birth defects or other reproductive harm. For more information go to <a href="http://www.P65Warnings.ca.gov">www.P65Warnings.ca.gov</a>

## Dimensions

---

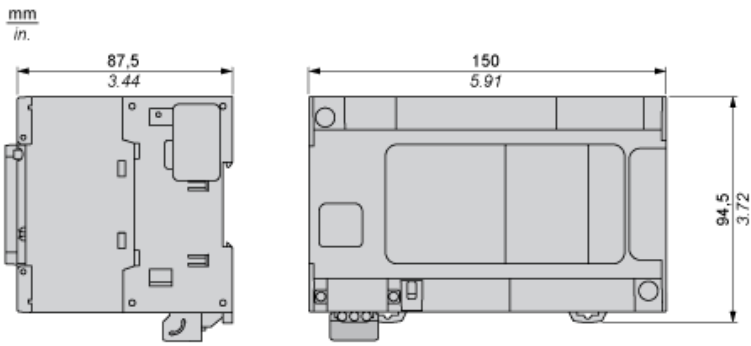

**Clearance**

---

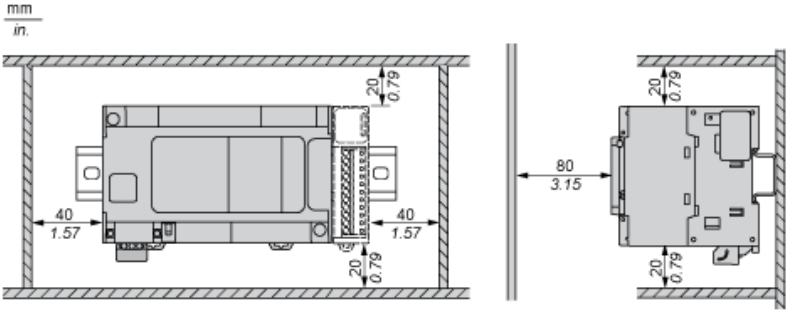

**Mounting Position**

---

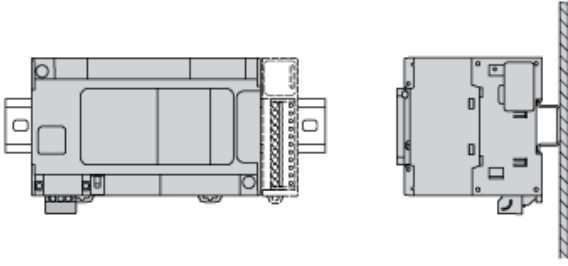

**Acceptable Mounting**

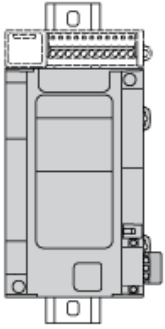

**NOTE:** Expansion modules must be mounted above the logic controller.

**Incorrect Mounting**

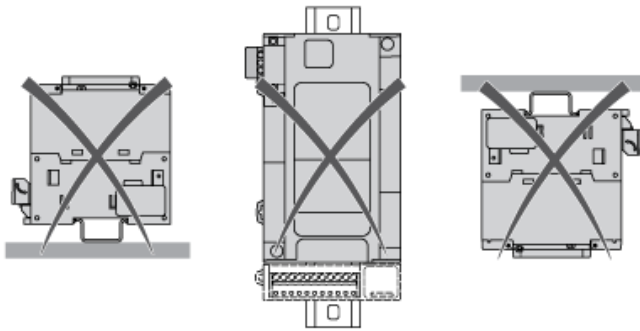



Direct Mounting On a Panel Surface

---

Mounting Hole Layout

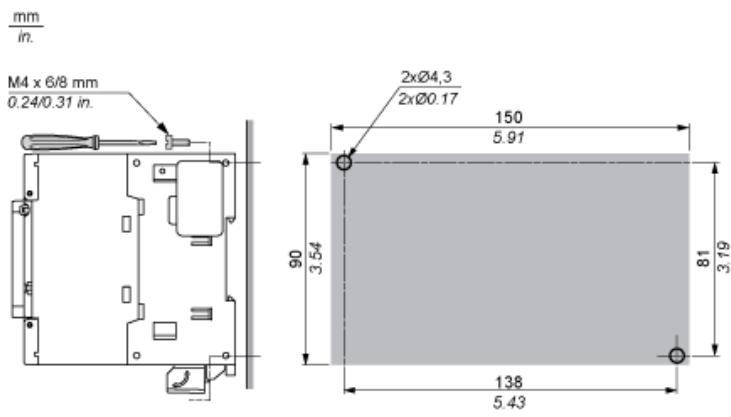

**Digital Inputs**

**Wiring Diagram (Positive Logic)**

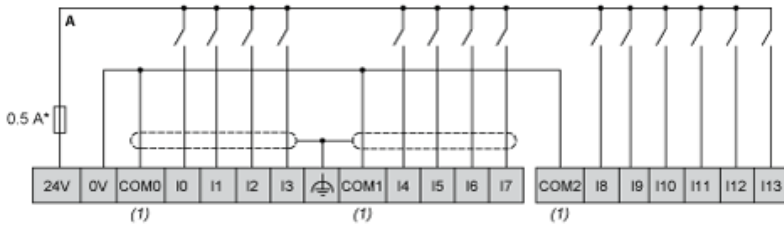

- (\*) : Type T fuse
- (1) : The COM0, COM1 and COM2 terminals are not connected internally.

**Wiring Diagram (Negative Logic)**

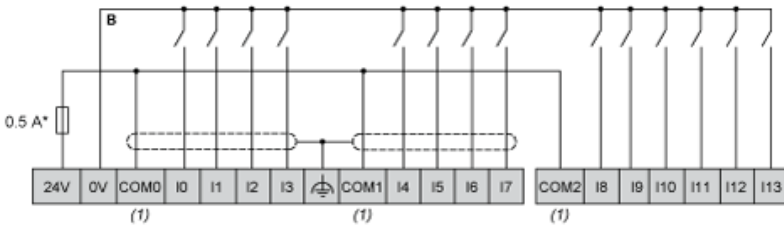

- (\*) : Type T fuse
- (1) : The COM0, COM1 and COM2 terminals are not connected internally.

Fast Transistor Outputs

---

Wiring Diagram

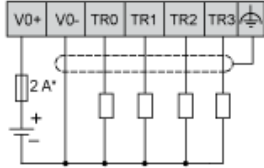

(\*) : 2 A fast-blow fuse

**Relay Outputs**

**Wiring Diagram**

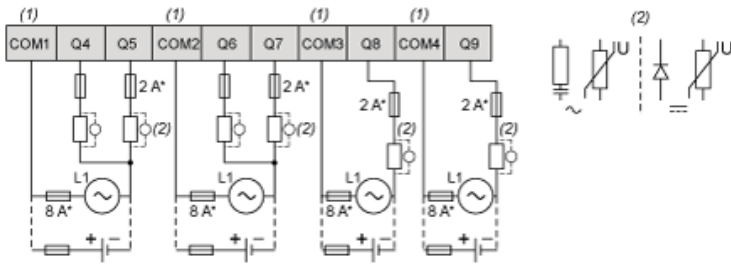

(\*) : Type T fuse

(1) : The terminals COM1 to COM4 are not connected internally.

(2) : To improve the life time of the contacts, and to protect from potential inductive load damage, you must connect a free wheeling diode in parallel

**USB Mini-B Connection**

---

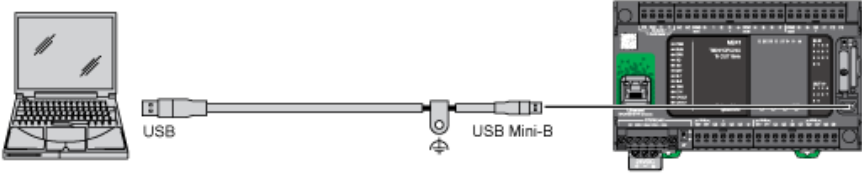

**Ethernet Connection to a PC**

---

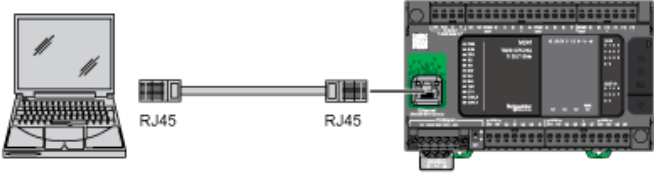

**CANopen Connection**

**Wiring Diagram**

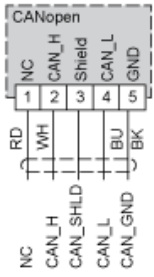

Pin	Signal	Description	Marking	Color of Cable
1	Not used	Reserved	NC	red
2	CAN_H	CAN_H bus line (dominant high)	CAN_H	white
3	CAN_SHLD	Optional CAN shield	Shield	-
4	CAN_L	CAN_L bus line (dominant low)	CAN_L	blue
5	CAN_GND	CAN Ground	GND	black

**Recommended replacement(s)**