

Series NSX	SIZE 16 REAR RELEASE, REAR REMOVABLE CRIMP SOCKET CONTACT	Issue: Oct. 26, 2020	Page 1/1
---------------	---	-------------------------	-------------

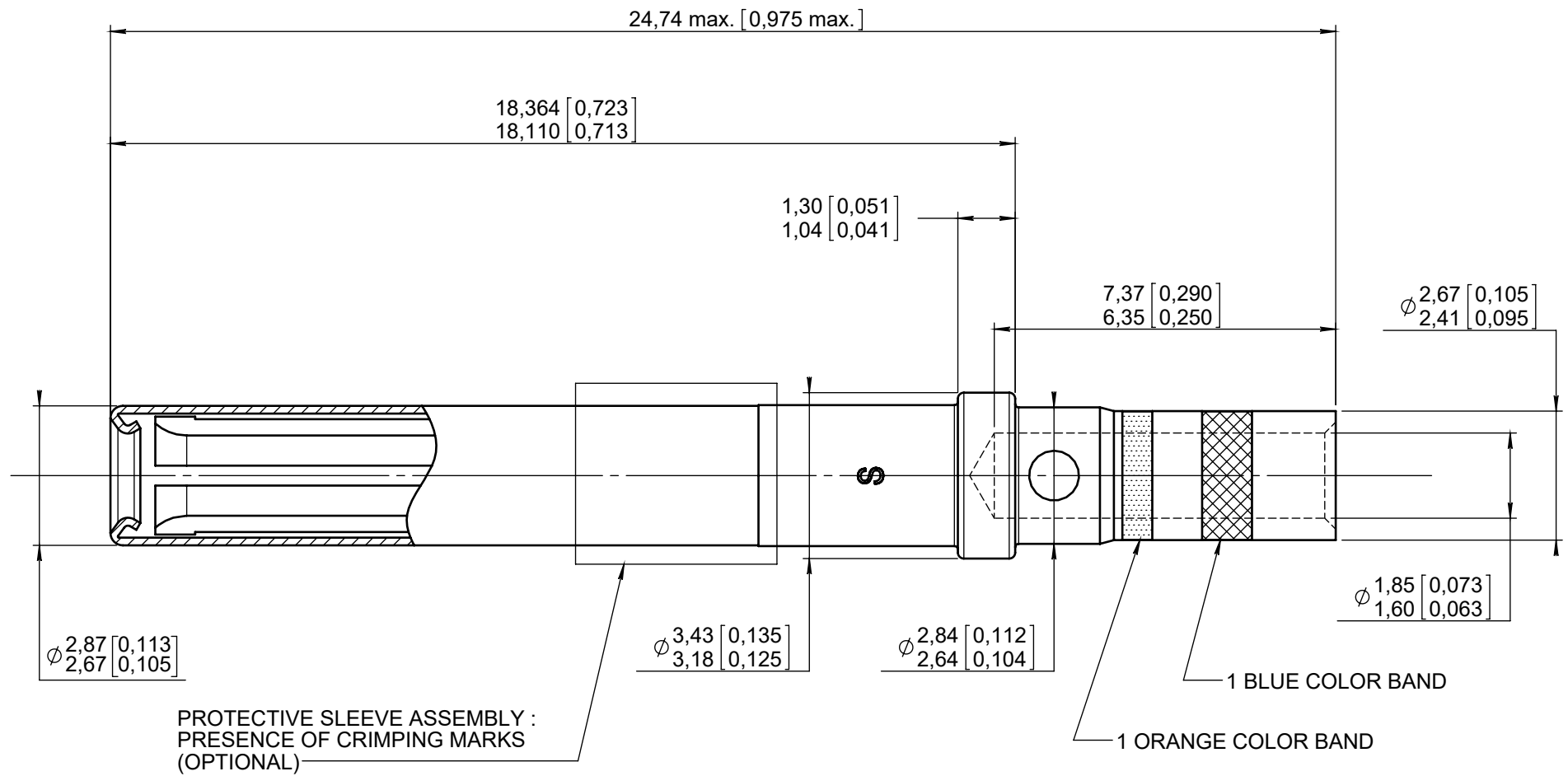

MATERIALS :

CONTACT BODY : BERYLLIUM COPPER PER ASTM B 196
 PROTECTIVE SLEEVE : STAINLESS STEEL

FINISH :

CONTACT BODY : PLATING .00005 INCH OF GOLD PER SAE AMS-2422 OVER NICKEL PER SAE AMS-QQ-N-290
 CONTACT PROTECTIVE SLEEVE : PASSIVATED

WIRES ACCOMODATED : AWG 16-18-20

WIRE OUTSIDE DIAMETER : 0,102 Maxi
 STRIP LENGTH : 0,236

TOOLING :

CRIMPING TOOL : M22520/1-01 RADIALL 282 291
 SELECTOR POSITION : 6 FOR AWG 16
 5 FOR AWG 18
 4 FOR AWG 20
 POSITIONER : M22520/1-02 RADIALL 282 972
 INSERTION AND EXTRACTION TOOL : M81969/1-03 RADIALL 282 546

DIMENSIONS : inch

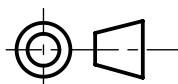

CREATION	Oct. 26, 20	Added note about protective sleeve assembly	BRANJONNEAU	LEGENDRE
	Jan. 26, 2018	Added dimensions in millimeters (mm)	Lopez C.	Legendre T.
PEN: /	Mar. 08, 12	Material updated	Moutault	Dupuis
	Feb.15,11	Added "REAR RELEASE, REAR REMOVABLE"	Moutault	Brochet
NOM: FALETTI	OCT 22 07	Crimping tool Radiall 282 291 was 202 291	Valgresy	BROCHET
	Sept. 20, 07	Corrected "Wire outside diameter" : .130-->.102	Legendre T.	Macari JP.
DATE: April 25, 1983	Apr. 11, 96	Redrawn	Valgresy	/
APPR.: /	Issue	Revisions	Name	Approved

Confidential information not to be disclosed to third parties without Radiall approval. This information is given as an indication. In the continual goal to improve our products, we reserve the right to make any modifications judged necessary.

4112_9311