

# STG-MTN 1,5-2,5 - Crimp contact



3190506

<https://www.phoenixcontact.com/in/products/3190506>

Please be informed that the data shown in this PDF document is generated from our Online Catalog. Please find the complete data in the user documentation. Our General Terms of Use for Downloads are valid.



Module socket contact, inserted in the PCC or HCC plug housing after crimping the conductor, for 1.5 mm<sup>2</sup> ... 2.5 mm<sup>2</sup> conductors

## Commercial Data

Item number	3190506
Packing unit	100 pc
Minimum order quantity	100 pc
Sales Key	AAC
Product Key	AACCEG
Catalog Page	Page 294 (C-1-2019)
GTIN	4017918093372
Weight per Piece (including packing)	0.469 g
Weight per Piece (excluding packing)	0.462 g
Customs tariff number	85366990
Country of origin	PL

# STG-MTN 1,5-2,5 - Crimp contact



3190506

<https://www.phoenixcontact.com/in/products/3190506>

## Technical Data

### Product properties

Product type	Crimp contact
Product family	MSTBC-MT
Pitch	0 mm

### Dimensions

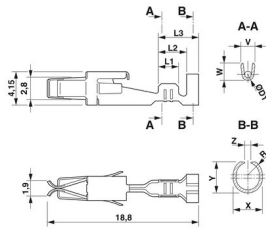
Dimensional drawing	
Pitch	0 mm

### Material specifications

Contact surface	Tin Sn
Contact surface material	Tin

# STG-MTN 1,5-2,5 - Crimp contact

3190506

<https://www.phoenixcontact.com/in/products/3190506>



## Drawings

Dimensional drawing

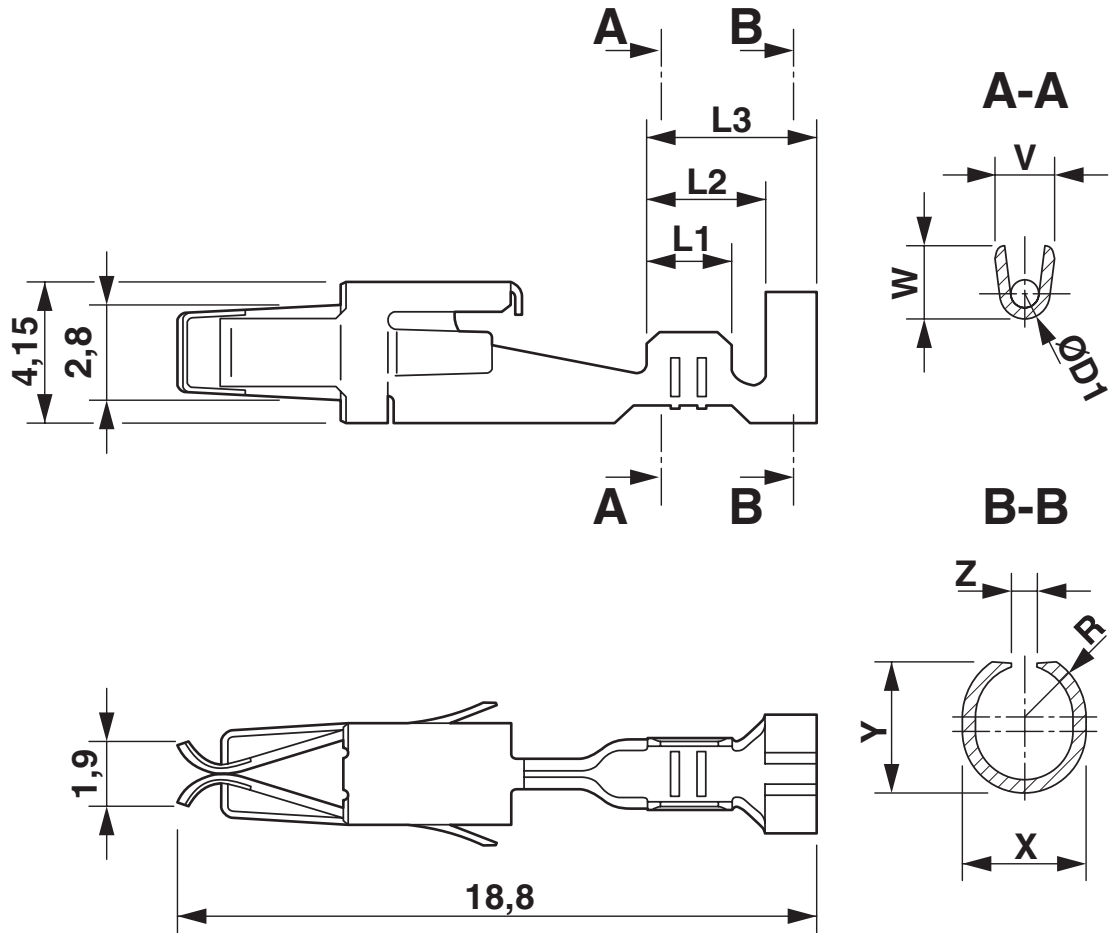

# STG-MTN 1,5-2,5 - Crimp contact



3190506

<https://www.phoenixcontact.com/in/products/3190506>

Diagram

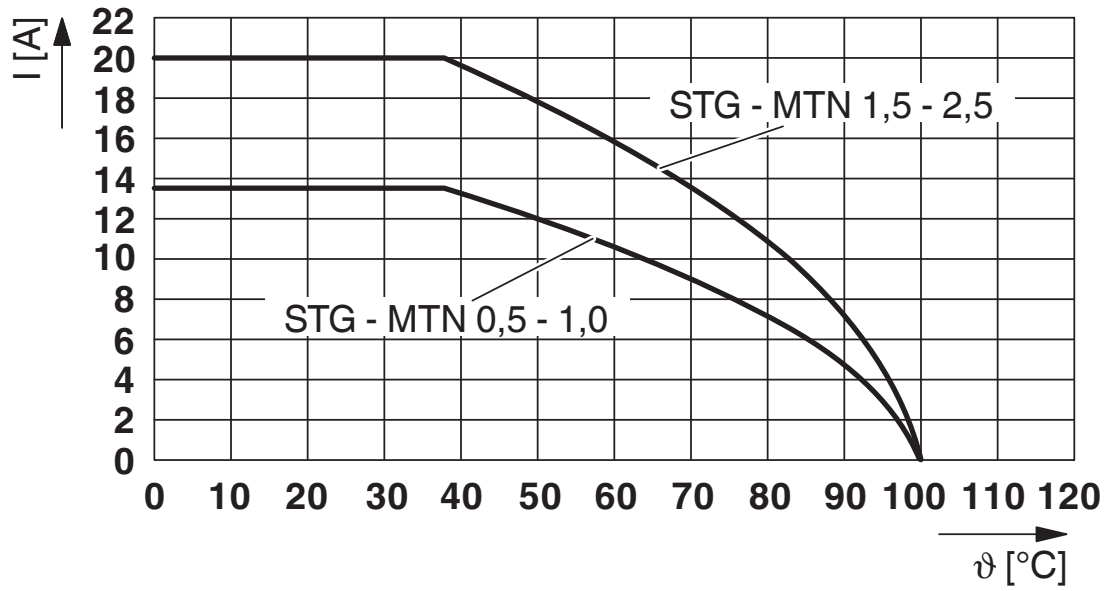

# STG-MTN 1,5-2,5 - Crimp contact

3190506

<https://www.phoenixcontact.com/in/products/3190506>



## Approvals



**EAC**

Approval ID: RU C-DE.BL08.B.00511

# STG-MTN 1,5-2,5 - Crimp contact



3190506

<https://www.phoenixcontact.com/in/products/3190506>

## Classifications

### ECLASS

ECLASS-11.0	27469090
ECLASS-13.0	27469090
ECLASS-13.0	27469090
ECLASS-13.0	27469090

### ETIM

ETIM 8.0	EC002848
----------	----------

### UNSPSC

UNSPSC 21.0	39121400
-------------	----------

# STG-MTN 1,5-2,5 - Crimp contact



3190506

<https://www.phoenixcontact.com/in/products/3190506>

## Environmental Product Compliance

China RoHS	Environmentally friendly use period: unlimited = EFUP-e
	No hazardous substances above threshold values

# STG-MTN 1,5-2,5 - Crimp contact

3190506

<https://www.phoenixcontact.com/in/products/3190506>



## Accessories

### CRIMPFOX MT 2,5 - Crimping pliers

1204038

<https://www.phoenixcontact.com/in/products/1204038>



Crimping pliers, for crimping conductors to the module female contacts STG-MTN, crimp range: 0.5-2.5 mm<sup>2</sup>, AWG: 20-14

---

### CEC 2,5 - Filler plugs

3062757

<https://www.phoenixcontact.com/in/products/3062757>



Cover for conductor shaft, 10-pos., for spring cage terminal blocks (ST) and terminal blocks with push-in technology (PT) with a width of 5.2 mm



# STG-MTN 1,5-2,5 - Crimp contact

3190506

<https://www.phoenixcontact.com/in/products/3190506>



## WST 2,5 - Warning cover

3030941

<https://www.phoenixcontact.com/in/products/3030941>



Warning cover, 5-pos., for terminal width: 5.2 mm

---

Phoenix Contact 2023 © - all rights reserved

<https://www.phoenixcontact.com>

PHOENIX CONTACT (I) Pvt. Ltd.

A-58/2, Okhla Industrial Area, Phase - II, New Delhi-110 020

+91.1275.71420

[info@phoenixcontact.co.in](mailto:info@phoenixcontact.co.in)