

Series  
MMC

SZE 16 CRIMP SOCKET CONTACT  
FOR AWG 20, 22 AND 24 CABLES

Issue:  
Feb. 22, 2022

Page  
1/1

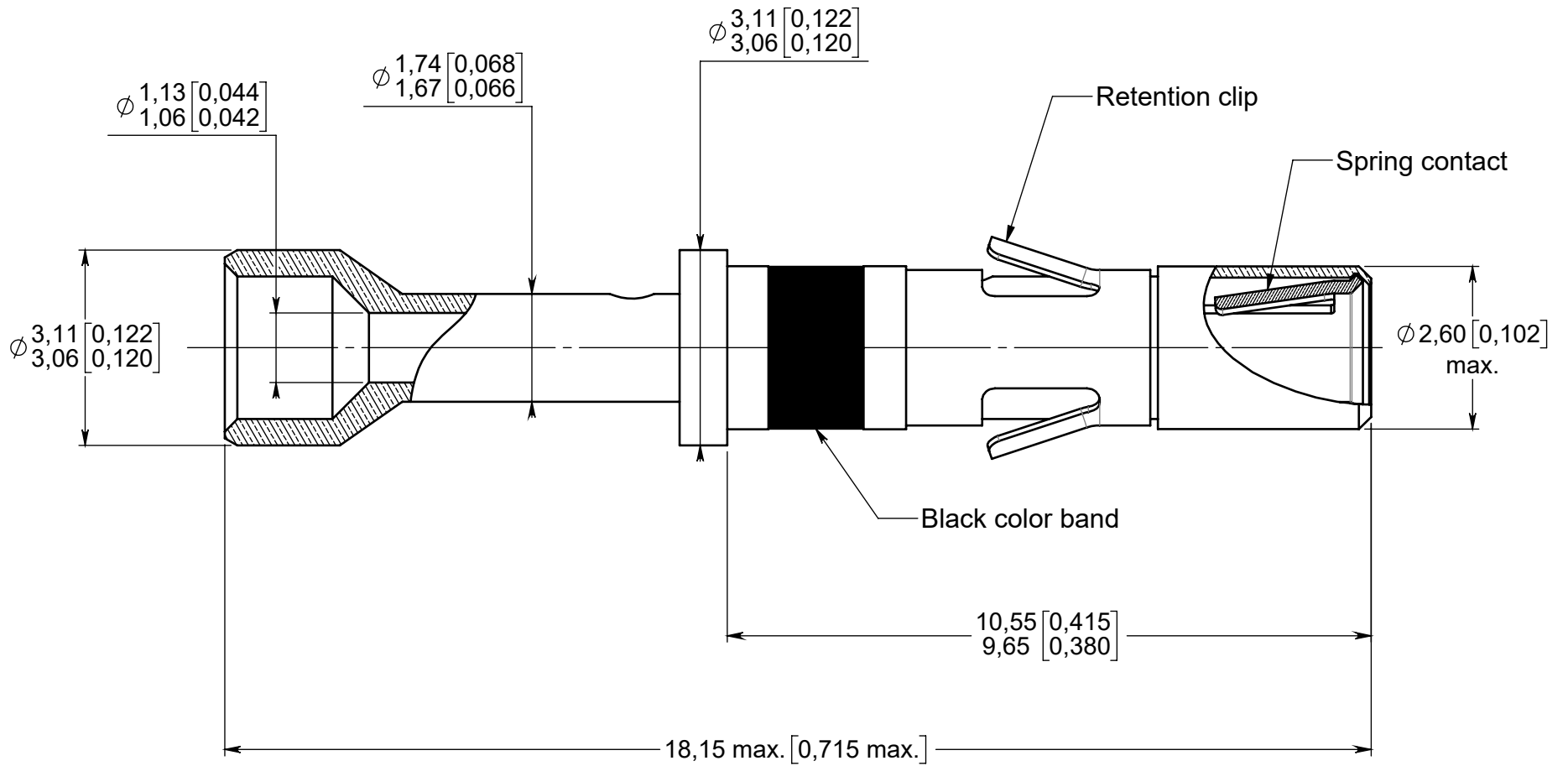

**MATERIALS AND FINISHES:**

- Contact body : Copper alloy, gold over nickel plated
- Retention clip: Copper alloy, nickel plated
- Spring contact : Copper alloy, gold over nickel plated.

**ESTIMATED WEIGHT:** 0,41 Gr. [ .0145 ounces].

**WIRING INSTRUCTIONS:**

- Cable stripping length: 5 mm [ .197]
- Crimping tool: M22520/1.01 - RADIALL P/N 282 291
- Positioner: 282 976  
Position 4 for AWG 20 cable, position 3 for AWG 22 cable, position 2 for AWG 24 cable.
- Extraction tool: 282920

**DIMENSIONS :** mm (inch are given for information only)

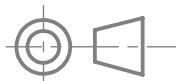

<b>CREATION</b>				
<b>PEN:</b> N/A				
<b>NOM:</b> MONTIER A.	Feb. 22, 22	2,60 max was 2,59/2,54.	L.Garcia	H.Perrin
<b>DATE:</b> Jun. 25, 2014	Aug. 09, 2016	Cable stripping length and estimated weight in ounces added.	Perrin H.	Branjonneau V.
<b>APPR.:</b> PERRIN H.	Issue	Revisions	Name	Approved

This document contains proprietary information and such information shall not be disclosed to any third party for any purpose whatsoever or used for manufacturing purposes without prior written agreement from RADIALL. This information is given as an indication. In the continual goal to improve our products, we reserve the right to make any modifications judged necessary.

4112\_9311