

51536-58		REVISIONS	
LTR	DESCRIPTION	DATE	APPVD
C	(CL 11) REDRAWN SAME SIZE SEE ECN: 84215		
D	(CL 11) SEE ECN 91328	9/1/69	Hobson

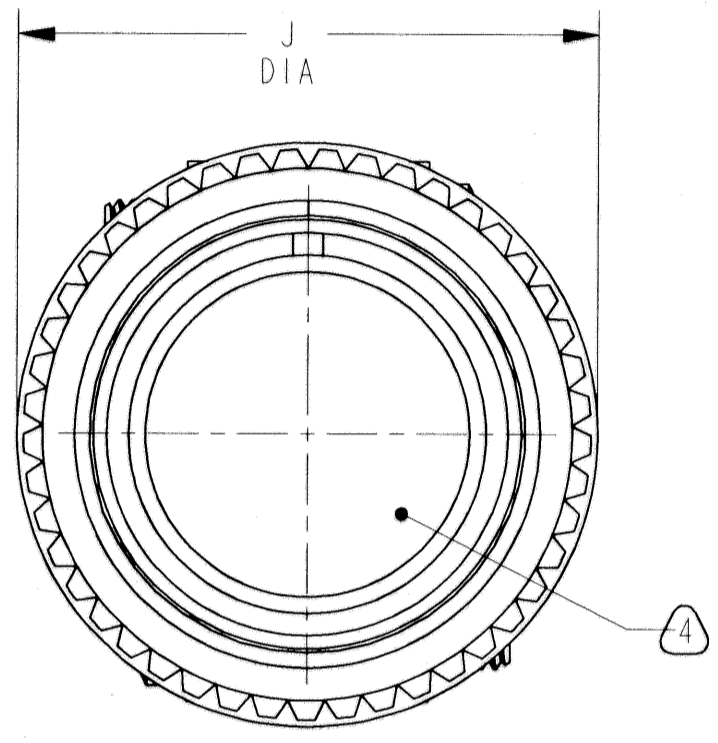

6  
 .062  
 STAMP MS NUMBER, "AMPHENOL"  
 AND DATE CODE (9-3895)  
 OPPOSITE KEYWAY PER 9-2811  
 IN APPROXIMATE POSITION SHOWN  
 EXAMPLE:  
 JMS3106F-18-1P AMPHENOL 9829

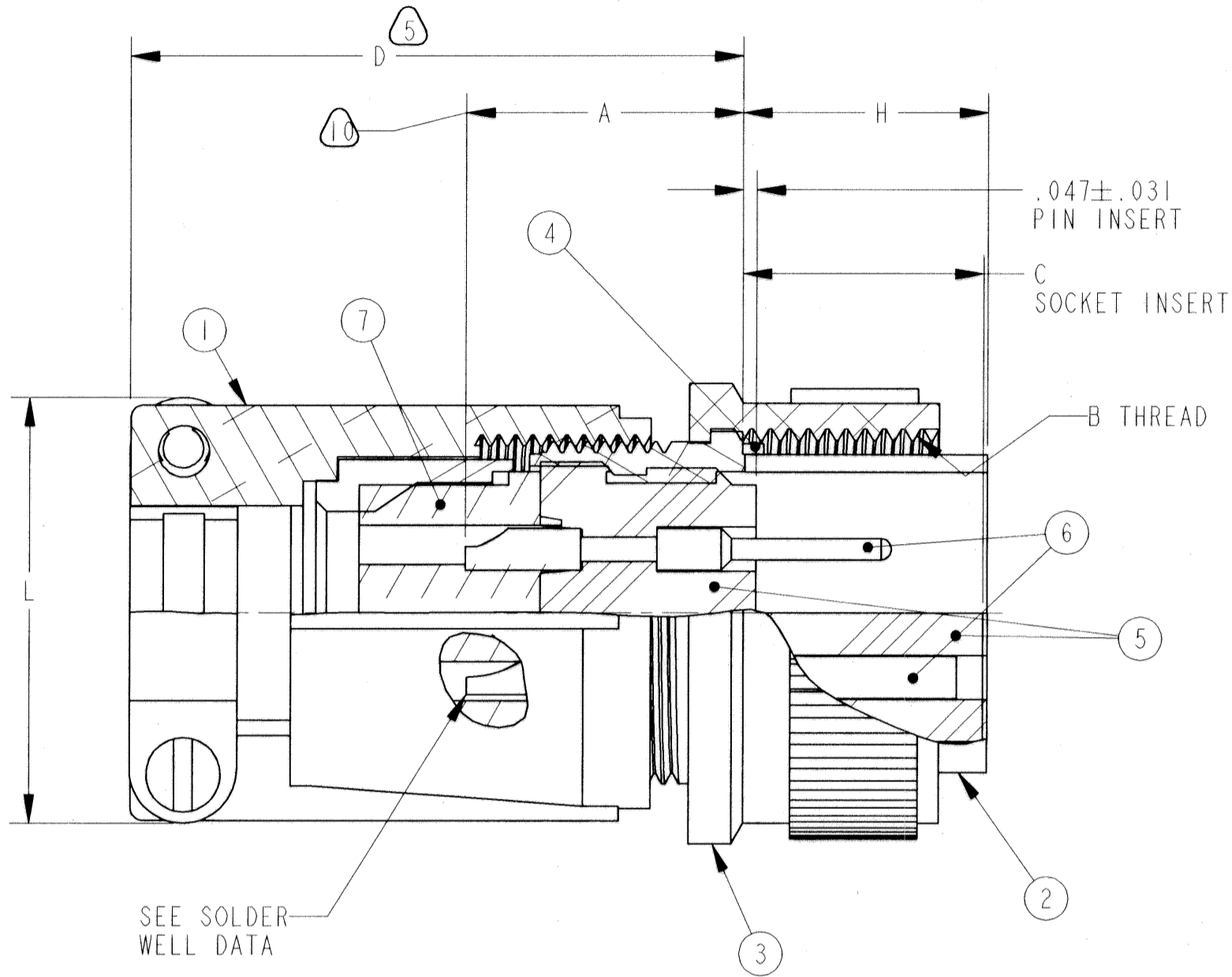
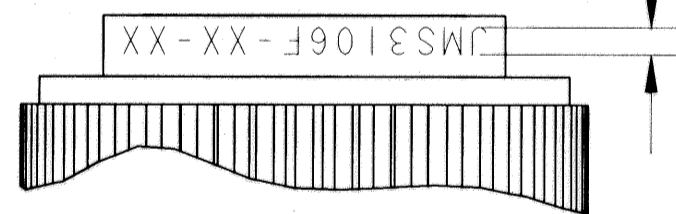

CONTACT DATA(WHERE APPLICABLE)	
THERMOCOUPLE	
MATERIAL	IDENTIFICATION
CHROMEL	WHITE
ALUMEL	GREEN
IRON	BLACK
CONSTANTAN	YELLOW

INSERT ARRANGEMENTS CONTAINING THERMOCOUPLE CONTACTS MUST HAVE SUCH CONTACTS ASSEMBLED INTO THE INSERT IN PROPER LOCATIONS AS SPECIFIED BY APPLICABLE DRAWINGS MIL-STD-1651

CONTACT SIZE	STANDARD SOLDER WELL DATA					THERMOCOUPLE	
	0	4	8	12	16	12	16
WELL DIA	.469 +.005 -.003	.332 +.005 -.003	.209 +.004 -.002	.116 +.004 -.002	.078 +.004 -.002	.125 +.004 -.002	.094 +.004 -.002
WELL DEPTH	+.031 -.000	.625	.625	.500	.375	.250	.188

POS	QTY	PART NUMBER	DESCRIPTION	NOTE
7	1	SEE COLUMN	GROMMET	
6	AR	SEE NOTE	CONTACTS	
5	1	SEE COLUMN	INSERT	
4	1	10-035957-XXI	GASKET	
3	1	SEE COLUMN	COUPLING	
2	1	SEE COLUMN	SHELL	
1	1	SEE COLUMN	BACKSHELL KIT	

SEE SHEET 2.

**NOTES:**

THE USE OF THIS DOCUMENT IS UNLIMITED. HOWEVER, DOCUMENTS REFERENCED HEREON MAY CONTAIN LIMITED RIGHTS DATA.

STAMPING DATA	NEXT ASSEMBLY
N/A	N/A

UNLESS OTHERWISE SPECIFIED	SPECIFICATIONS
LINEAR DIMENSIONS ARE IN INCHES TOLERANCES: .XXXX = ±.0005 .XXX = ±.010 .XX = ±.03 .X = ±.1 ANGLES = ±2° OTHER STANDARDS PER 9-3800 AND DOD-D-1000 THIRD ANGLE PROJECTION	MATERIAL SPEC. N/A PROCESS SPEC. TEST 9-3106-5 ASSY 9-2437, 9-2811 9-3103-1, 9-3895
	APPROVALS PREPARED: WHITNEY 11-4-69 CHECKED: MENDEOLA 11/18/69 APPROVED: R.W. TYLER 11-6-69 APPROVED: WMHARRISON 11-19-69

PARTS LIST			
AMPHENOL CORPORATION			
SIDNEY, N.Y. 13838			
CONNECTOR, ELECTRICAL PLUG, TYPE 3106F			
SIZE	FSCM NO.	DOCUMENT NO.	REV.
C	77820	10-474608/650	D
SCALE: NONE		REF: 10-329860/879	SHEET 1 OF 2

ASSEMBLY NUMBER	MS NUMBER	INSERT	GROMMET	SHELL	COUPLING NUT	BACKSHELL KIT	A ±.045	B THREAD CLASS 2B (PLATED)	C +.047 -.000	D MAX	H MAX	J DIA MAX
10-474608-( )	3106F-8S-( )	NOT AVAILABLE										
10-474610-( )	3106F-10S-( )	NOT AVAILABLE										
10-474611-( )	3106F-10SL-( )	10-074811-( )	10-060711-( )	10-37266-011	SHELL ASSY	10-584182-113	.562	.6250-24 UNEF	.531	2.129	.531	.946
10-474612-( )	3106F-12S-( )	10-074812-( )	10-060712-( )	10-37266-012	10-37265-12	10-584182-113	.562	.7500-20 UNEF	.531	2.129	.531	.995
10-474613-( )	3106F-12-( )	10-074813-( )	10-060713-( )	10-37266-013	10-37265-13	10-584182-113	.812	.7500-20 UNEF	.719	2.129	.719	.995
10-474614-( )	3106F-14S-( )	10-074814-( )	10-060714-( )	10-37266-014	10-37265-14	10-584185-143	.562	.8750-20 UNEF	.531	2.201	.531	1.123
10-474615-( )	3106F-14-( )	10-074815-( )	10-060715-( )	10-37266-015	10-37265-15	10-584185-143	.812	.8750-20 UNEF	.719	2.524	.719	1.123
10-474616-( )	3106F-16S-( )	10-074816-( )	10-060716-( )	10-37266-016	10-37265-16	10-584187-163	.562	1.0000-20 UNEF	.531	2.201	.531	1.250
10-474617-( )	3106F-16-( )	10-074817-( )	10-060717-( )	10-37266-017	10-37265-17	10-584188-173	.812	1.0000-20 UNEF	.719	2.524	.719	1.250
10-474618-( )	3106F-18-( )	10-074818-( )	10-060718-( )	10-37266-018	10-37265-18	10-584189-183	.812	1.1250-18 UNEF	.719	2.596	.719	1.333
10-474620-( )	3106F-20-( )	10-074820-( )	10-060720-( )	10-37266-020	10-37265-20	10-584190-203	.812	1.2500-18 UNEF	.719	2.654	.719	1.461
10-474622-( )	3106F-22-( )	10-074822-( )	10-060722-( )	10-37266-022	10-37265-22	10-584191-223	.812	1.3750-18 UNEF	.719	2.654	.719	1.588
10-474624-( )	3106F-24-( )	10-074824-( )	10-060724-( )	10-37266-024	10-37265-24	10-584192-243	.812	1.5000-18 UNEF	.719	2.885	.719	1.715
10-474628-( )	3106F-28-( )	10-074828-( )	10-060728-( )	10-37266-028	10-37265-28	10-584193-283	.812	1.7500-18 UNS	.719	2.885	.719	1.968
10-474632-( )	3106F-32-( )	10-074832-( )	10-060732-( )	10-37266-032	10-37265-32	10-584194-323	.812	2.0000-18 UNS	.719	2.943	.719	2.209
10-474636-( )	3106F-36-( )	10-074836-( )	10-060736-( )	10-37266-036	10-37265-36	10-584195-363	.812	2.2500-16 UN	.719	2.943	.719	2.463
10-474640-( )	3106F-40-( )	10-074840-( )	10-060740-( )	10-37266-040	10-37265-40	10-584196-403	.812	2.5000-16 UN	.719	3.068	.719	2.718
10-474641/50	NOT AVAILABLE											

7

- INDICATED THERMOCOUPLE CONTACT DATA IS APPLICABLE ONLY TO 10-474617-13P/S, 10-474618-15PS (AND THEIR ALTERNATE ARRANGEMENTS) WHICH ARE THE ONLY THERMOCOUPLE ARRANGEMENTS AVAILABLE IN THIS SERIES.
- DELETED
- ALL UNUSED GROMMET HOLES MUST BE FILLED WITH APPROPRIATE SIZE SEALING PLUGS.
- FOR CONTACT SIZE, SPACING AND SERVICE RATING SEE MIL-STD-1651.
- DIMENSION INDICATES FINAL INSTALLATION. FOR STORAGE AND SHIPPING, PARTS MAY BE UNASSEMBLED.
- SEE WORK ORDER FOR PERMISSIBLE ADDITIONAL OR ALTERNATE STAMPING.
- TO COMPLETE ASSEMBLY NUMBER AND MS NUMBER, ADD APPLICABLE INSERT ARRANGEMENT SUFFIX TO BASE NUMBERS LISTED ABOVE. (FOR ALTERNATE ARRANGEMENTS, REFER TO 9-2437).
- ALL LOCKWIRE HOLES ARE .045 DIAMETER MINIMUM.
- SEE SEPARATE PARTS LIST FOR COMPONENT PART NUMBERS AND QUANTITIES.
- INCREASE "A" DIMENSION BY .312 FOR SIZE "0" CONTACT ONLY.

- INSERTS AND CONTACTS ARE REMOVABLE.
- FOR MATING RECEPTACLE ASSEMBLIES, SEE DRAWING 10-474008 THROUGH 10-474050 AND OTHERS.
- PACKAGE PER PRODUCTION PROCESS SHEET.
- SHIP CONNECTOR WITH SEALING PLUGS UNASSEMBLED.
- THE UNITS ILLUSTRATED MEET THE MATERIAL & FINISH REQUIREMENTS OF MIL-C-5015.
- SOME INSERTS AND GROMMETS ARE TOOLED UNDER A +50 PART NUMBER. CONSULT PARTS LIST FOR VERIFICATION.

NOTES:

THE USE OF THIS DOCUMENT IS UNLIMITED. HOWEVER, DOCUMENTS REFERENCED HEREON MAY CONTAIN LIMITED RIGHTS DATA.

SIZE <b>C</b>	FSCM NO. <b>77820</b>	DOCUMENT NO. <b>10-474608/650</b>	REV. <b>D</b>
SCALE: NONE		REF: 10-329860/879	SHEET 2 OF 2

2 OF 2

10-474608/650

DOC NO

A

TAB.