

PAGE 1/3	ISSUE 06-12-19N	SERIES SMA	PART NUMBER R125076000
----------	-----------------	------------	------------------------

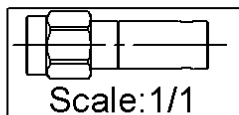

All dimensions are in mm. Tolerances according ISO 2768 m-H

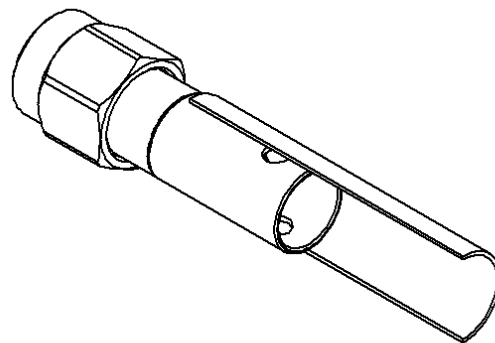
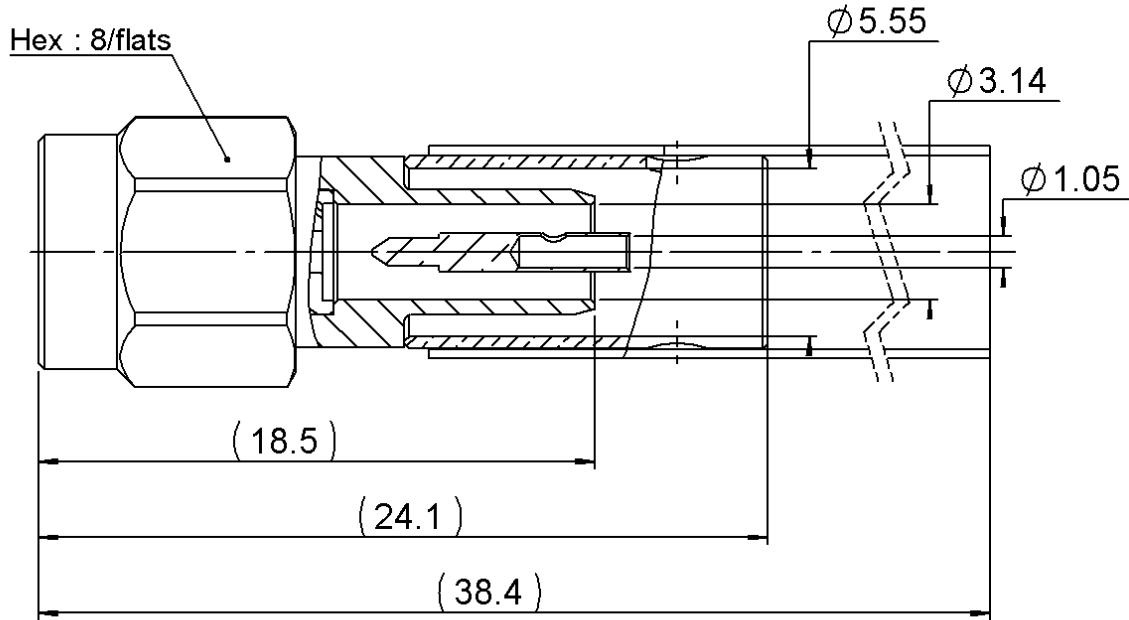
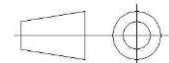

COMPONENTS	MATERIALS	PLATING (µm)
Body	<b>STAINLESS STEEL</b>	<b>GOLD OVER NICKEL</b>
Center contact	<b>BRASS.</b>	<b>GOLD OVER NICKEL</b>
Outer contact	-	-
Insulator	<b>PTFE</b>	
Gasket	<b>SILICONE RUBBER</b>	
Others parts	<b>STAINLESS STEEL</b>	<b>GOLD OVER NICKEL</b>
-	-	-
-	-	-

PAGE <b>2/3</b>	ISSUE <b>06-12-19N</b>	SERIES <b>SMA</b>	PART NUMBER <b>R125076000</b>
-----------------	------------------------	-------------------	-------------------------------

### PACKAGING

Standard	Unit	Other
<b>100</b>	<b>Contact us</b>	<b>Contact us</b>

### ELECTRICAL CHARACTERISTICS

Impedance	<b>50</b>	$\Omega$
Frequency	<b>0-12.4</b>	GHz
VSWR	<b>1.15 + 0,0100</b>	x F(GHz) Maxi
Insertion loss	<b>0.06</b>	$\sqrt{F}$ (GHz) dB Maxi
RF leakage	- ( <b>60</b> )	- F(GHz)) dB Maxi
Voltage rating	<b>335</b>	Veff Maxi
Dielectric withstanding voltage	<b>1000</b>	Veff mini
Insulation resistance	<b>5000</b>	M $\Omega$ mini

### MECHANICAL CHARACTERISTICS

Center contact retention		
Axial force – Mating End	<b>NA</b>	N mini
Axial force – Opposite end	<b>NA</b>	N mini
Torque	<b>NA</b>	N.cm mini
Recommended torque		
Mating	<b>100</b>	N.cm
Panel nut	<b>NA</b>	N.cm
Clamp nut	<b>NA</b>	N.cm
A/F clamp nut	<b>0,0000</b>	mm
Mating life	<b>500</b>	Cycles mini
Nominal Weight (Add +15% for max weight)	<b>3,8300</b>	g

### ENVIRONMENTAL

Operating temperature	<b>-65/+165</b>	$^{\circ}\text{C}$
Hermetic seal	<b>NA</b>	Atm.cm3/s
Panel leakage	<b>NA</b>	

### SPECIFICATION

**AMD BA LEA A 00**  
**03 COC 9 MAG-202(13/06/88)**

### CABLE ASSEMBLY

Stripping	a	b	c	d	e	f
mm	<b>3,5</b>	<b>7</b>	<b>13,5</b>	<b>0</b>	<b>10</b>	<b>0</b>

Assembly instruction:

Recommended cable(s)

**RG 223**  
**RG 142 BU**  
**RG 400**  
**KX 23**  
**RG 142 FTX**

Characteristics indicated on this data sheet are those that can be achieved with the highest performance cable. Intrinsic limitations of the cable may diminish the performance of the assembly

Cable retention

- pull off	<b>204</b>	N mini
- torque	<b>NA</b>	N.cm

### TOOLING

Part Number	Description	Hexagon
R282235011	CRIMPING DIES M22520/5-11	5.40
R282293000	CRIMPING TOOL M22520/5-01	-
R282223000	CRIMPING TOOL	5.40

### OTHER CHARACTERISTICS

-

PAGE 3/3	ISSUE 06-12-19N	SERIES SMA	PART NUMBER R125076000
----------	-----------------	------------	------------------------

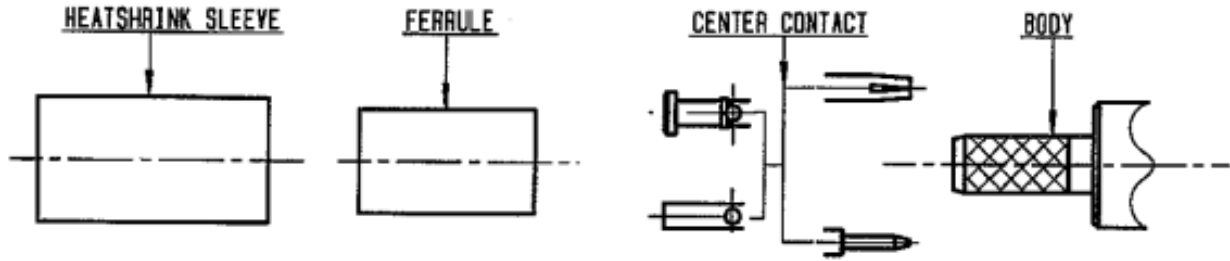

①

Slide ferrule and heatshrink sleeve onto cable .  
Strip the cable .  
-  
-

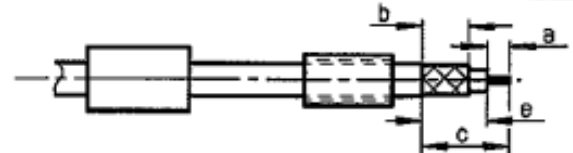

Stripping	a	b	c	d	e
inch	0.138	0.276	0.531	0	0.394
mm	3.5	7	13.5		10

②

Slide center contact on until it bottoms against cable dielectric .  
Solder center contact .  
Clean soldered area .  
-  
-

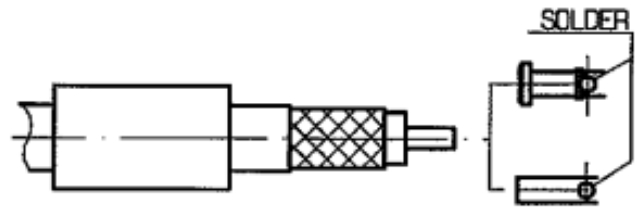

③

Fan the braid .  
Slide cable into body until it bottoms against insulator .  
Slide ferrule over the braid .  
(In direction F)

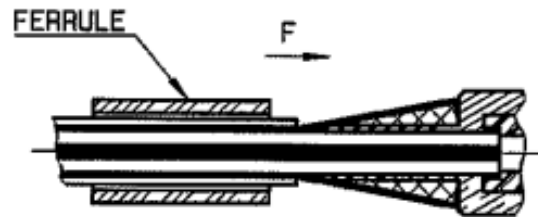

④

Crimp the ferrule with crimping tool R 282 223 000 ( Hex. : 5.41 ) or crimping tool R 282 293 000 ( M22520/5-01 ) + dies R 282 235 011 ( M22520/5-11 )  
Cut the excess of braid if necessary  
Slide sleeve over ferrule and heatshrink in place .  
-  
-

Shrink the heatshrink sleeve

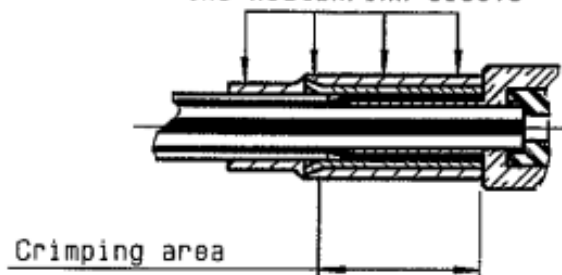

Crimping area