

# Product data sheet

Specifications



## 3"5 color touch controller panel - Dig 8 inputs/8 outputs +Ana 4 In/2 Out

HMISCU6B5

**Product availability : Stock - Normally stocked in distribution facility**

**Price\* : 1,013.69 USD**

### Main

Range of Product	Harmony SCU
Product or Component Type	Small touch HMI controller
Display size	3.5 inch
Display type	Backlit LED colour TFT LCD
Touch panel	Analogue
Device presentation	Complete product

### Complementary

Display Resolution	320 x 240 pixels QVGA
Backlight lifespan	50000 hours 65000 colours
Brightness	16 levels via touch panel
View angle horiz x vert	60° left 60° right 40° top 60° bottom
Character font	Chinese (simplified Chinese) ASCII Taiwanese (traditional Chinese) Korean Japanese (ANK, Kanji)
Supply	External source
[Us] rated supply voltage	24 V 20.4...28.8 V)DC
Immunity to microbreaks	10 ms
Inrush current	30 A
Power Consumption in W	15 W
Local signalling	No indicator
Number of pages	Limited by internal memory capacity
Software Designation	SoMachine
Operating System	Harmony
Processor name	CPU RISC
Processor frequency	333 MHz
Memory description	Flash NAND, 128 MB Internal data storage FRAM, 128 kB

\* Price is "List Price" and may be subject to a trade discount – check with your local distributor or retailer for actual price.

<b>Integrated connection type</b>	1 serial link - RJ45 - RS232/RS485 <= 115.2 kbits/s) 1 Ethernet TCP/IP - RJ45 1 USB 2.0 type mini B 1 USB 2.0 type A CANopen master bus - SUB-D 9
<b>Realtime clock</b>	Built-in
<b>Downloadable protocols</b>	Modbus TCP/IP CANopen Modbus
<b>Fixing mode</b>	By 1 nut Ø 22 mm 1...6 mm thick panel
<b>Enclosure Material</b>	PC/PBT
<b>Shock resistance</b>	147 m/s <sup>2</sup> 11 ms on DIN rail)IEC 60068-2-27 294 m/s <sup>2</sup> 6 ms on panel mounting)IEC 60068-2-27
<b>Vibration resistance</b>	+/- 3.5 mm 5...9 Hz) IEC 60068-2-6 1 gn 9...150 Hz) IEC 60068-2-6
<b>Electromagnetic compatibility</b>	Electrostatic discharge immunity test 8 kV air discharge) IEC 61000-4-2 Electrostatic discharge immunity test 6 kV contact discharge) IEC 61000-4-2 Susceptibility to electromagnetic fields 10 V/m 80 MHz...3 GHz) IEC 61000-4-3 Electrical fast transient/burst immunity test 2 kV power lines) IEC 61000-4-4 Electrical fast transient/burst immunity test 1 kV between analogue I/O and operating voltage) IEC 61000-4-4 Electrical fast transient/burst immunity test 2 kV relay wires) IEC 61000-4-4 Electrical fast transient/burst immunity test 1 kV Ethernet line) IEC 61000-4-4 Electrical fast transient/burst immunity test 1 kV COM line) IEC 61000-4-4 Electrical fast transient/burst immunity test 1 kV CAN line) IEC 61000-4-4 Surge immunity test 2 kV power supply (common mode)) IEC 61000-4-5 Surge immunity test 1 kV power supply (differential mode)) IEC 61000-4-5 Surge immunity test 1 kV common mode digital I/O) IEC 61000-4-5 Surge immunity test 0.5 kV differential mode digital I/O) IEC 61000-4-5 Conducted RF disturbances 10 V 0.15...80 MHz) IEC 61000-4-6 Conducted emission 150 kHz...30 MHz EN 55011 Radiated emission 30 MHz...1 GHz EN 55011
<b>Discrete input number</b>	2 fast input (normal mode) IEC 61131-2 Type 1 6 digital input IEC 61131-2 Type 1
<b>Discrete input voltage</b>	24 V DC sink or source (positive/negative)
<b>Number of common point</b>	1 fast input (HSC mode) 1 digital input
<b>Discrete input current</b>	7.83 mA fast input 5 mA digital
<b>Input impedance</b>	2.81 kOhm 4.7 kOhm
<b>Sensor power supply</b>	15...28.8 V DC >= 15 V >= 5 mA <= 5 V <= 1.5 mA 15...28.8 V DC >= 15 V >= 2.5 mA <= 5 V <= 1 mA
<b>Configurable filtering time</b>	0 ms no filter none) 0.004...0.04 ms bounce filter latch/event and cumulative filter by step Nx0.5ms (64>=N>=2)) 3...12 ms integrator none/run/stop)
<b>Maximum input frequency</b>	100 kHz fast input (encoder mode) A/B 100 kHz fast input single phase 100 kHz fast input pulse/direction
<b>Maximum cable distance between devices</b>	Shielded cable <32.81 ft (10 m) fast input Shielded cable <328.08 ft (100 m) digital input Unshielded cable <164.04 ft (50 m) digital input
<b>Connection pitch</b>	0.14 in (3.5 mm)
<b>Overvoltage protection</b>	With
<b>Isolation between channels and internal logic</b>	500 V DC
<b>Isolation between channels</b>	None
<b>Discrete output number</b>	2 fast output (normal mode) source 6 digital output source
<b>Discrete output voltage</b>	24 V DC 19.2...28.8 V)transistor 24 V DC 5...30 V)relay 220 V AC 100...250 V)relay
<b>Input/Output number</b>	2 fast input FI0...FI1 2 fast output FQ0...FQ1 6 digital input DI0...DI5

6 digital output DQ0...DQ5

<b>Discrete output current</b>	2 A 4 A)5 ms opening contact digital output 2 A 4 A)2 ms closing contact digital output 300 mA2 ms fast output (normal mode) 50 mA2 ms fast output (PWM or PTO mode)
<b>Insulation resistance</b>	> 10 MOhm between the I/O and internal logic > 10 MOhm between power supply and earth
<b>Maximum output frequency</b>	100 kHz fast output (PTO mode) 1 kHz fast output (PWM mode)
<b>Absolute accuracy error</b>	+/- 0.1 % of full scale cyclic ratio 1...99% fast output (PWM or PTO mode) 1 % of full scale cyclic ratio 1...99% fast output (PWM or PTO mode) +/- 5 % of full scale cyclic ratio 10...90% fast output (PWM or PTO mode) +/- 10 % of full scale cyclic ratio 20...80% fast output (PWM or PTO mode) +/- 15 % of full scale cyclic ratio 30...70% fast output (PWM or PTO mode)
<b>Analogue input number</b>	2 analog input 2 RTDs
<b>Analogue input range</b>	0...20 mA/4...20 mA 12 bits 250 Ohm +/- 1 %) -10...+10 V or 0...10 V 12 bits + sign >= 1 MOhm
<b>Analogue input type</b>	RTD - 200...600 °C 16 bitsPt 100/Pt 1000 RTD - 50...200 °C 16 bitsNi 100/Ni 1000 RTD - 200...760 °C 16 bits thermocouple J) RTD - 240...1370 °C 16 bits thermocouple K) RTD 0...1600 °C 16 bits thermocouple R) RTD 200...1800 °C 16 bits thermocouple B) RTD 0...1600 °C 16 bits thermocouple S) RTD - 200...400 °C 16 bits thermocouple T) RTD - 200...900 °C 16 bits thermocouple E) RTD - 200...1300 °C 16 bits thermocouple N)
<b>Analogue output number</b>	2 resistive load 12 bits + sign
<b>Analogue output range</b>	0...20 mA/4...20 mA > 300 Ohm)open-circuit -10...10 V/0...10 V > 2 kOhm)short-circuit
<b>Height</b>	2.95 in (74.95 mm)
<b>Width</b>	5.04 in (128 mm)
<b>Depth</b>	4.02 in (102 mm)
<b>Net Weight</b>	1.21 lb(US) (0.551 kg)

## Environment

<b>Standards</b>	CSA C22.2 No 213 Class I Division 2 EN 61131-2 IEC 61000-6-2 ANSI/ISA 12-12-01 UL 508 FCC Class A
<b>Product Certifications</b>	cULus CSA 22-2 No 142 cUL 1604 Class 1 Division 2 C-tick GOST KCC cULus 508 UKCA UKEX
<b>Marking</b>	CE
<b>Ambient Air Temperature for Operation</b>	32...122 °F (0...50 °C)
<b>Ambient Air Temperature for Storage</b>	-4...140 °F (-20...60 °C)
<b>Relative humidity</b>	5...85 % without condensation
<b>Operating altitude</b>	<= 6561.68 ft (2000 m)
<b>Storage altitude</b>	0.00...32808.40 ft (0...10000 m)
<b>Maximum pressure</b>	800...1114 hPa
<b>IP degree of protection</b>	IP20 IEC 60529 rear panel) IP65 IEC 60529 front panel)
<b>NEMA degree of protection</b>	NEMA 4X front panel

Pollution degree	2 IEC 60664
Environmental characteristic	Corrosive gas free

## Ordering and shipping details

Category	22568-HMI CONTROLLERS
Discount Schedule	MC2
GTIN	3595864175560
Returnability	Yes
Country of origin	CN

## Packing Units

Unit Type of Package 1	PCE
Number of Units in Package 1	1
Package 1 Height	7.24 in (18.4 cm)
Package 1 Width	4.25 in (10.8 cm)
Package 1 Length	10.51 in (26.7 cm)
Package 1 Weight	2.45 lb(US) (1.113 kg)
Unit Type of Package 2	S03
Number of Units in Package 2	4
Package 2 Height	11.81 in (30 cm)
Package 2 Width	11.81 in (30 cm)
Package 2 Length	15.75 in (40 cm)
Package 2 Weight	11.24 lb(US) (5.1 kg)

## Offer Sustainability

Sustainable offer status	Green Premium product
California proposition 65	WARNING: This product can expose you to chemicals including: Lead and lead compounds, which is known to the State of California to cause cancer and birth defects or other reproductive harm. For more information go to <a href="http://www.P65Warnings.ca.gov">www.P65Warnings.ca.gov</a>
REACH Regulation	<a href="#">REACH Declaration</a>
EU RoHS Directive	Pro-active compliance (Product out of EU RoHS legal scope) <a href="#">EU RoHS Declaration</a>
Mercury free	Yes
China RoHS Regulation	<a href="#">China RoHS declaration</a>
RoHS exemption information	<a href="#">Yes</a>
Environmental Disclosure	<a href="#">Product Environmental Profile</a>
Circularity Profile	<a href="#">End of Life Information</a>
WEEE	The product must be disposed on European Union markets following specific waste collection and never end up in rubbish bins.
Upgradeability	Upgradeable through digital modules and upgraded components

## Dimensions

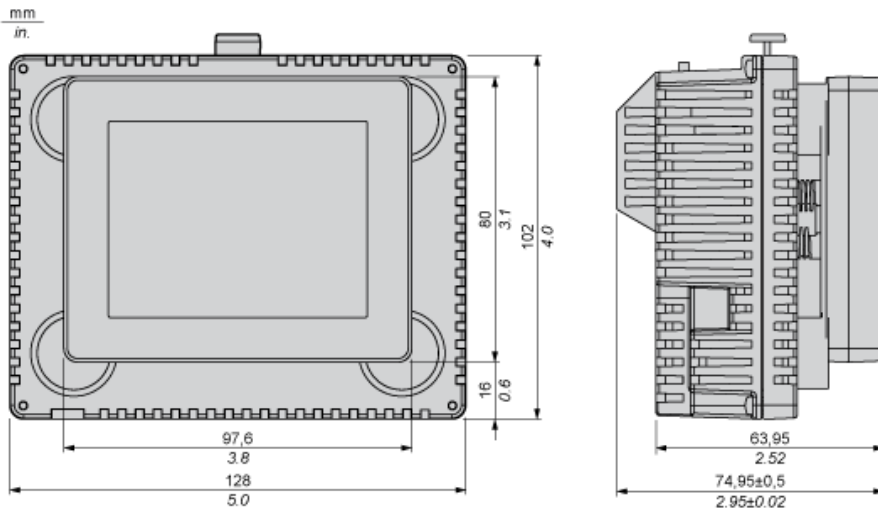

## Recommended Mounting position

---

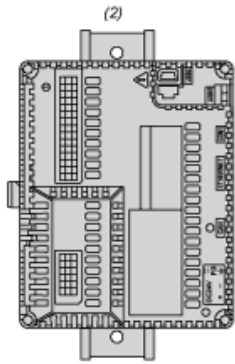
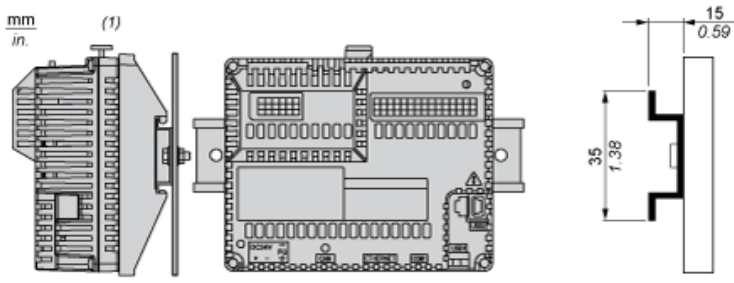

- (1) Horizontal mounting
- (2) Vertical mounting

**No Recommended Mounting Position**

---

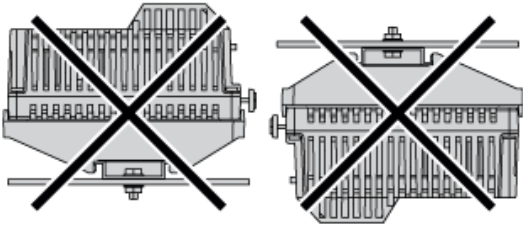

Clearance

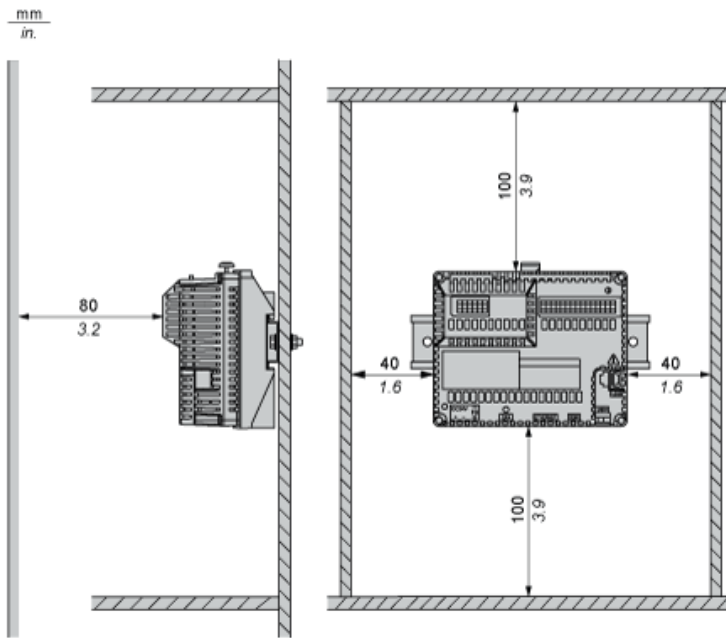

Keep adequate spacing for proper ventilation to maintain an ambient temperature between 0...50 °C (32...122 °F) for horizontal installation and 0...40 °C (32...104 °F) for vertical installation.



**Wiring Diagram**

---

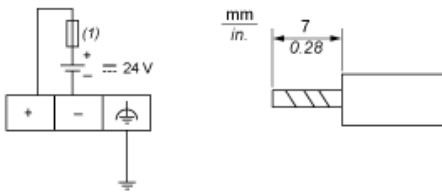

(1) Slow-blow 2A type T fuse

**Wiring Diagram of the Analog Inputs and Analog Outputs**

**Voltage for Analog Inputs**

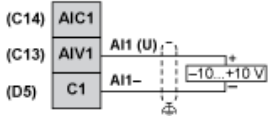
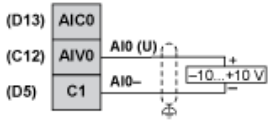

**Current for Analog Inputs**

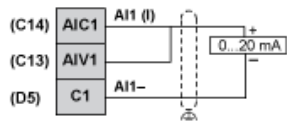
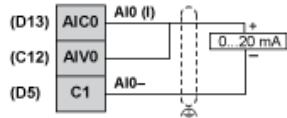

**Voltage and Current for Analog Outputs**

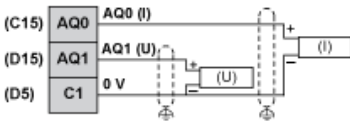

**3 Wiring for Analog Inputs PT100**

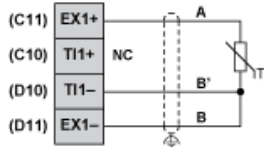
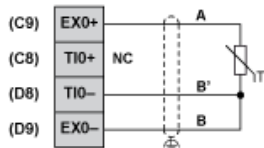

**2 Wiring for Analog Inputs PT100**

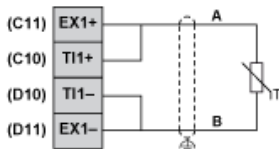
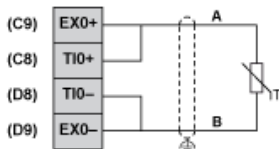

**Thermocouple**

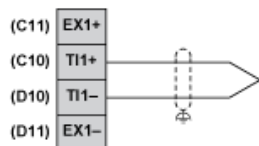
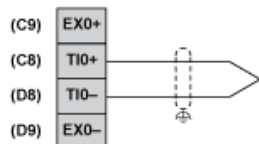

## Wiring Diagram of Digital Inputs

---

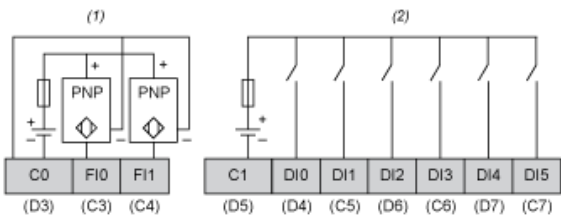

- (1) HSC inputs with pin assignment of terminal blocks C,D.
- (2) Digital inputs with pin assignment of terminal blocks C,D.

**Wiring Diagram of Digital Outputs**

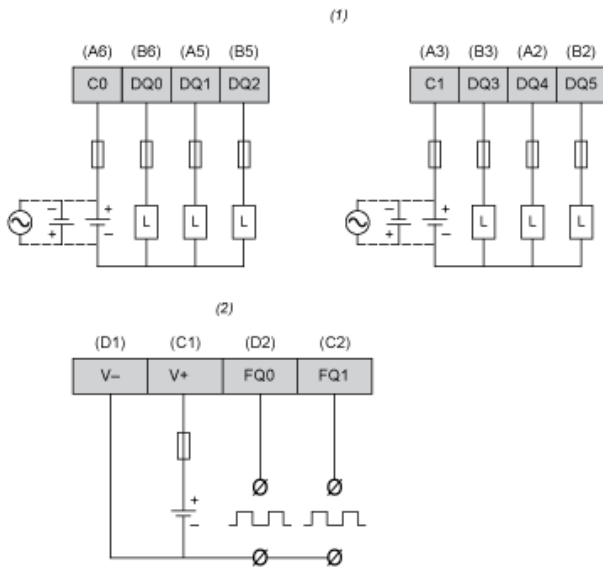

- (1) Digital outputs with pin assignment of terminal blocks A,B.
- (2) PWM outputs with pin assignment of terminal blocks C,D.

**Recommended replacement(s)**