

M55116/3-X

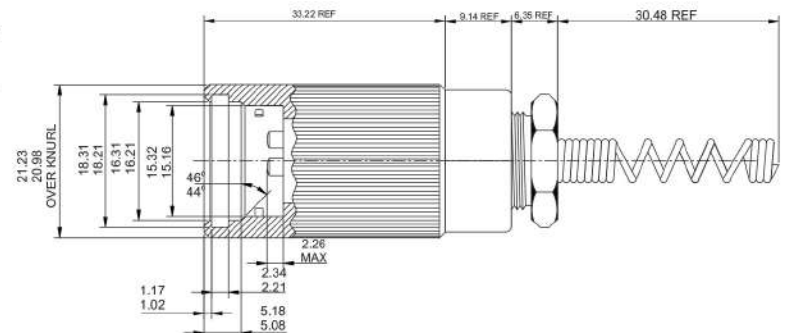
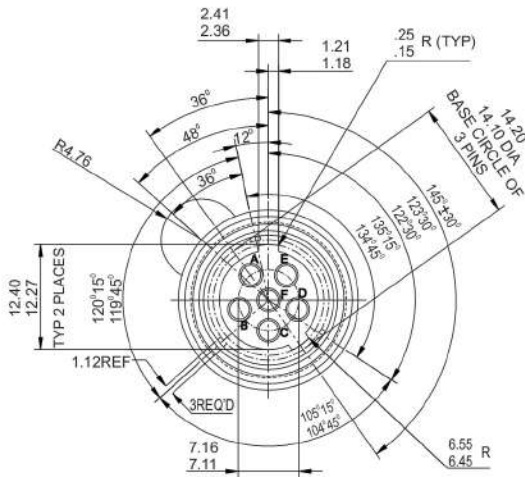

M55116/4-X

Sr No.	Description	MIL Designation	Amphenol Designation
1	5 Pin Audio plug connector with Solder Cup Terminal & wire strain relief	M55116/3-X	164-229-S-X
2	6 Pin Audio plug connector with Solder Cup Terminal & wire strain relief	M55116/4-X	164-229-6S-X

Dash no-X	Cable diameter
-0	N/A
-1	4.19 ± 0.25
-2	5.79 ± 0.25
-3	6.35 ± 0.25
-4	7.36 ± 0.25
-5	8.12 ± 0.25

X Stands for the Cable size accommodation, is identified by a dash number as shown in above table. This number indicates the outside diameter of the cable that the connector will accommodate.